



**NANYANG  
TECHNOLOGICAL  
UNIVERSITY**

School of Mechanical & Aerospace Engineering

Design, Machine, Control, Intelligence



MA4822

# Measurement and Sensing Systems

Xie Ming, PhD (France)

[mmxie@ntu.edu.sg](mailto:mmxie@ntu.edu.sg)

<http://personal.ntu.edu.sg/mmxie>

# Outline

- ▶ Module 1: Foundation of AI Sensors
- ▶ Module 2: Sensors for Electrical Systems
- ▶ Module 3: Sensors for Mechanical Systems
- ▶ Module 4: Sensors for All Environments
- ▶ Module 5: Sensors for All Industries

# Remember your mission as MAE undergraduates ...

- ▶ You are here to grow your knowledge and skills so as to be able to design machines with **controllable behaviors** and hopefully in some **intelligent ways**.

# How to fulfill your mission?

- ▶ To apply learnt knowledge and skills into the implementation of the following universal blueprint underlying all the intelligent machines or systems.

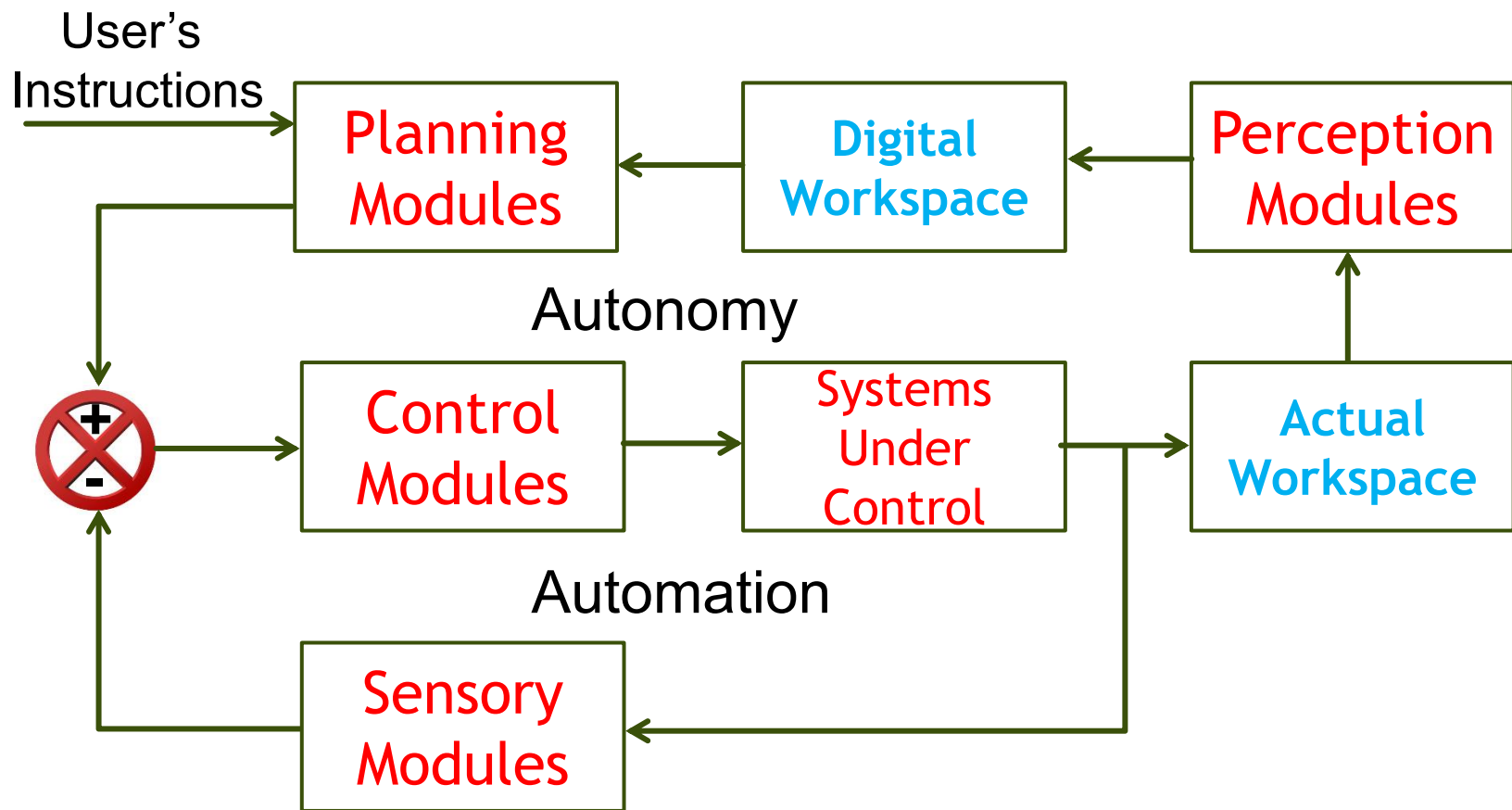

# Why to study this course?



**We are living inside an ocean of signals**

(Learning, Teaching) <o> (Research, Innovation) <o> (Leadership, Service)

# How to study this course?

- ▶ To put yourselves into the mindset of designers of networked sensors as products:
  - ▶ Who are the users?
  - ▶ What are the needs of users?
  - ▶ What are your Internet of Sensors, which could meet the needs of your users or buyers?
  - ▶ What are the solutions behind the design of your Internet of Sensors?

Practice with MATLAB

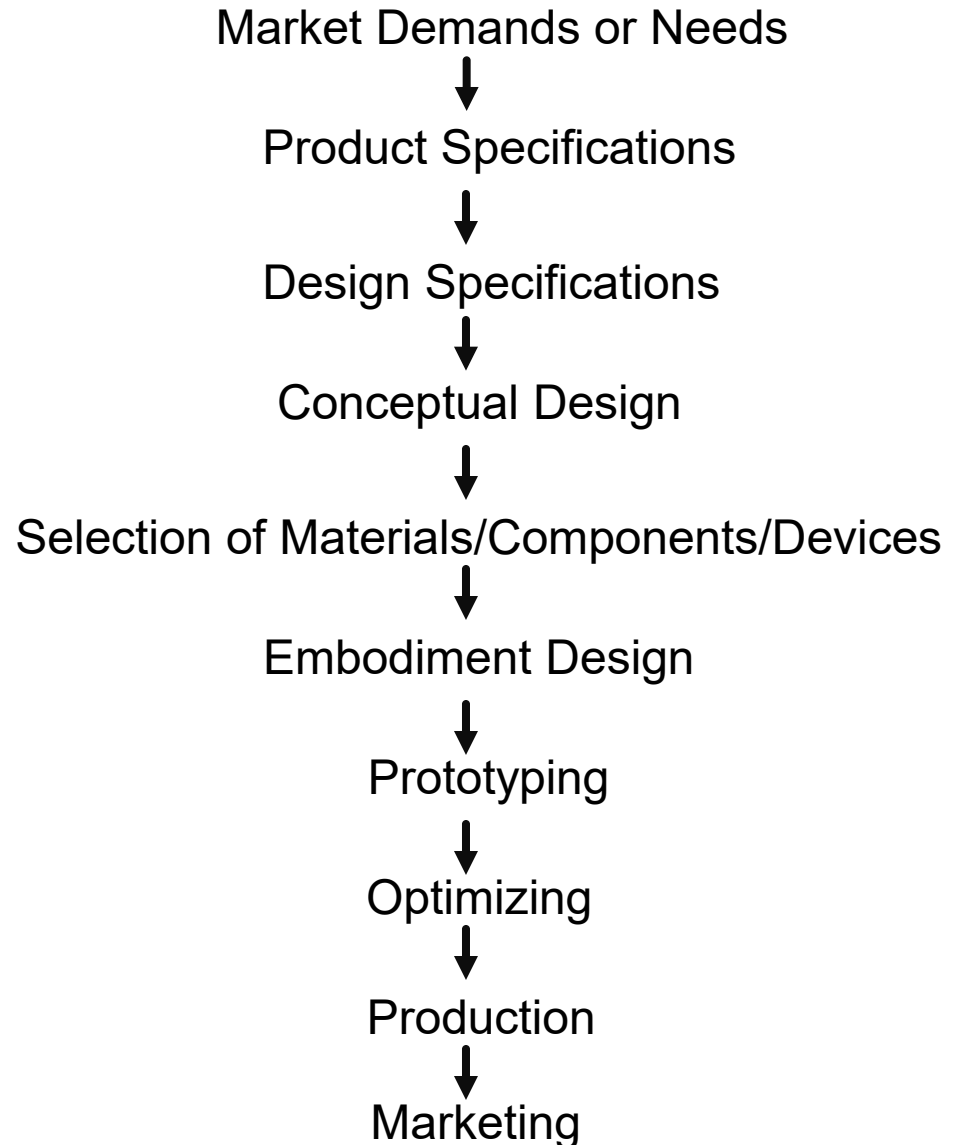

# What are you going to study in this course?

Module 1: Foundation of AI Sensors

- Basics of Physical World
- Randomness of Physical World
- Basics of Conceptual Worlds
- Fuzziness of Conceptual Worlds

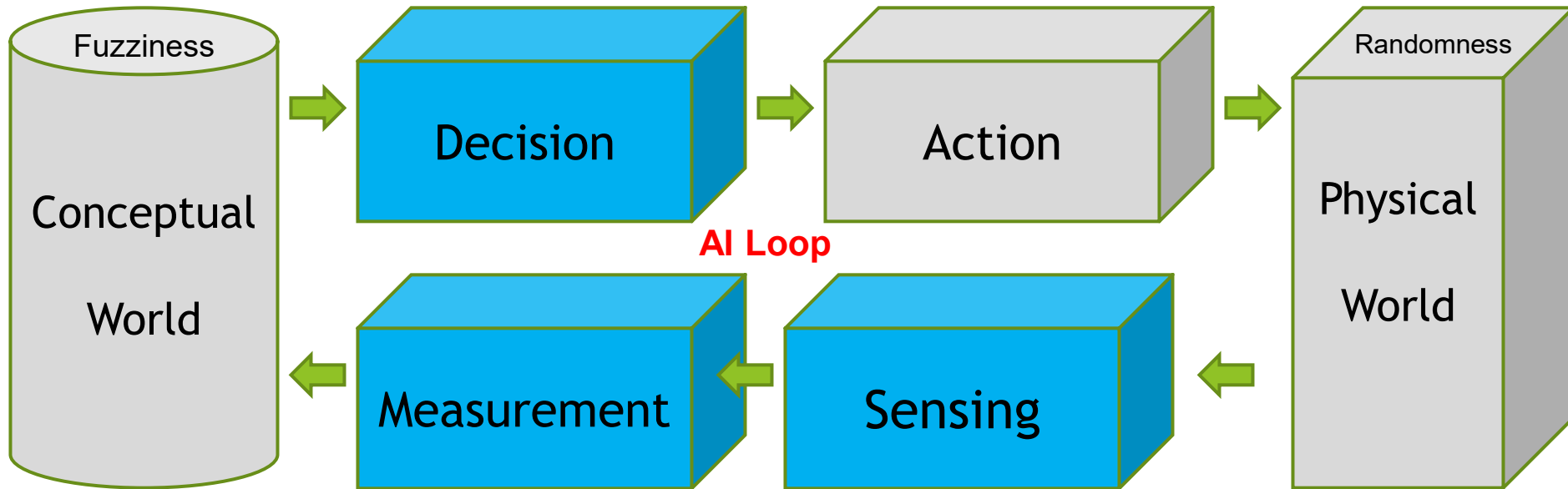

Module 2: For Electrical Systems

- Measurement of Voltage
- Measurement of Current
- Measurement of Resistance
- Measurement of Capacitance
- Measurement of Inductance

Module 3: For Mechanical Systems

- Measurement of Position
- Measurement of Velocity
- Measurement of Acceleration
- Measurement of Force
- Measurement of Torque

Module 4: For All Environments

- Measurement of Pressure
- Measurement of Temperature
- Measurement of Humidity
- Measurement of Vibration
- Measurement of Air Quality

Module 5: For All Industries

- Measurement of Fluid Level
- Measurement of Flow Rate
- Measurement of Sound/Voice
- Measurement of Photometry
- Measurement of Geometry

# How to apply?

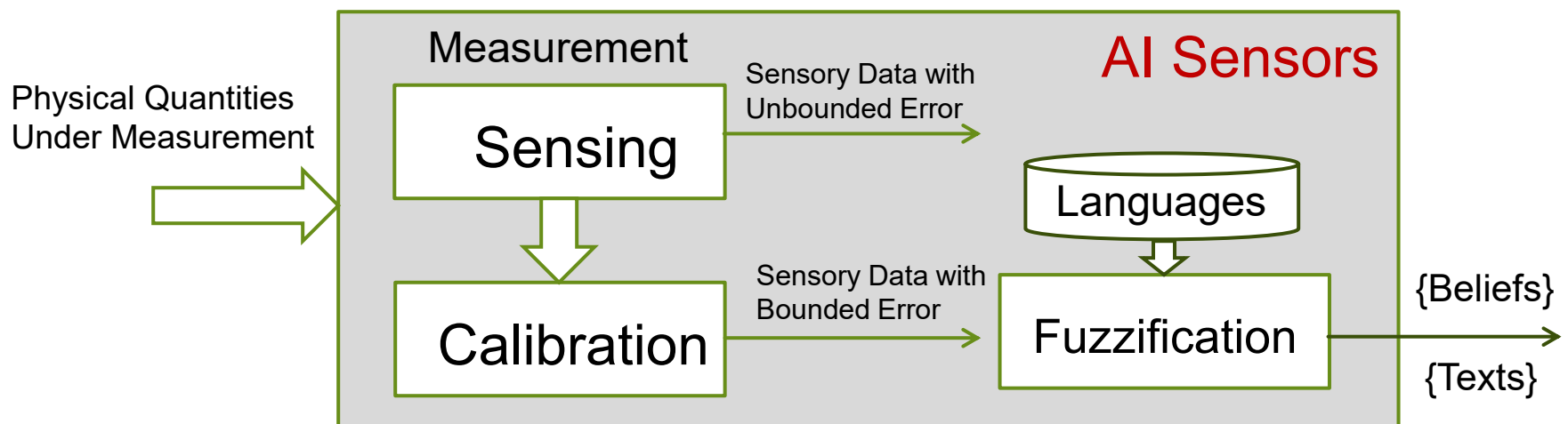
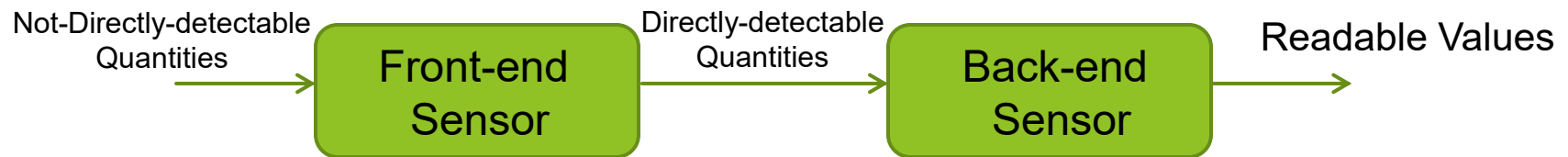

# Today's Lectures ...

- ▶ Module 1: Foundation of AI Sensors
- ▶ Module 2: Sensors for Electrical Systems
- ▶ Module 3: Sensors for Mechanical Systems
- ▶ **Module 4: Sensors for All Environments**
- ▶ Module 5: Sensors for All Industries



**NANYANG  
TECHNOLOGICAL  
UNIVERSITY**

**School of Mechanical & Aerospace Engineering**

Design, Machine, Control, Intelligence

Module 4

MA4822

# Sensors for All Environments

Xie Ming, PhD (France)

[mmxie@ntu.edu.sg](mailto:mmxie@ntu.edu.sg)

<http://personal.ntu.edu.sg/mmxie>

# Outline of Module 4

- ▶ Lecture 1:
  - ▶ Measurement of Pressure
- ▶ Lecture 2:
  - ▶ Measurement of Temperature
- ▶ Lecture 3:
  - ▶ Measurement of Humidity
- ▶ Lecture 4:
  - ▶ Measurement of Vibration
- ▶ Lecture 5:
  - ▶ Measurement of Air Quality

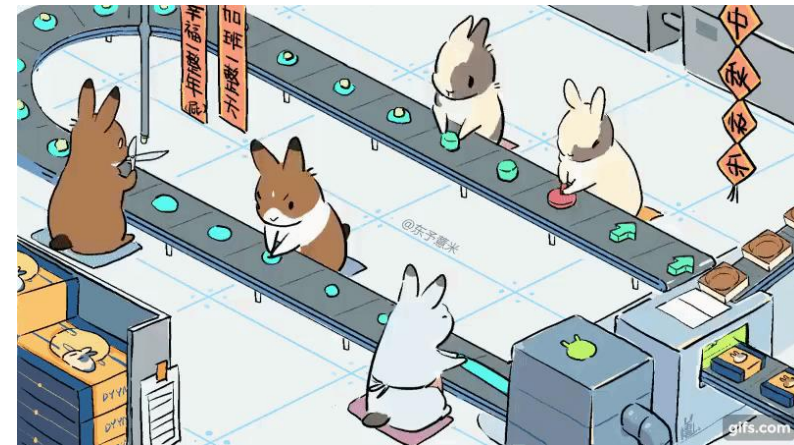

# Outline of Module 4

- ▶ Lecture 1:
  - ▶ Measurement of Pressure
- ▶ Lecture 2:
  - ▶ Measurement of Temperature
- ▶ Lecture 3:
  - ▶ Measurement of Humidity
- ▶ Lecture 4:
  - ▶ Measurement of Vibration
- ▶ Lecture 5:
  - ▶ Measurement of Air Quality

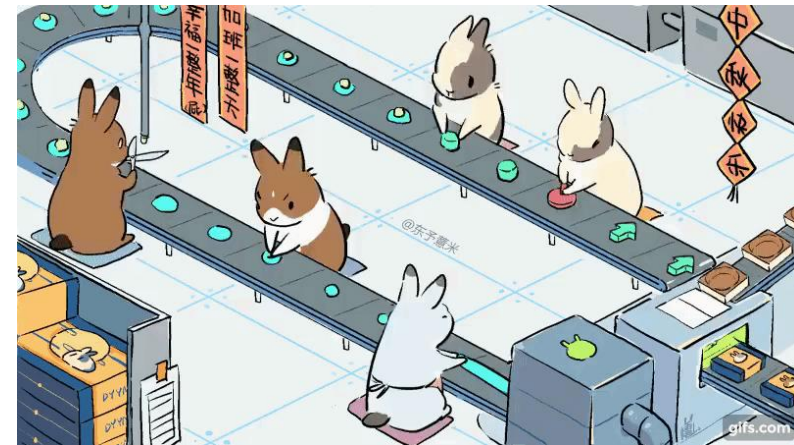



**NANYANG  
TECHNOLOGICAL  
UNIVERSITY**

**School of Mechanical & Aerospace Engineering**

Design, Machine, Control, Intelligence

Module 4 Lecture 1

MA4822

# Measurement of Pressure

Xie Ming, PhD (France)

[mmxie@ntu.edu.sg](mailto:mmxie@ntu.edu.sg)

<http://personal.ntu.edu.sg/mmxie>

# Outline

- ▶ Understanding of Pressure
- ▶ Computation of Pressure
- ▶ Measurement of Pressure

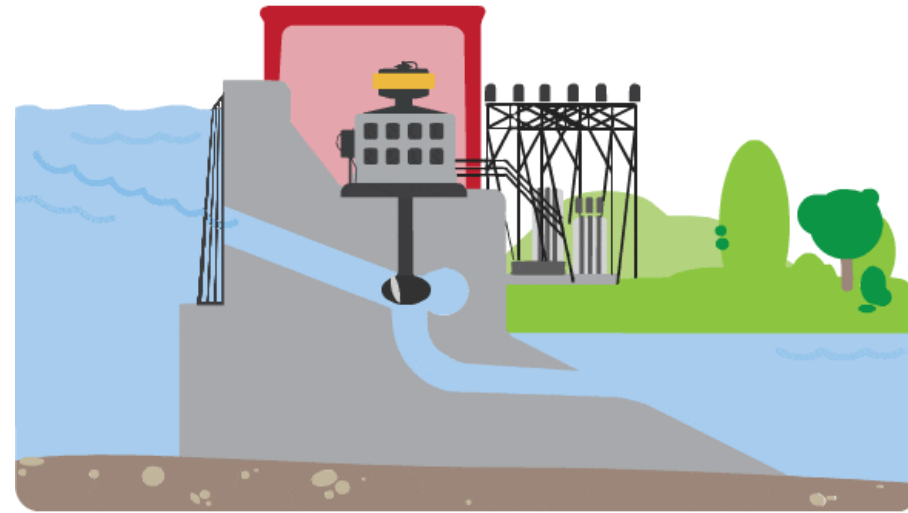

# Outline

- ▶ Understanding of Pressure
- ▶ Computation of Pressure
- ▶ Measurement of Pressure

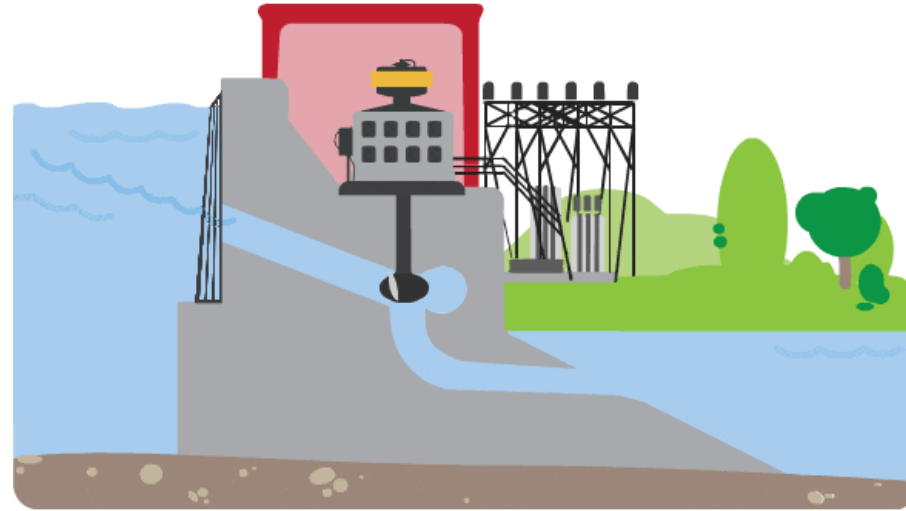

# Definition of Pressure

- ▶ Pressure is **the force per unit area** applied perpendicularly to the surface of an object (e.g. **sensing elements**), over which the force is distributed.

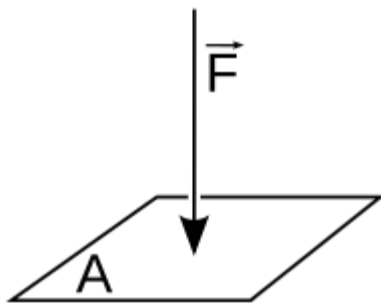

$$\begin{aligned}\text{Pressure} &= \frac{\text{Perpendicular force}}{\text{Surface area on which the force is acting}} \\ \text{Pressure} &= \frac{\text{N}}{\text{m}^2} \\ &= \text{N m}^{-2} \text{ (Newtons per square metre)}\end{aligned}$$

# Unit of Measurement of Pressure

## Conversion Table

V · T · E	Pascal (Pa)	Bar (bar)	Technical atmosphere (at)	Standard atmosphere (atm)	Torr (Torr)	Pounds per square inch (psi)
1 Pa	$\equiv 1 \text{ N/m}^2$	$10^{-5}$	$1.0197 \times 10^{-5}$	$9.8692 \times 10^{-6}$	$7.5006 \times 10^{-3}$	$1.450377 \times 10^{-4}$
1 bar	$10^5$	$\equiv 100 \text{ kPa}$ $\equiv 10^6 \text{ dyn/cm}^2$	1.0197	0.986 92	750.06	14.503 77
1 at	$9.80665 \times 10^4$	0.980 665	$\equiv 1 \text{ kp/cm}^2$	0.967 8411	735.5592	14.223 34
1 atm	$1.01325 \times 10^5$	1.013 25	1.0332	1	$\equiv 760$	14.695 95
1 Torr	133.3224	$1.333224 \times 10^{-3}$	$1.359551 \times 10^{-3}$	$1.315789 \times 10^{-3}$	$\equiv 1/760 \text{ atm}$ $\approx 1 \text{ mmHg}$	$1.933678 \times 10^{-2}$
1 psi	$6.8948 \times 10^3$	$6.8948 \times 10^{-2}$	$7.03069 \times 10^{-2}$	$6.8046 \times 10^{-2}$	51.714 93	$\equiv 1 \text{ lbf/in}^2$

Basic Unit of Measurement

1 atm = 101.3 kPa

# Illustration of Atmospheric Pressure

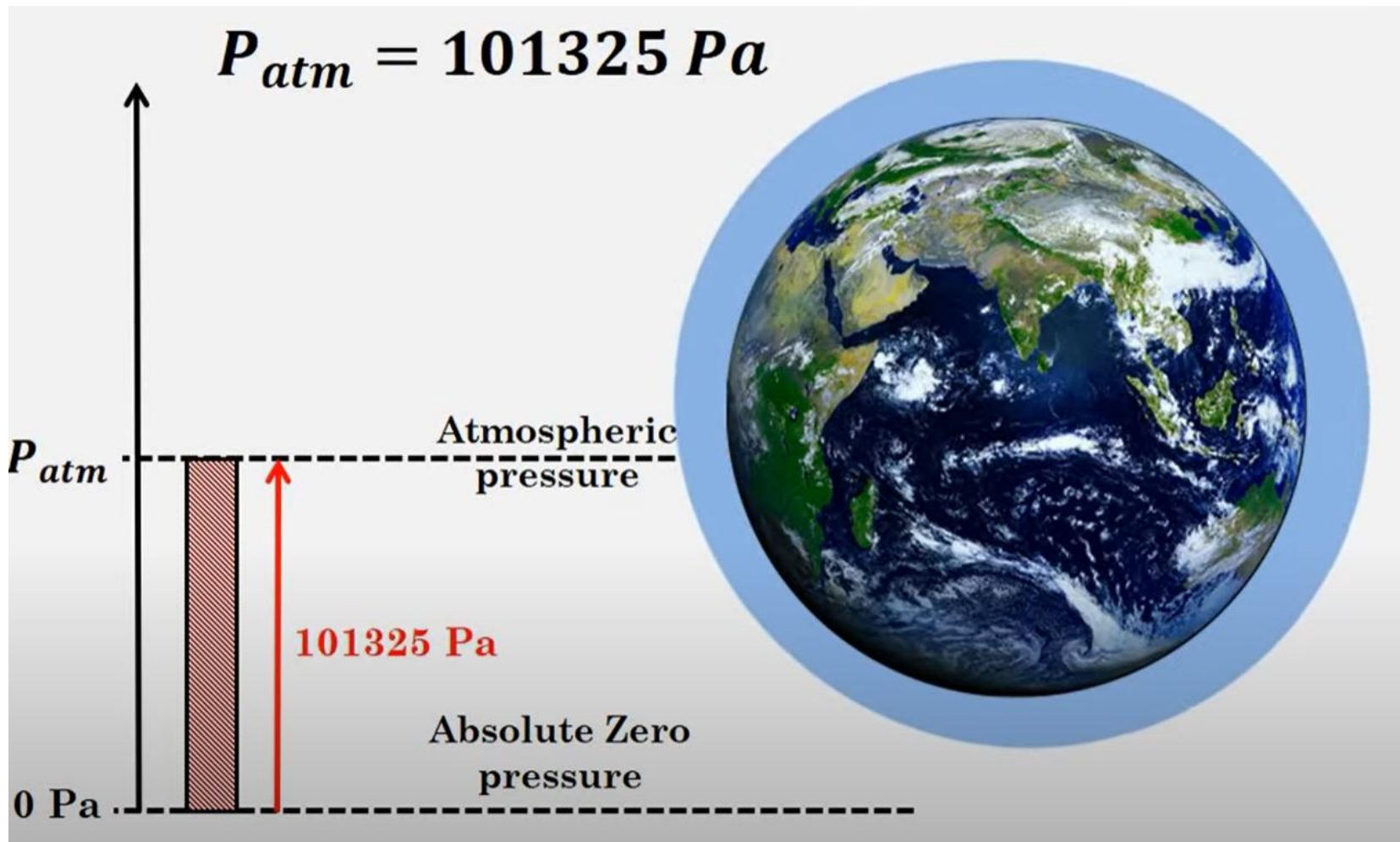

# There Are Three Different Types of Pressures

- ▶ Absolute pressures
- ▶ Gauge pressures (including vacuum pressures also known as negative pressures)
- ▶ Differential pressures

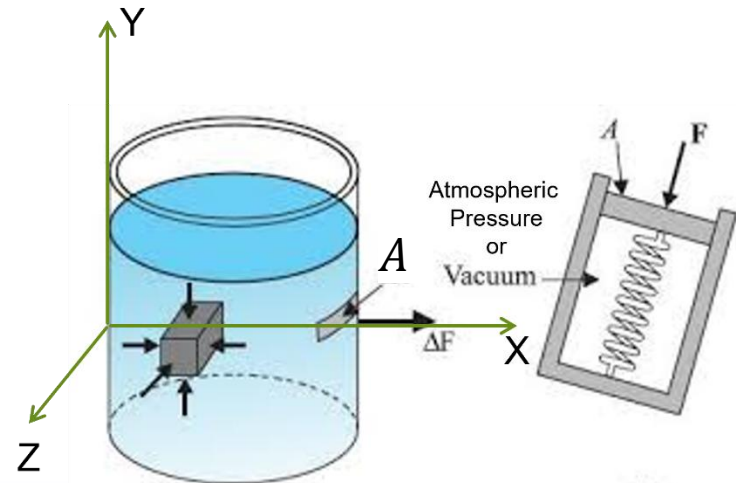

Absolute Pressure	Gauge Pressure	Differential Pressure

# Illustration of Difference between Absolute Pressure and Gauge Pressure

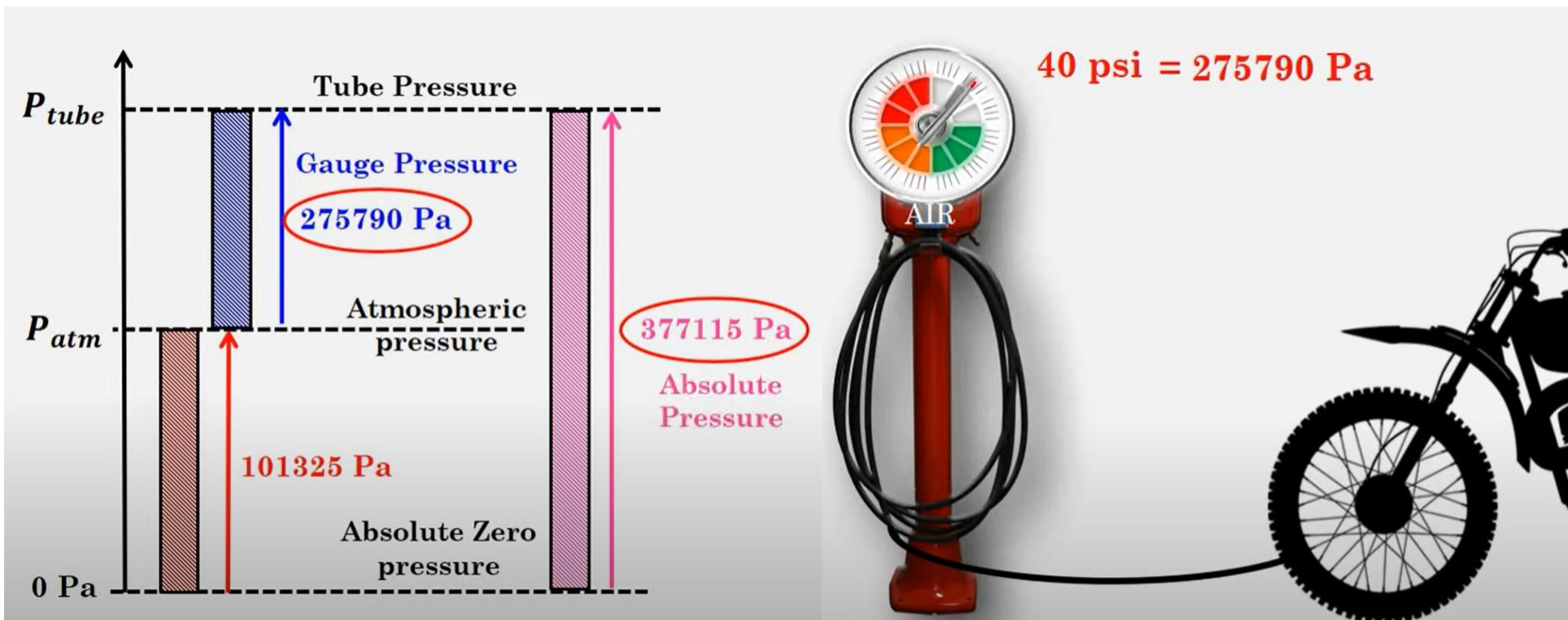

# Concept of Vacuum Pressure (i.e. Negative Pressure Relative to 1 atm)

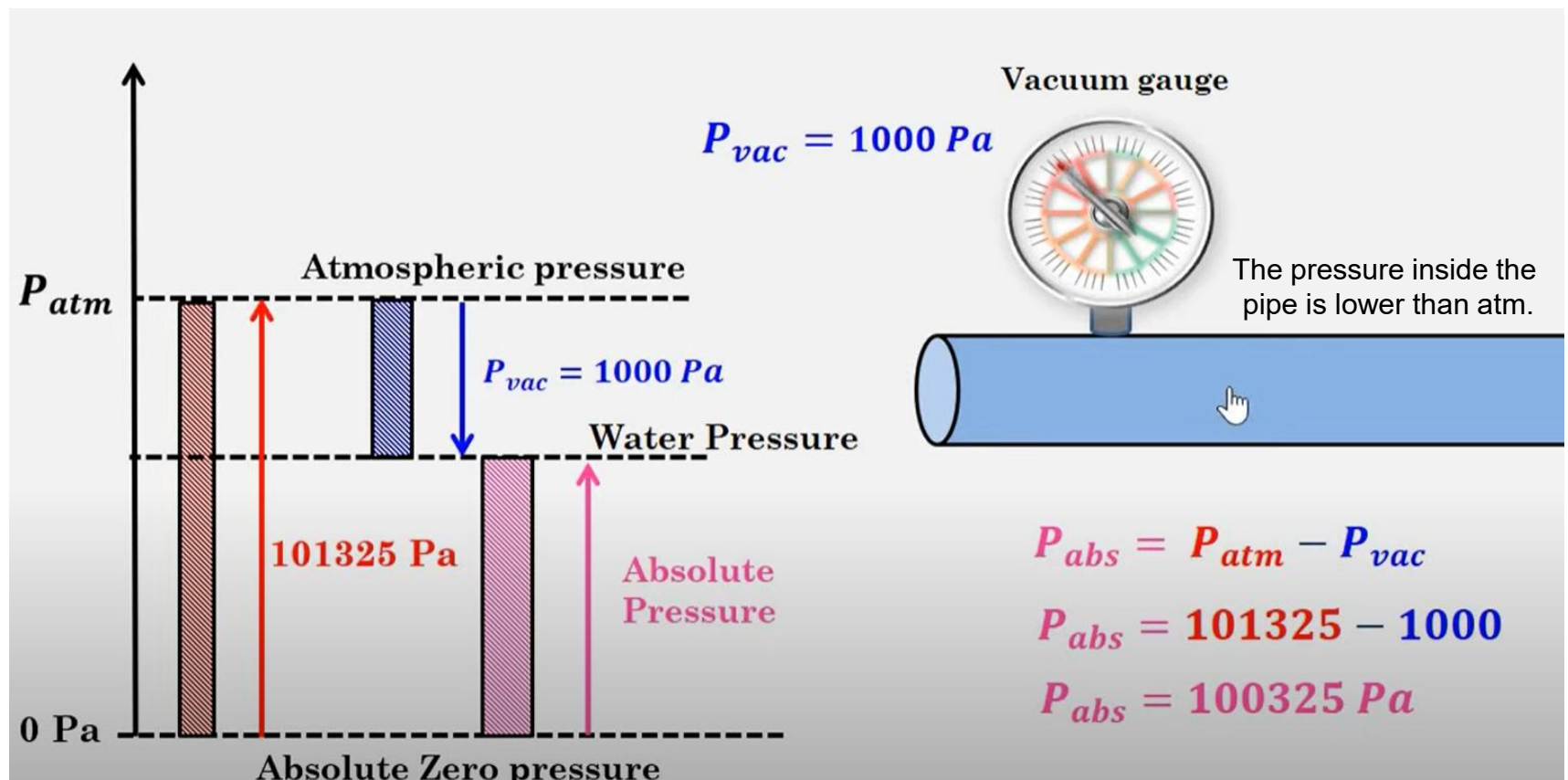

# Comparison between Gauge Pressure and Vacuum Pressure

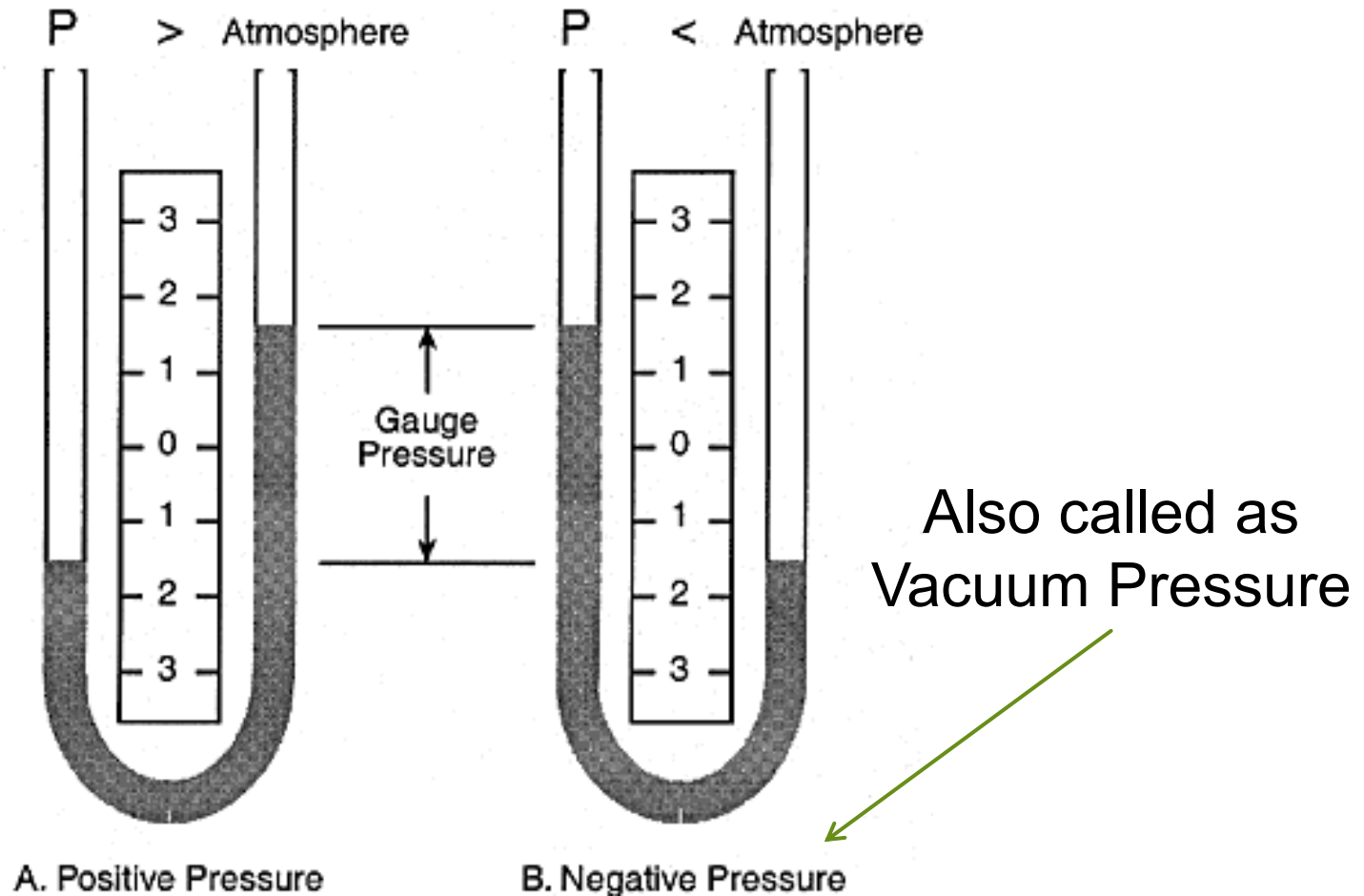

# Applied Forces in Pressure Can Come From:

- ▶ Objects in solid state
- ▶ Objects in liquid state
- ▶ Objects in gas state

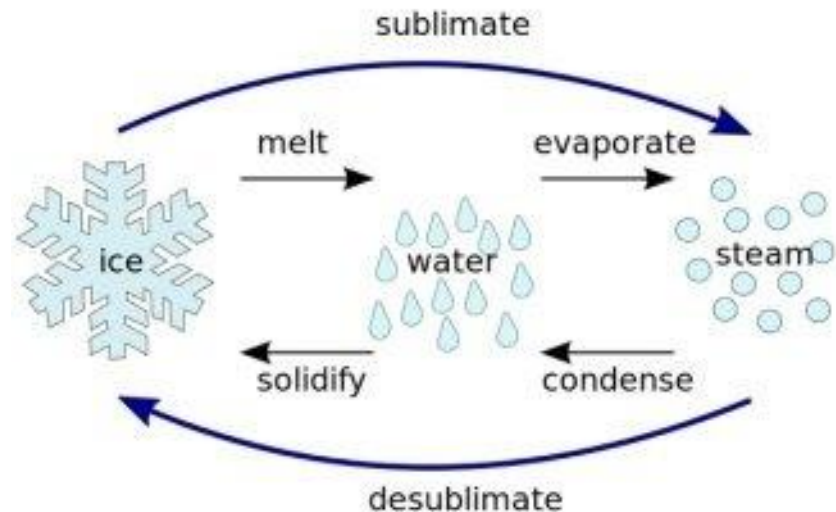

# Hence, pressure could be produced by ...

- ▶ Solid
- ▶ Liquid
- ▶ Gas

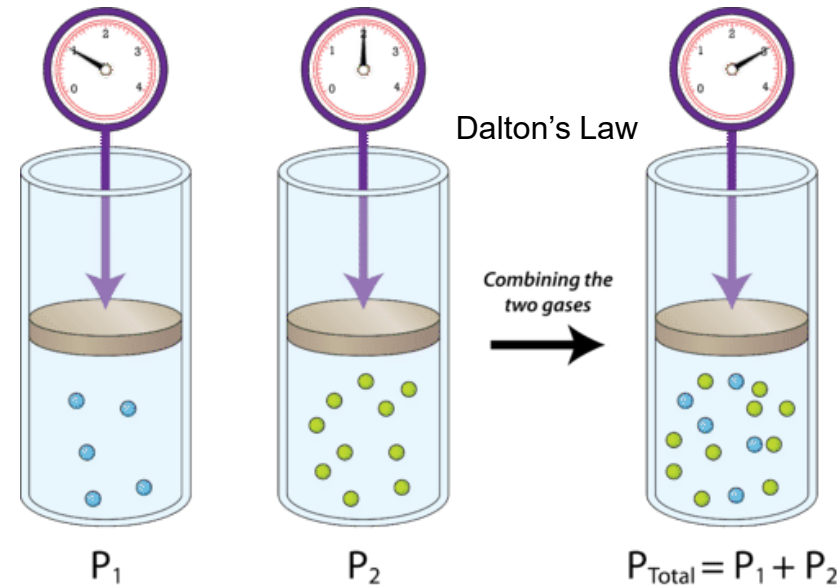
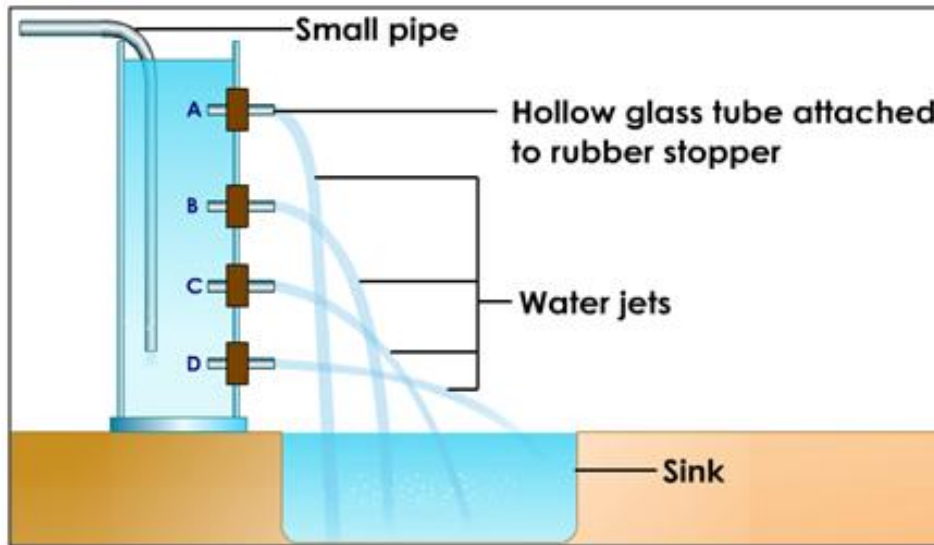
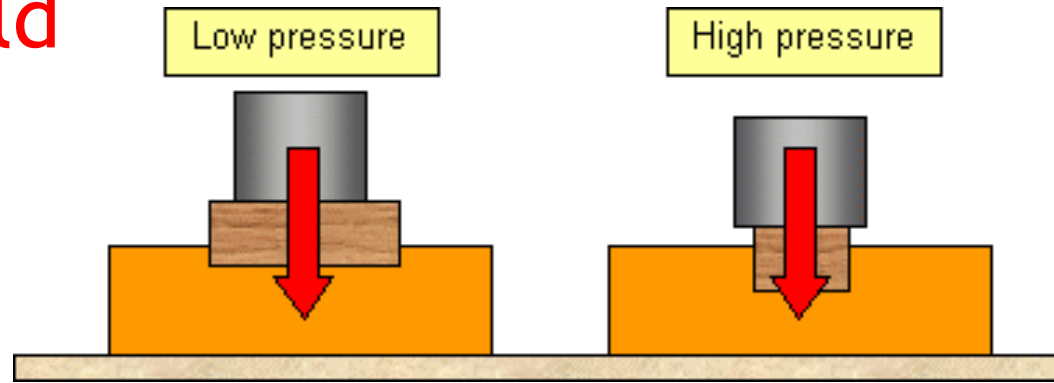

Volume and temperature are constant

# Case 1: Pressure is produced by particles (State of Gas)

Closed Space

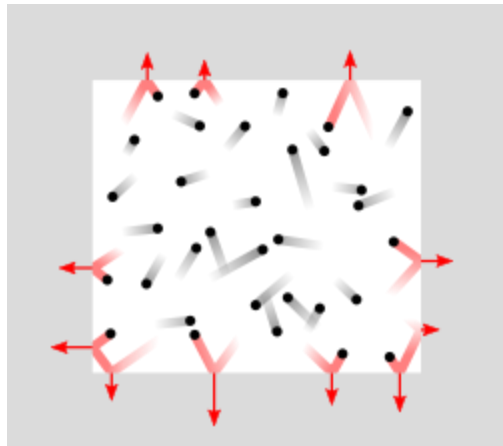

Open Space

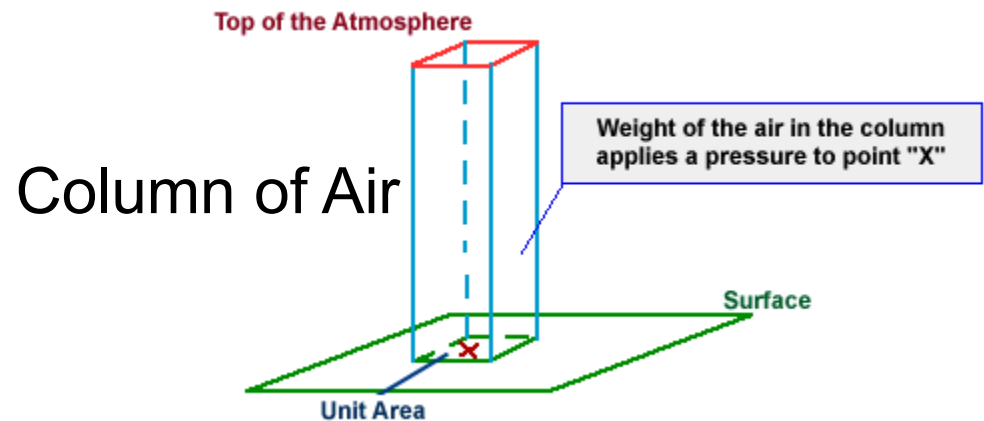

Equation of Ideal Gas:

$$P = \frac{nRT}{V}$$

$$R = 0.0821 \text{ atm L/Mol K}$$

$$R = 8.31 \text{ kPa L/Mol K}$$

# Example of Constant Volume

$$P = \frac{nRT}{V}$$

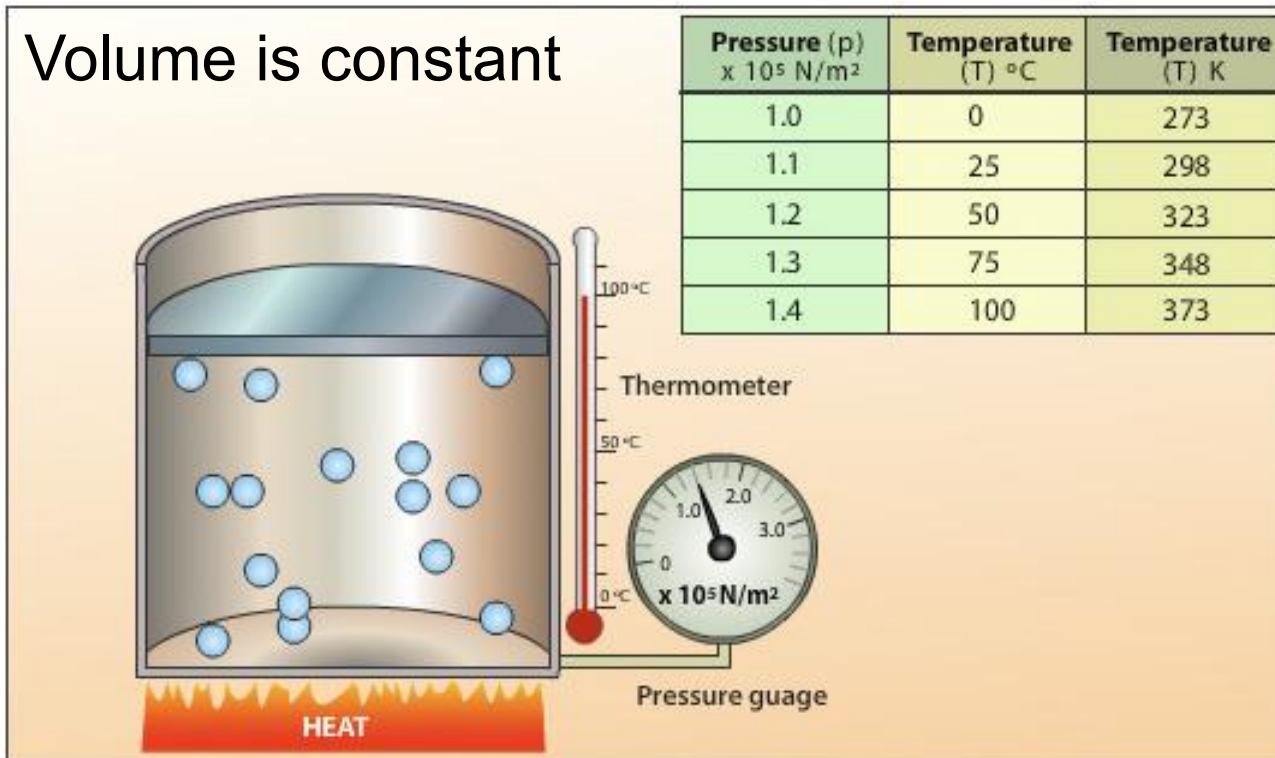

# Example of Constant Temperature

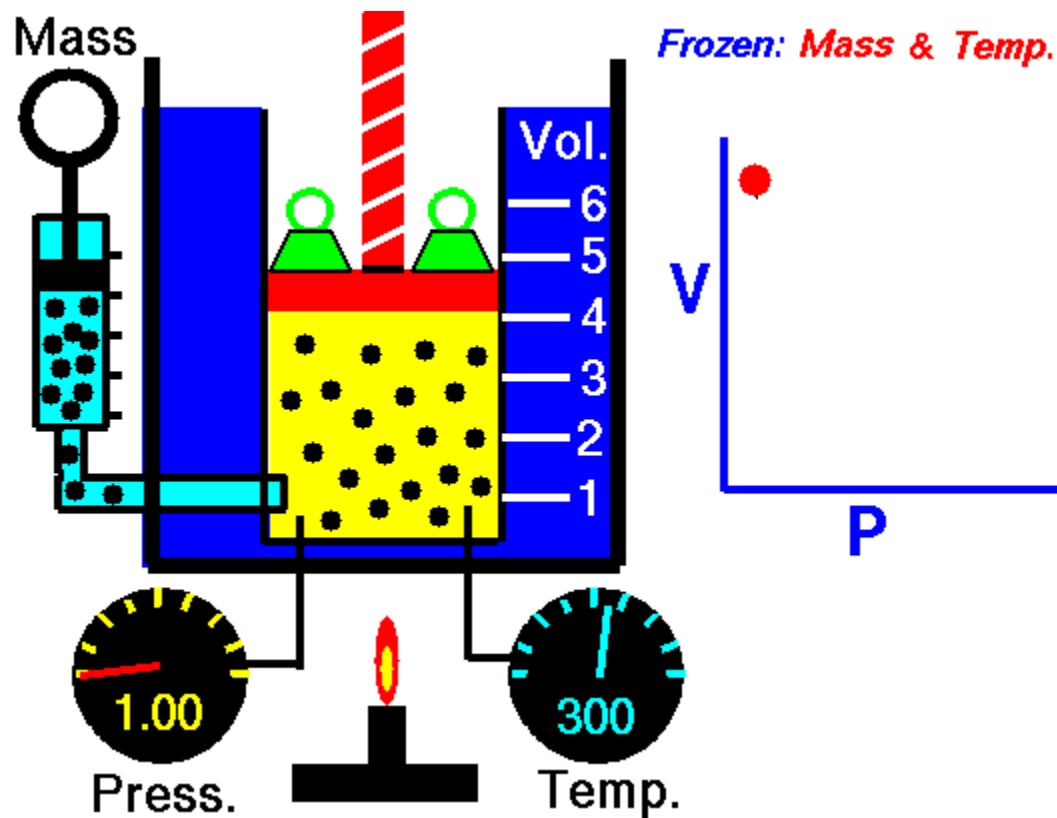

$$P = \frac{nRT}{V}$$

# Example of Dalton's Law

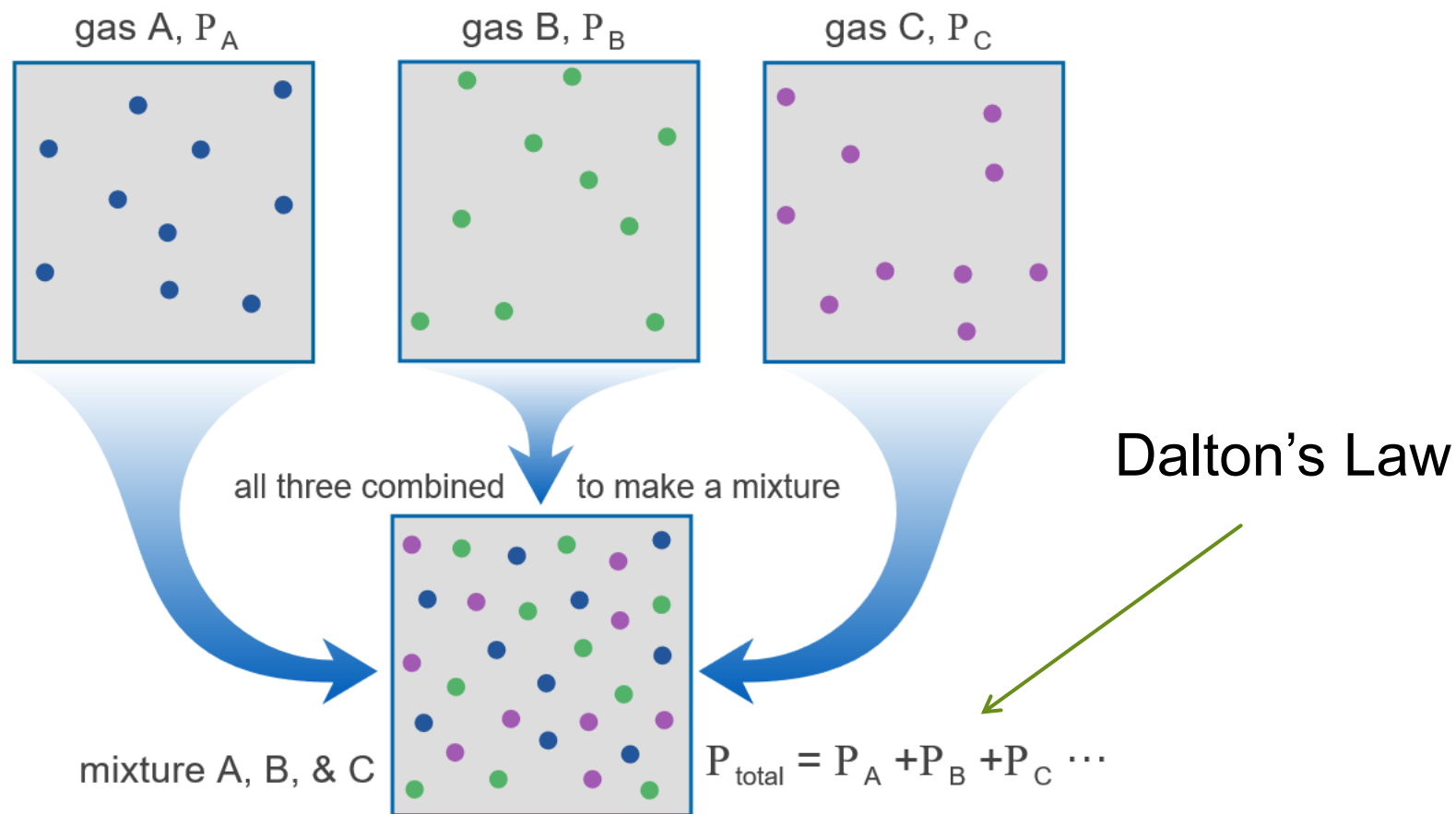

## Case 2: Pressure is produced by fluids (State of Liquid)

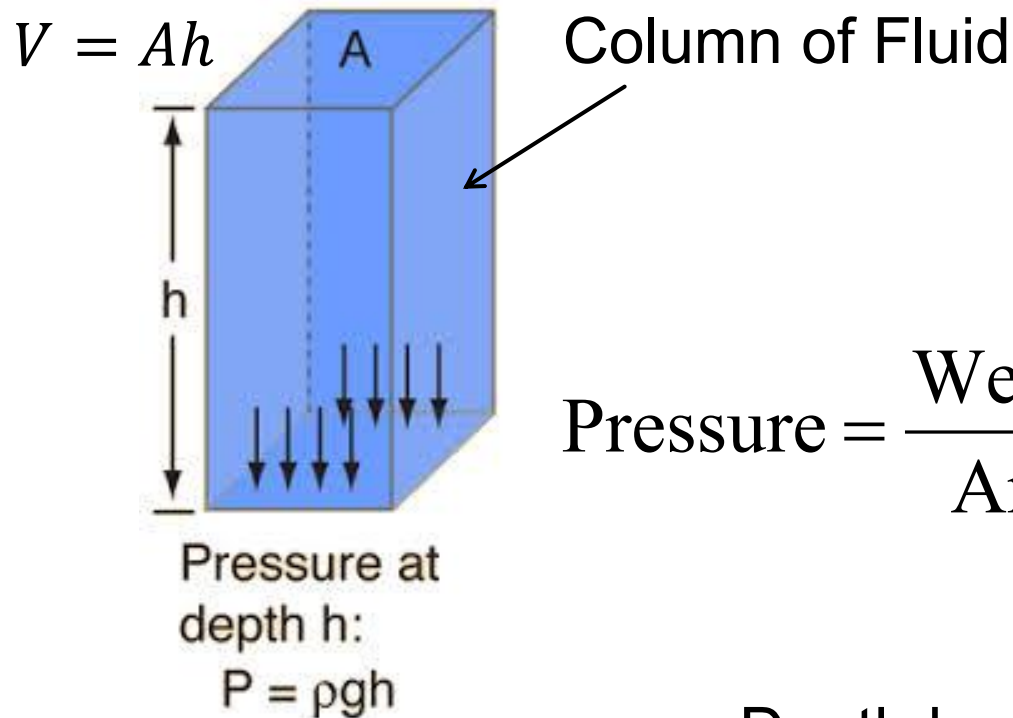

$$\text{Pressure} = \frac{\text{Weight}}{\text{Area}} = \frac{mg}{A} = \frac{\rho Vg}{A} = \rho hg$$

Depth here refers to vertical depth

# Example Showing Pressure Equality at Same Vertical Depth

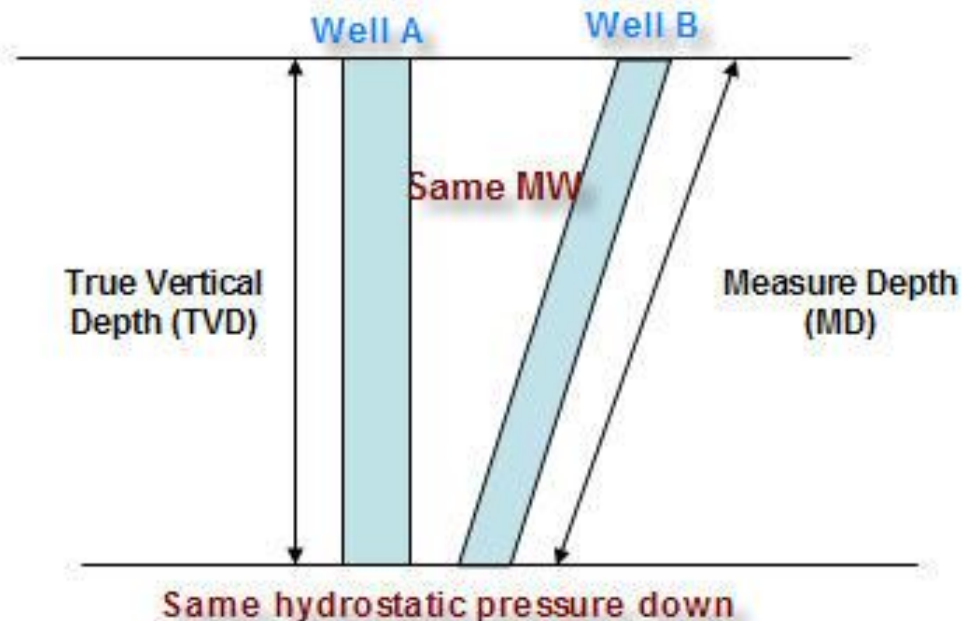

# Example Showing Pressure Equality at Same Vertical Depth

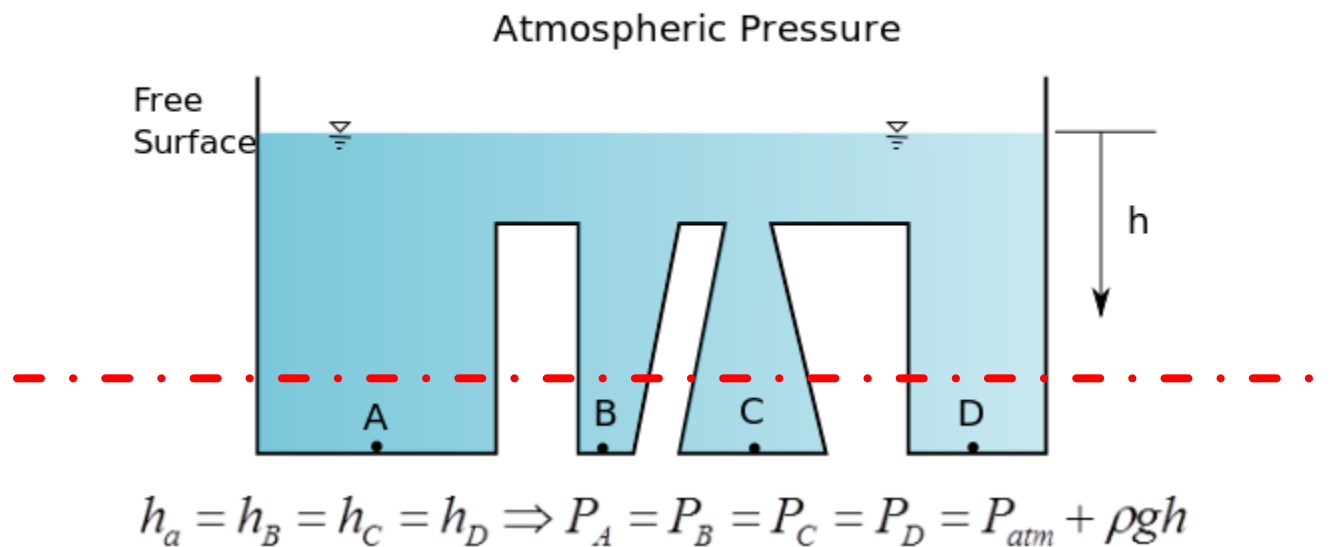

# Bernoulli's Equation:

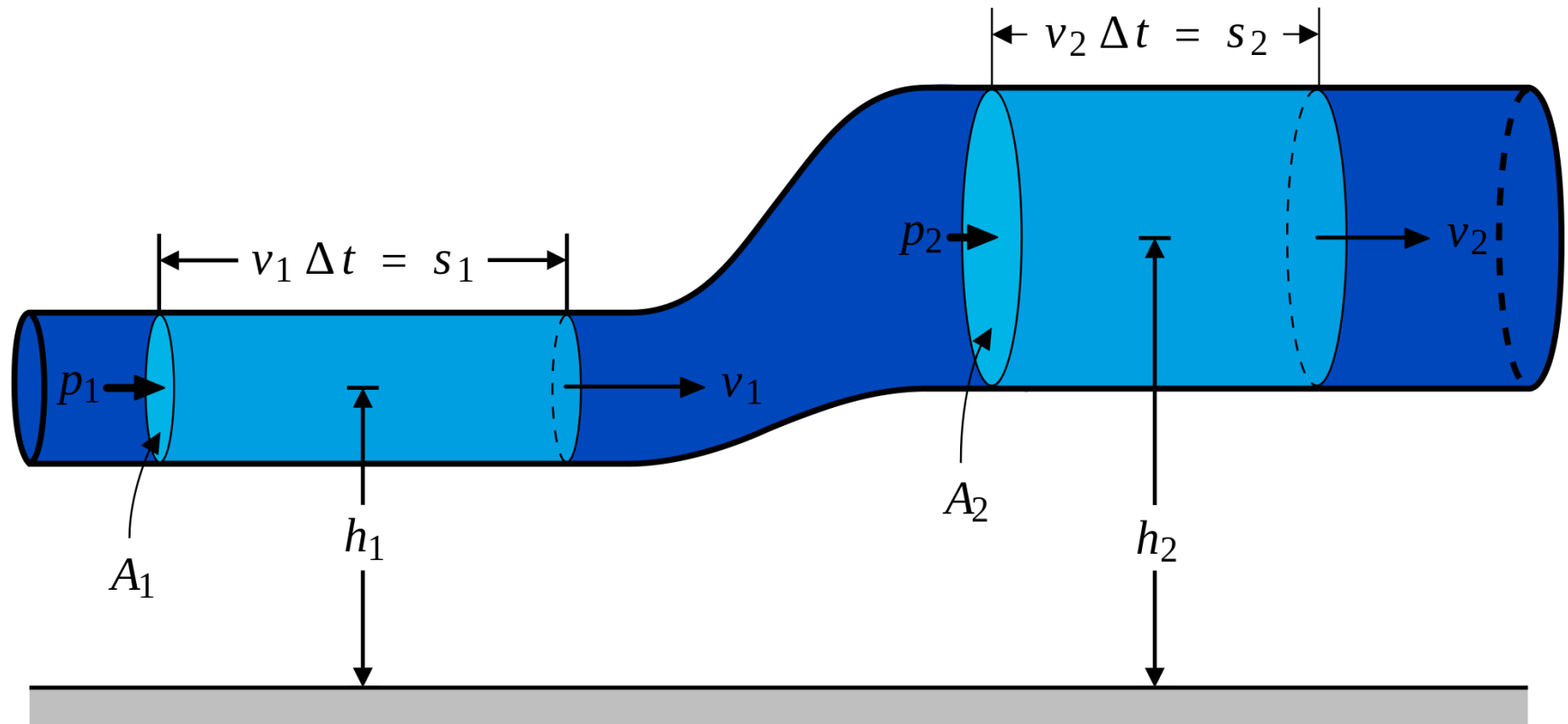

$$P + \rho h g + \frac{1}{2} \rho v^2 = \text{Constant}$$

## Case 3: Pressure is produced by rigid objects (State of Solid)

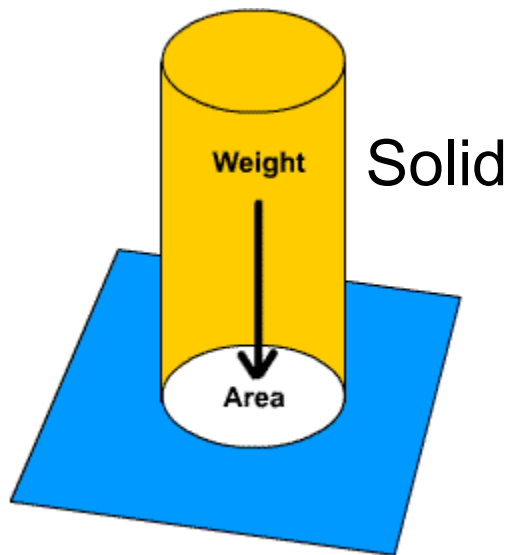

$$P = \frac{mg}{A}$$

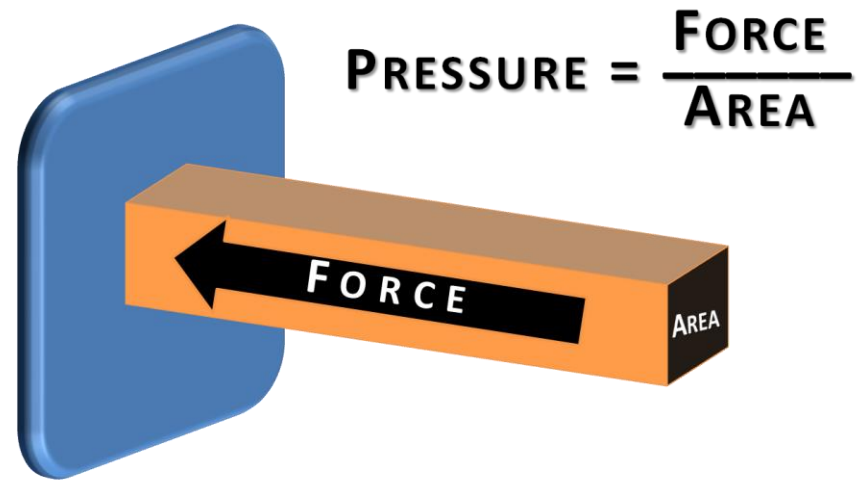

# Outline

- ▶ Understanding of Pressure
- ▶ Computation of Pressure
- ▶ Measurement of Pressure

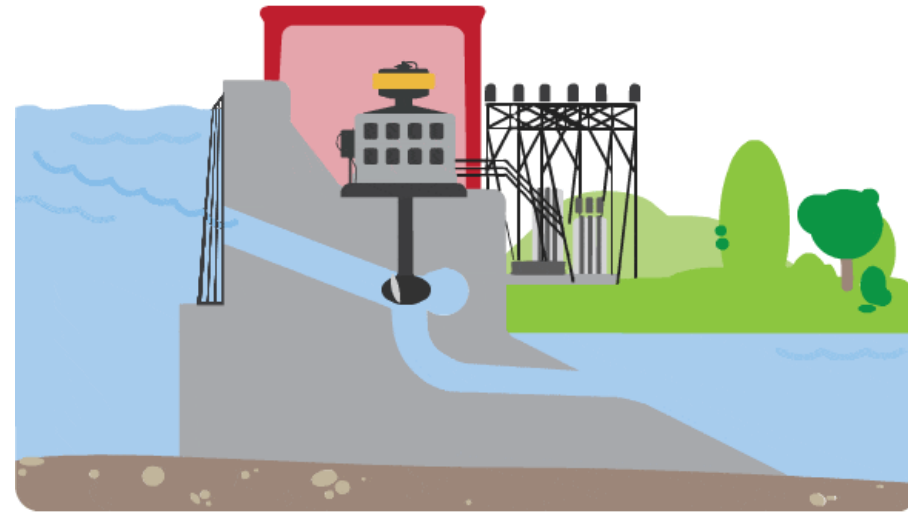

# Example of Computing Gauge Pressure

$$P_1 = P + \rho g \Delta h$$

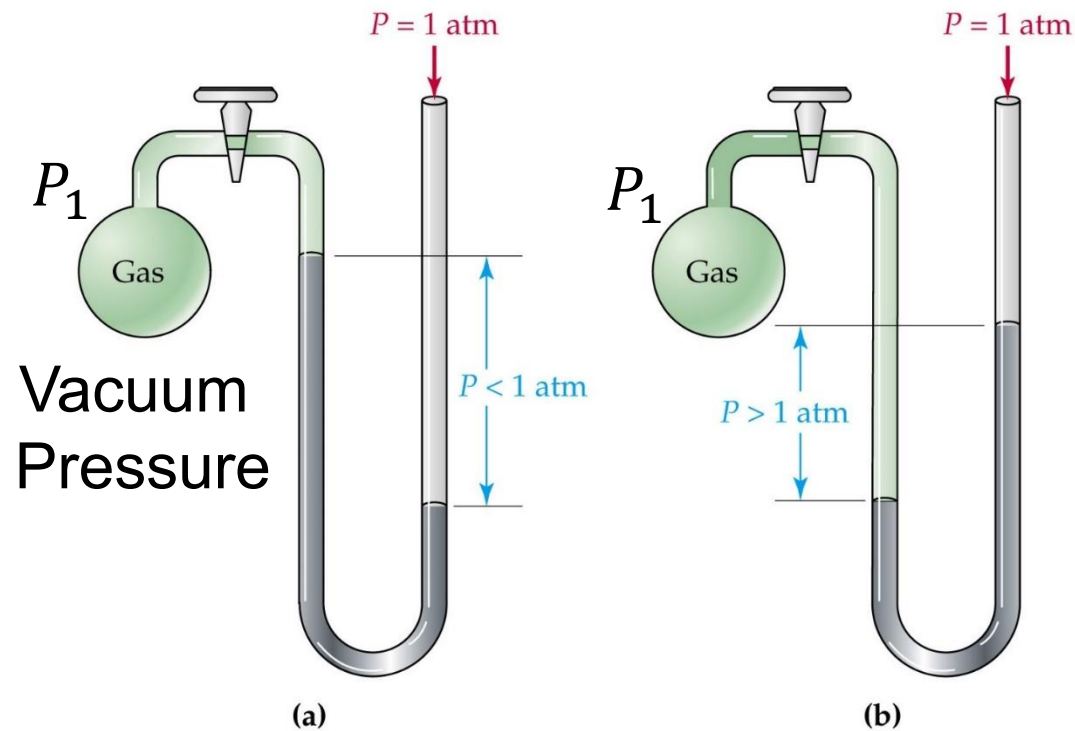

# Example of Computing Differential Pressure

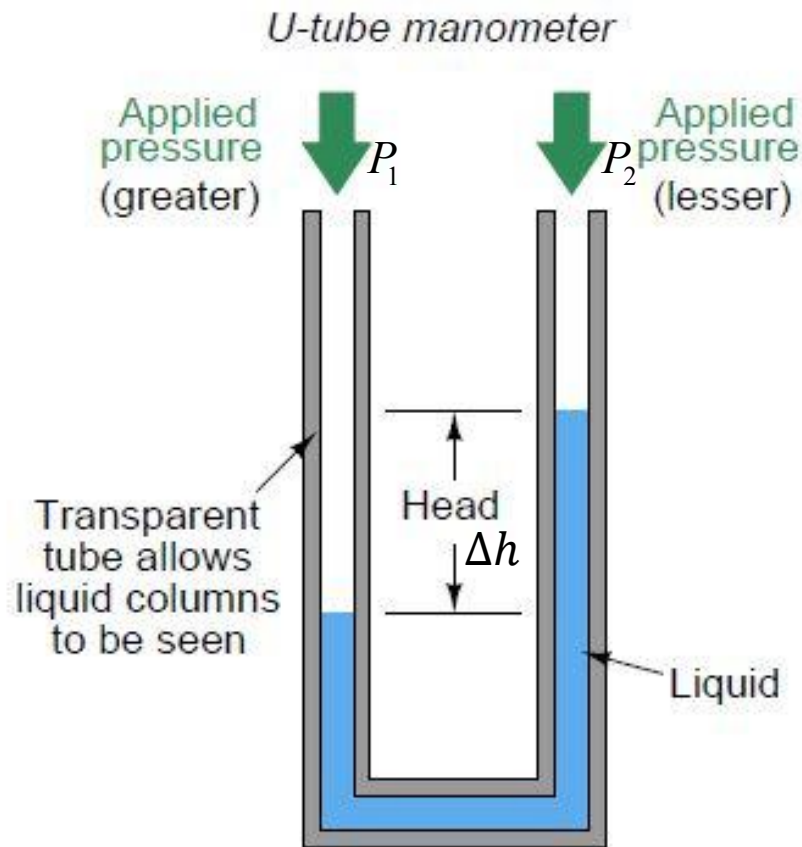

$$P_1 = P_2 + \rho g \Delta h$$

# Example of Computing Pressure of Liquid

- ▶ As shown in the figure, a u-tube contains mercury with the density of  $13.5 \text{ g/cm}^3$ . The value of  $h$  is  $10.0 \text{ mm}$ . The atmospheric pressure is  $1.0 \text{ atm}$ . What is the unknown pressure  $P$ ?

- ▶ Answer:

$$P = P_0 + \Delta P$$

$$P = P_0 + \rho gh$$

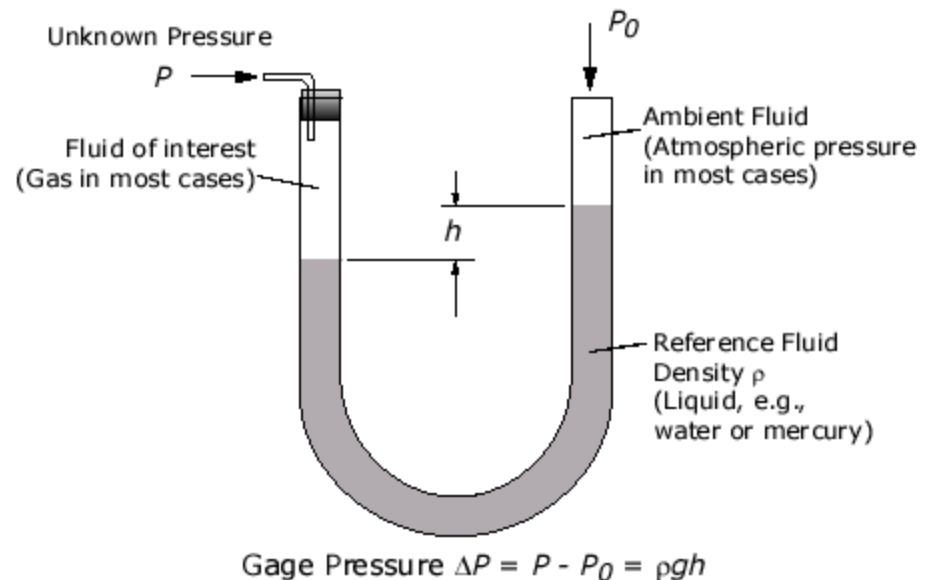

$$P = 101.3 \times 10^3 \text{ Pa} + \left(13.5 \times \frac{10^{-3}}{0.01^3}\right) \times 9.81 \times 0.01$$

$$P = 101.3 \times 10^3 \text{ Pa} + 1.2 \times 10^3 \text{ Pa}$$

# Example of Computing Pressure of Liquid

- ▶ As shown in the figure, the u-tube contains mercury with the density of  $13.5 \text{ g/cm}^3$ . The values of  $h_1$  and  $h_2$  are  $23.0 \text{ cm}$  and  $20.0 \text{ cm}$ , respectively. What is the pressure difference between point A and point B?

- ▶ Answer:

$$\Delta P = \rho g \Delta h$$

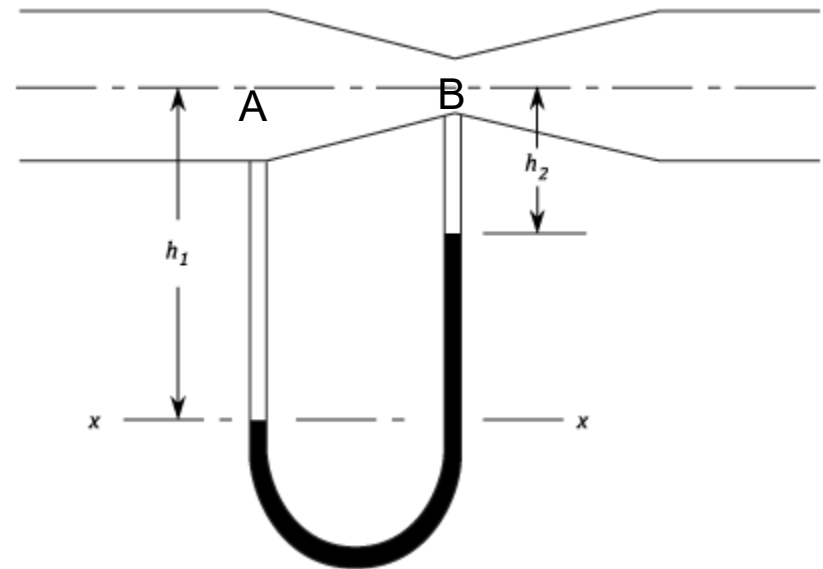

$$\Delta P = 13.5 \times 10^{-3} \times 10^6 \times 9.8 \times (23.0 - 20.0) \times 10^{-2}$$

$$\Delta P = 3.973 \text{ kPa}$$

# Example of Computing Pressure of Gas

- ▶ A tire contains 5.0 litres of air. The mole number is 0.225 mol. If the temperature of the air inside is 30.0 Celsius, what is the pressure of the air inside the tire?

- ▶ Answer:

$$P = \frac{nRT}{V}$$

$$P = \frac{0.225 \times 0.0821 \times (273 + 30)}{5.0}$$

$$P = 1.119 \text{ atm}$$

$$R = 0.0821 \text{ atm L/Mol K}$$

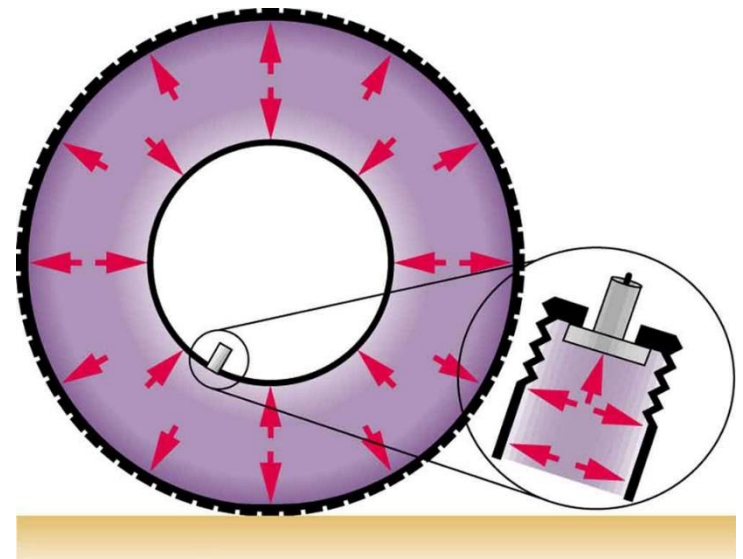

# Example of Computing Pressure of Solid

- ▶ What is the pressure applied to the table by the book?

- ▶ Answer of Case 1:

$$P = \frac{11.1 \times 10^3}{0.2 \times 0.5} = 111 \text{ kPa}$$

- ▶ Answer of Case 2:

$$P = \frac{11.1 \times 10^3}{1.0 \times 0.5} = 22.2 \text{ kPa}$$

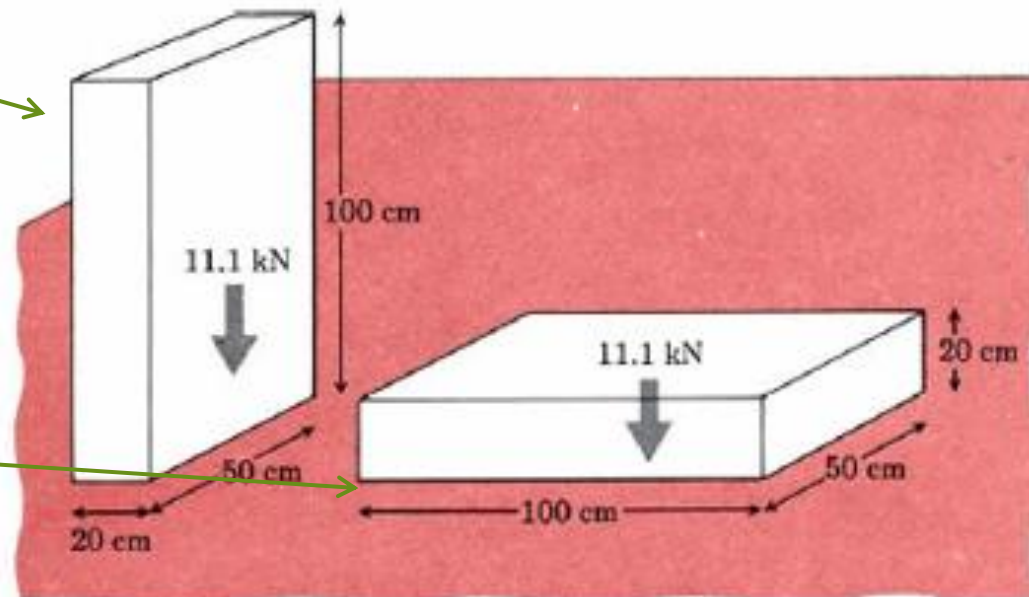

## Example of Computing Pressure of Solid

- ▶ The mass of an elephant is 500.0 kg. And, the elephant's foot surface is 100.0 cm<sup>2</sup>. If the elephant stands up with two legs as shown in the figure. What is the pressure exerted by the two standing feet on the ground?

- ▶ Answer:

$$P = \frac{W}{A} = \frac{mg}{A}$$

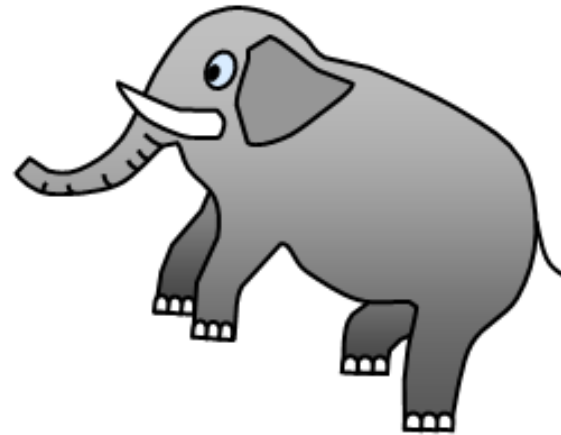

$$P = \frac{500 \times 9.81}{2 \times 100.0 \times (0.01)^2} = 245.25 \text{ kPa}$$

# Outline

- ▶ Understanding of Pressure
- ▶ Computation of Pressure
- ▶ Measurement of Pressure

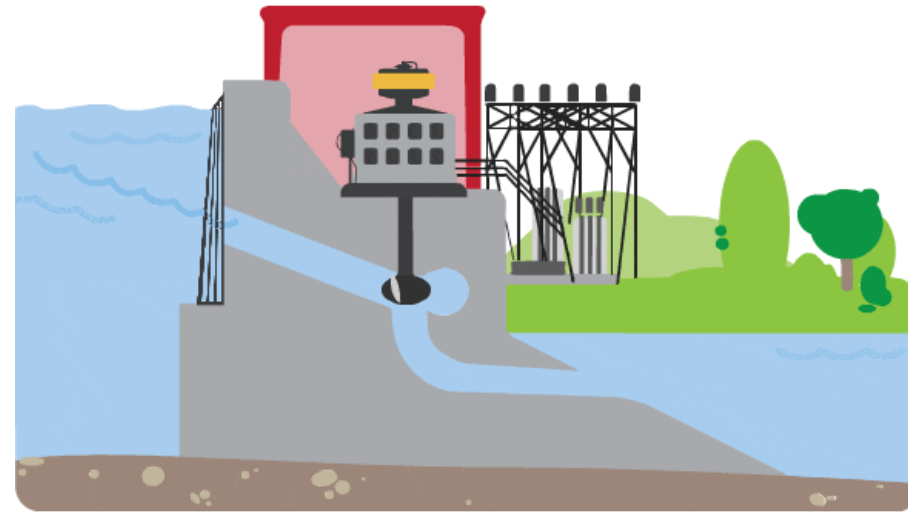

# Applications in Industry



# Applications in Daily Life



# Interesting applications in medical field (e.g. smart shoes)

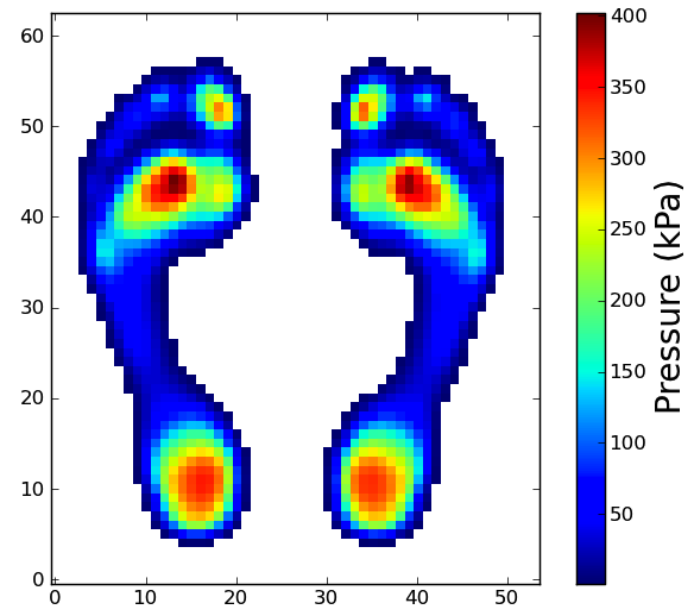

# Other Applications

## Smart Carpet

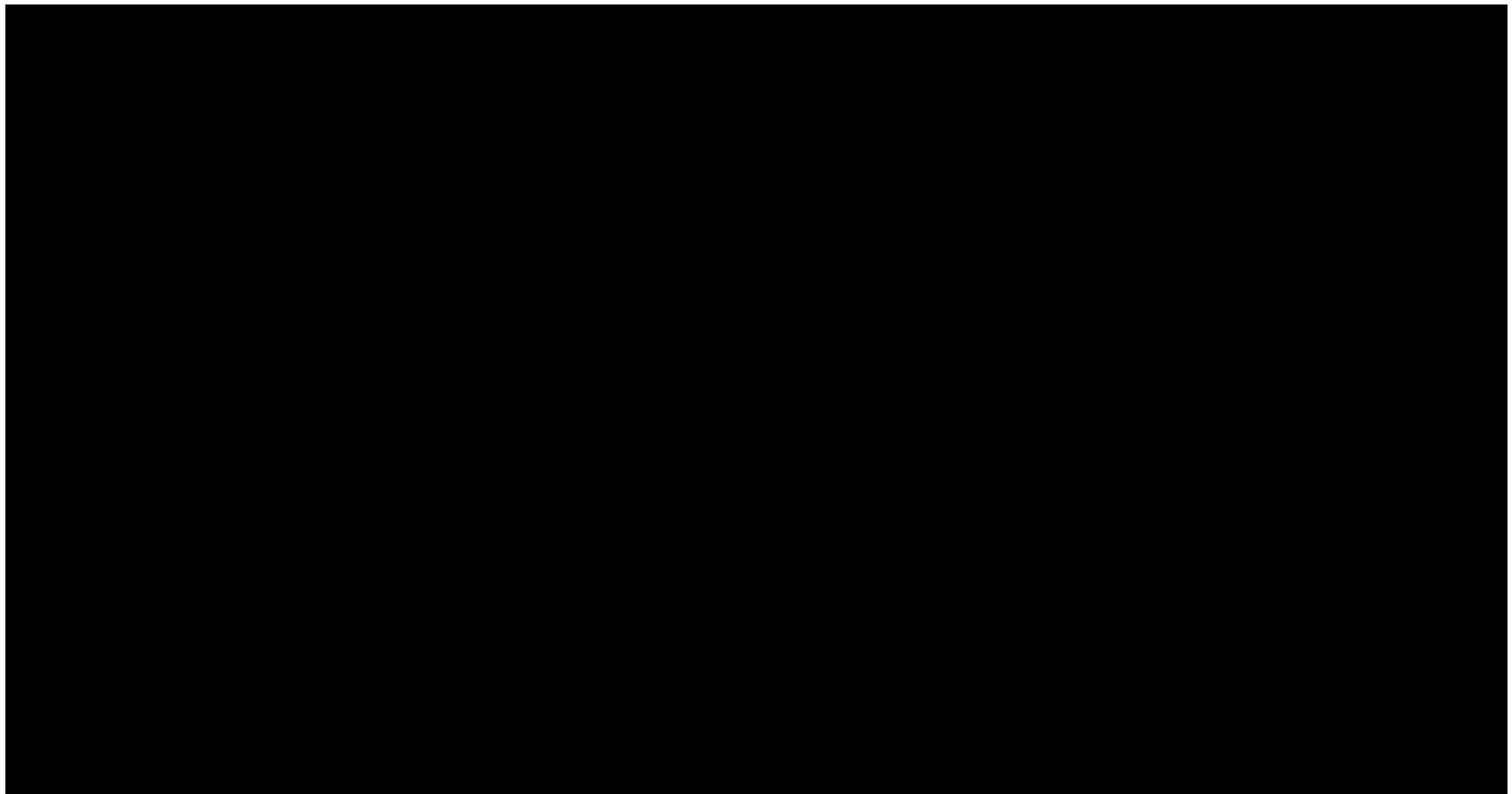

## Other Applications (continued)



# Other Applications (continued)

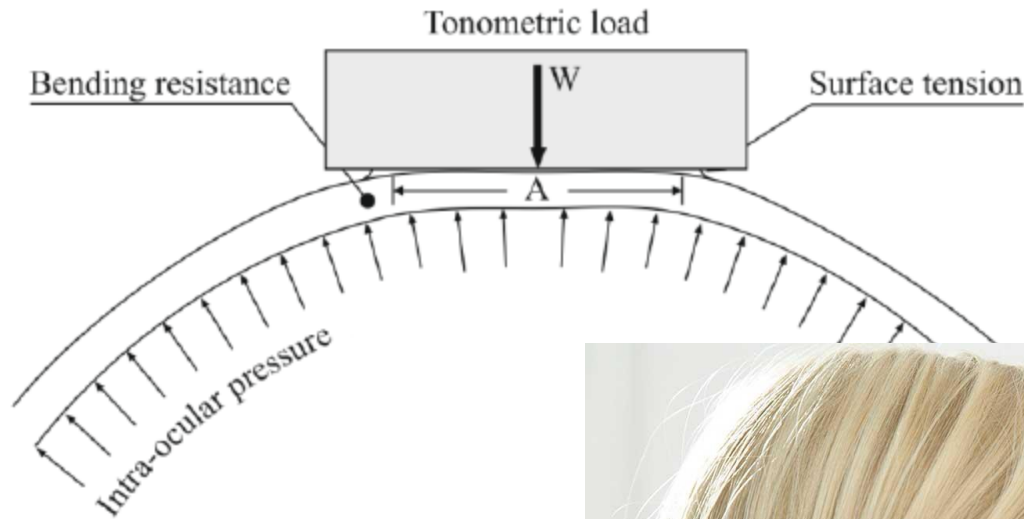

# Principles of Measurement

- ▶ **Principle 1:** Pressure (or pressure variation at a diaphragm) is converted into voltage which could be measured automatically.
- ▶ **Principle 2:** Pressure (or pressure variation at a diaphragm) is converted into resistance, which is then converted into voltage. Voltage could be measured automatically.

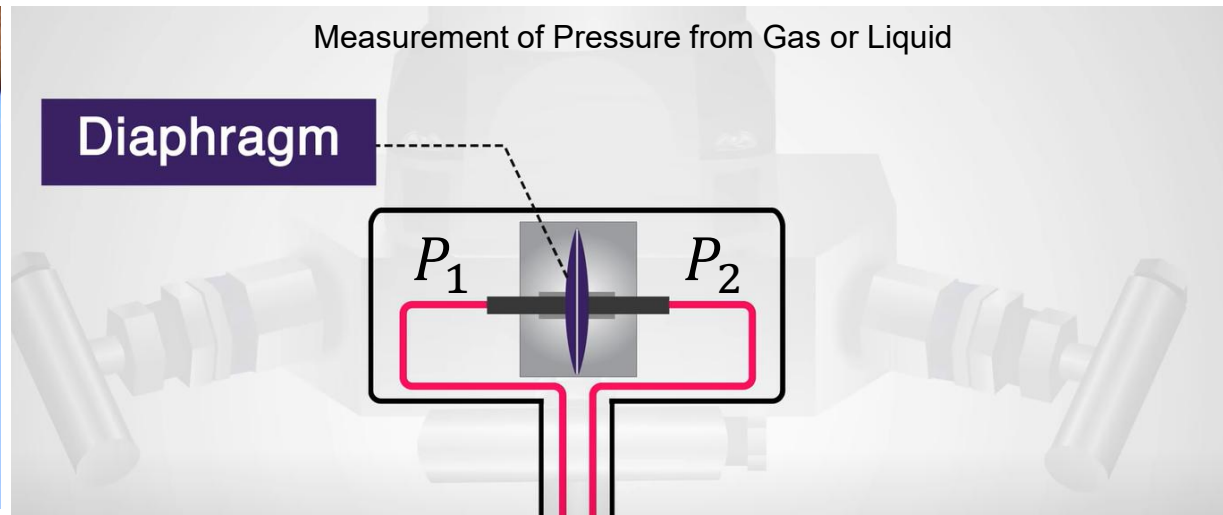
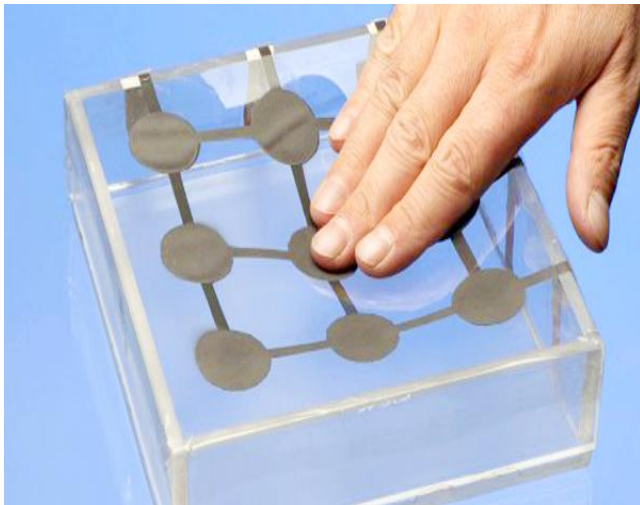

# How to apply principle 1 to design digital measurement and sensing systems for pressure?

- ▶ Pressure is converted to voltage which is measured by digital voltmeter (e.g. microcontrollers).

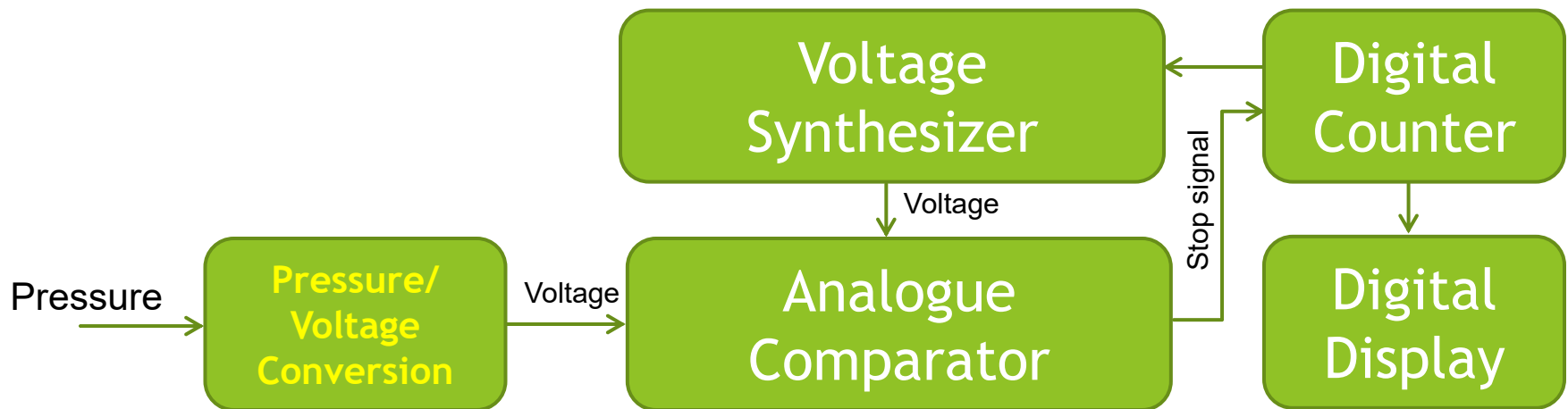

All microcontrollers are programmable digital sensors of voltage!

# How to convert pressure into voltage?

- ▶ Pressure acting on piezo-electrical materials will produce voltage.

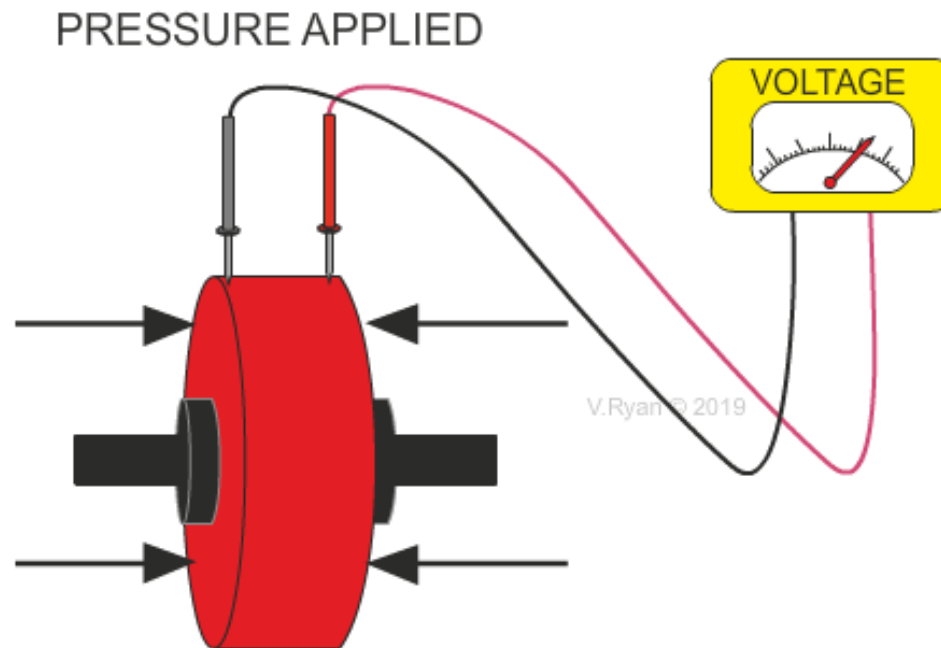

# How to convert pressure into voltage?

- ▶ Pressure acting on piezo-electrical materials will produce voltage.

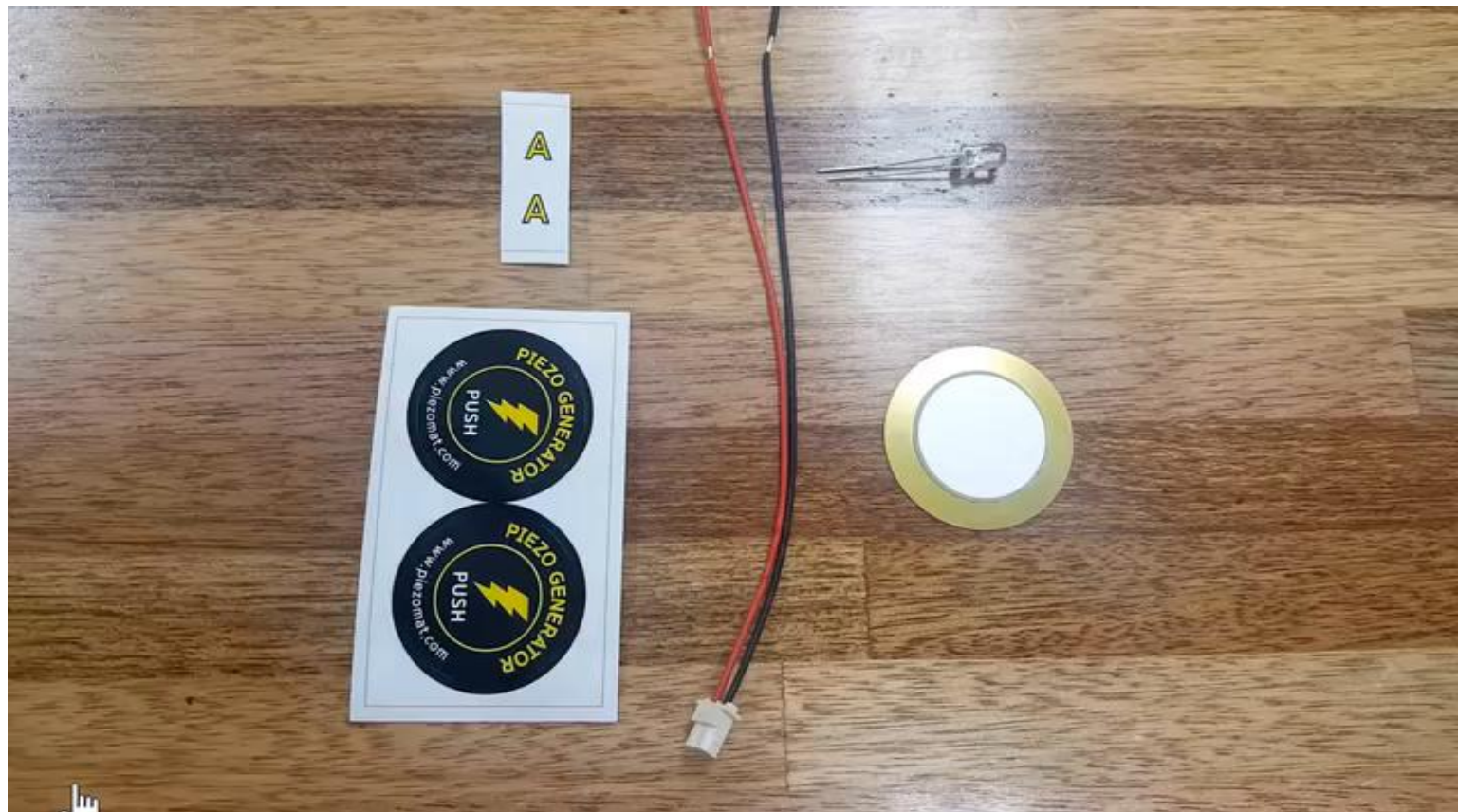

# Comparison of Using Piezo-electric Materials for Sensing Force, Pressure and Acceleration

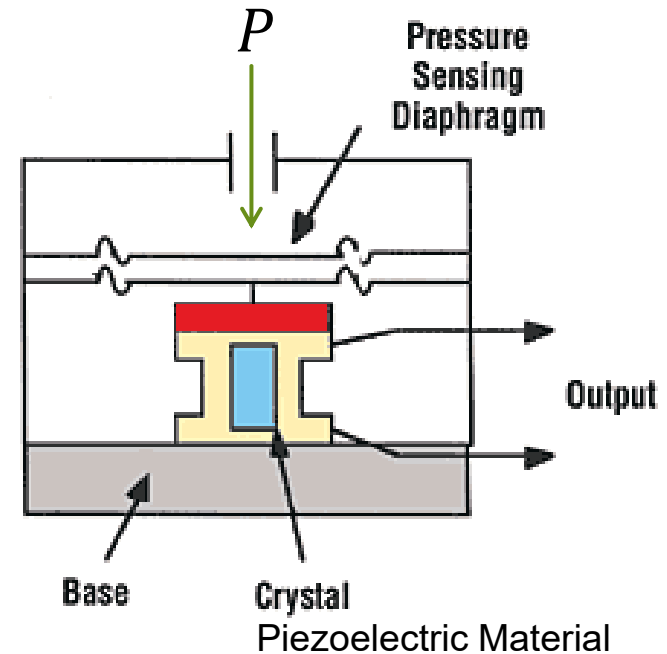

Converted Fore

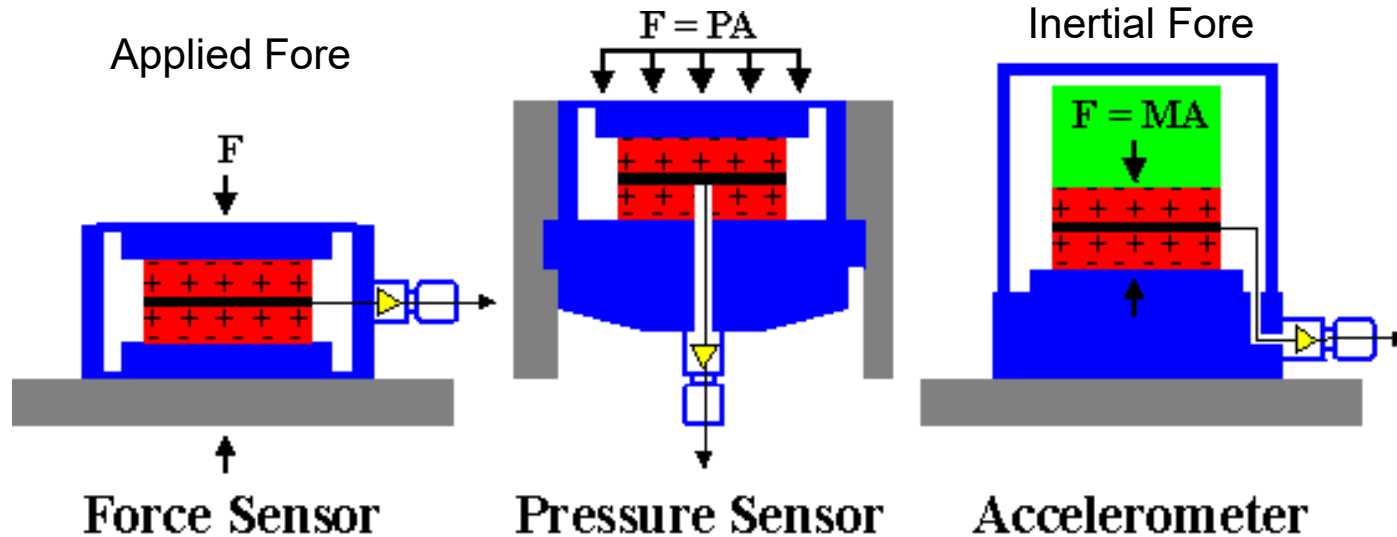

# How to apply principle 2 to design digital measurement and sensing systems for pressure?

- ▶ Pressure is converted to resistance which is then converted to voltage. Finally, the voltage is measured by digital voltmeter (e.g. microcontrollers).

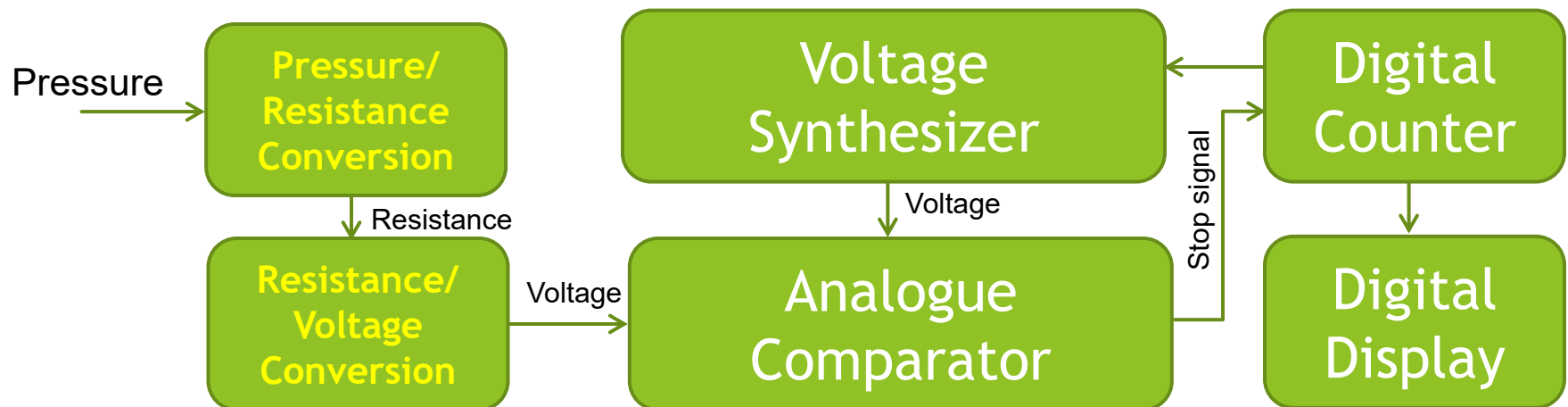

All microcontrollers are programmable digital sensors of voltage!

# Solution 1 of Converting Pressure into Resistance

When pressure increases, radial stress is larger than tangential stress. Hence, the changes of resistance in  $R_1$  and  $R_3$  will be larger than the changes of resistance in  $R_2$  and  $R_4$ .

Such changes in resistance could be converted into changes in voltage with the use of a bridge-circuit.

Pressure Measurement With Strain Gauges on Diaphragm

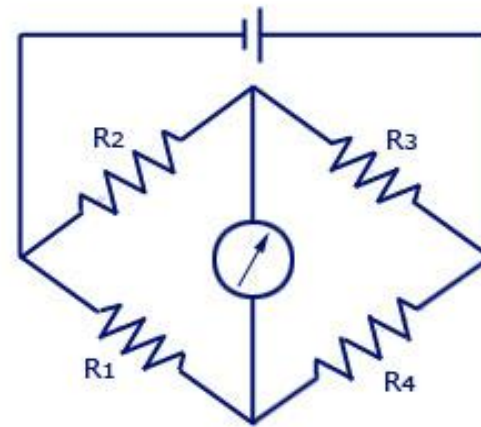
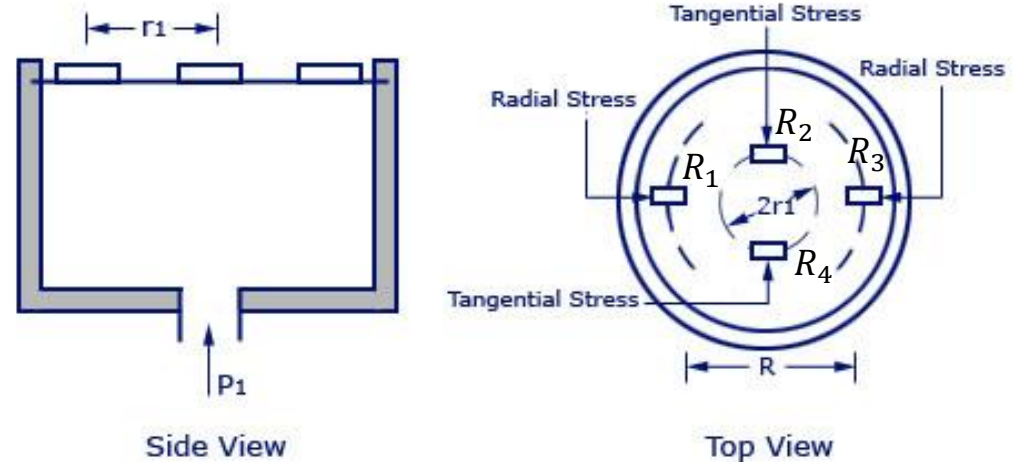

Bridge Circuit

# Solution 2 of Converting Pressure to Resistance

- ▶ When pressure changes, the wiper will change its position. Hence, the resistance value changes. Resistance could then be converted into voltage.

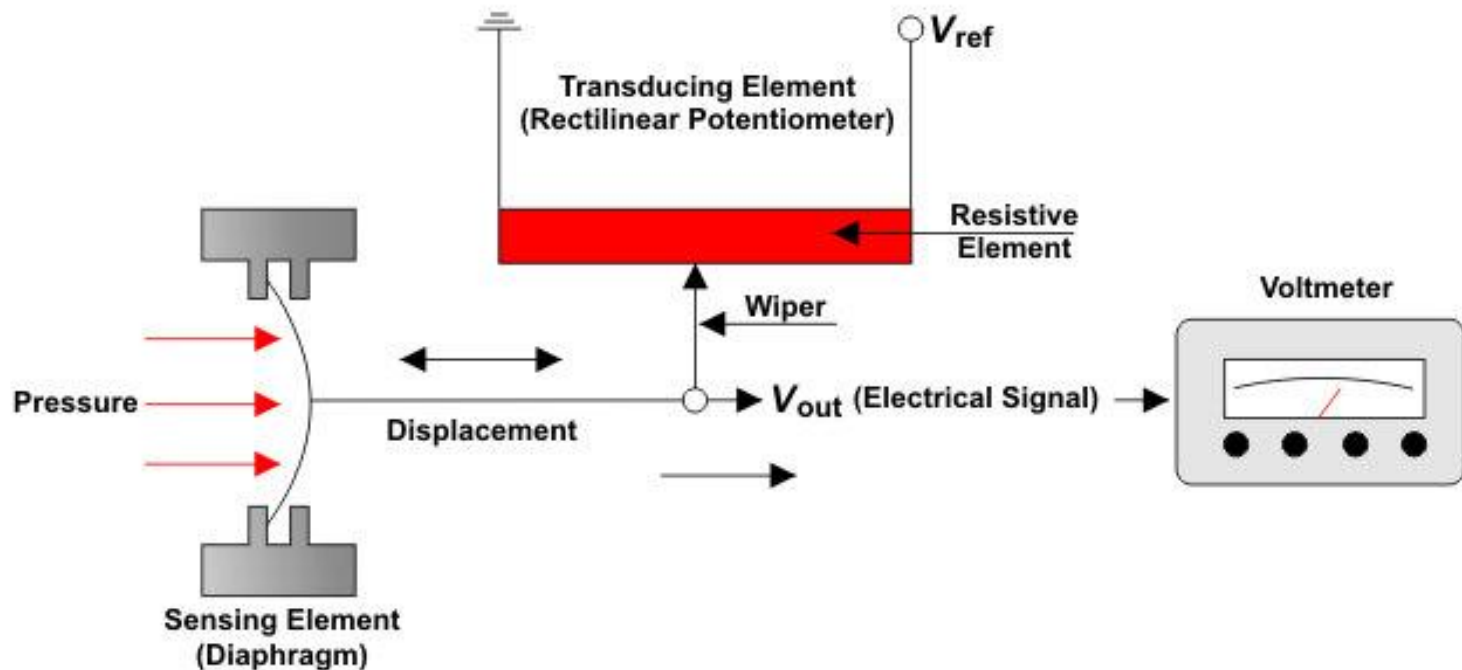

# Solution 3 of Converting Pressure to Resistance

- ▶ Strain gauges are placed on a deformable beam.
- ▶ Pressure difference produces force which acts on the deformable beam.
- ▶ The compression or expansion of strain gauges will make their resistance values to change.
- ▶ Such changes of resistance could be converted into voltage changes.

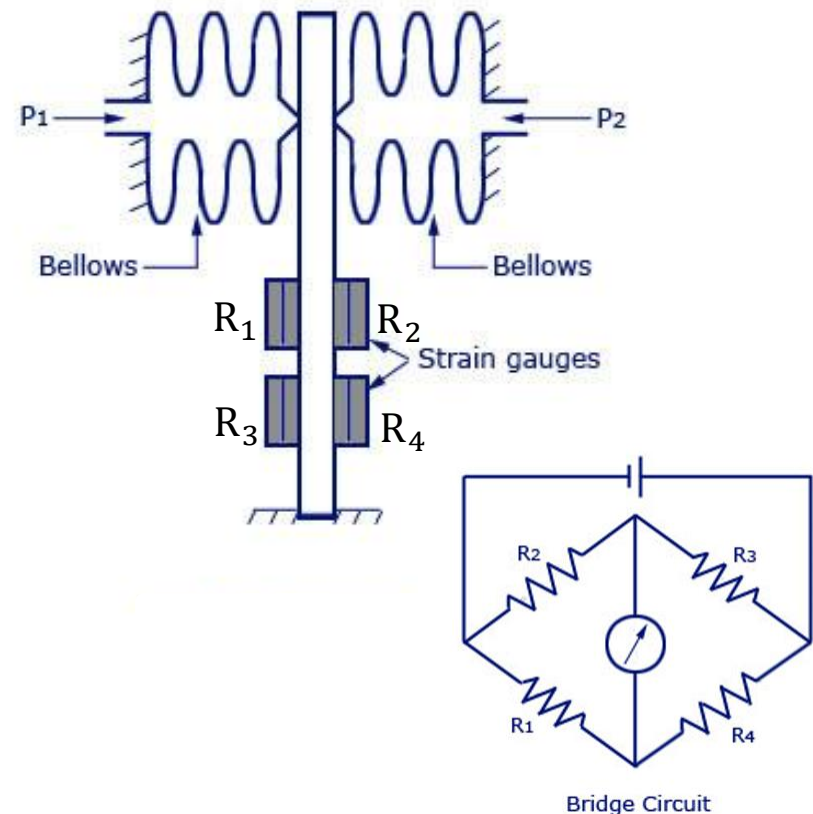

# Other Solution ...

- A matrix of sensing cells.
- Each cell has four strain gauges.
- Pressure is converted into a matrix of resistances.

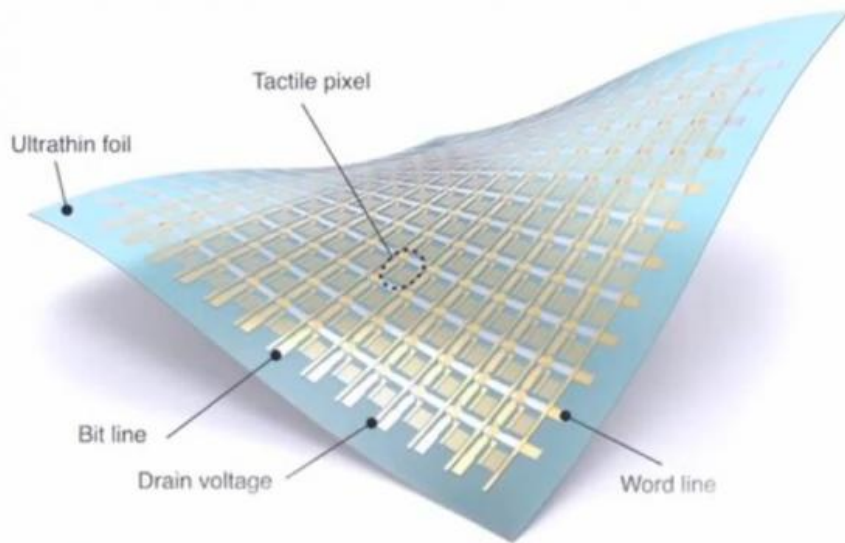
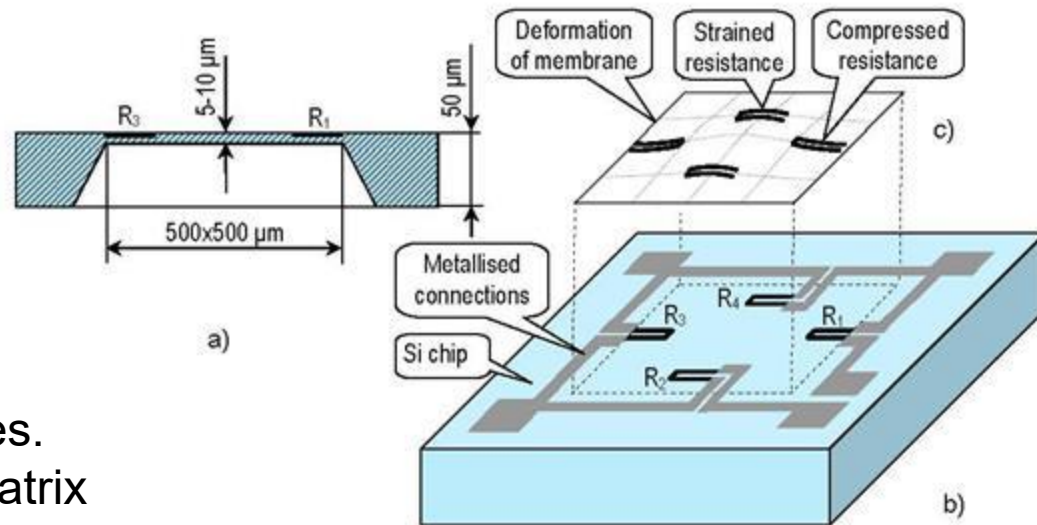

## Other Design Principles ...

- ▶ A plate or diaphragm is placed inside the space of pressure to be measured.
- ▶ Pressure will produce a force on the surface of the plate or diaphragm.
- ▶ The force will make the plate or diaphragm to undertake a displacement.
- ▶ The displacement can be sensed and measured.

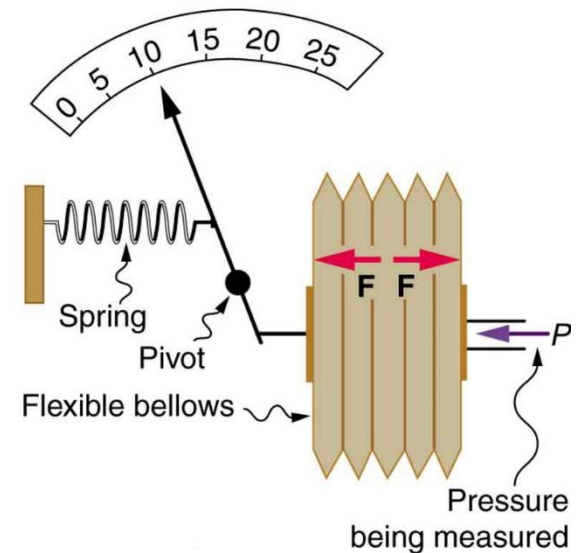
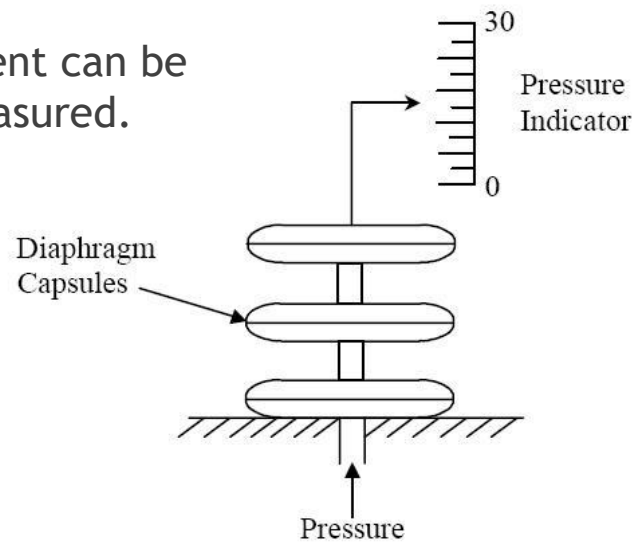
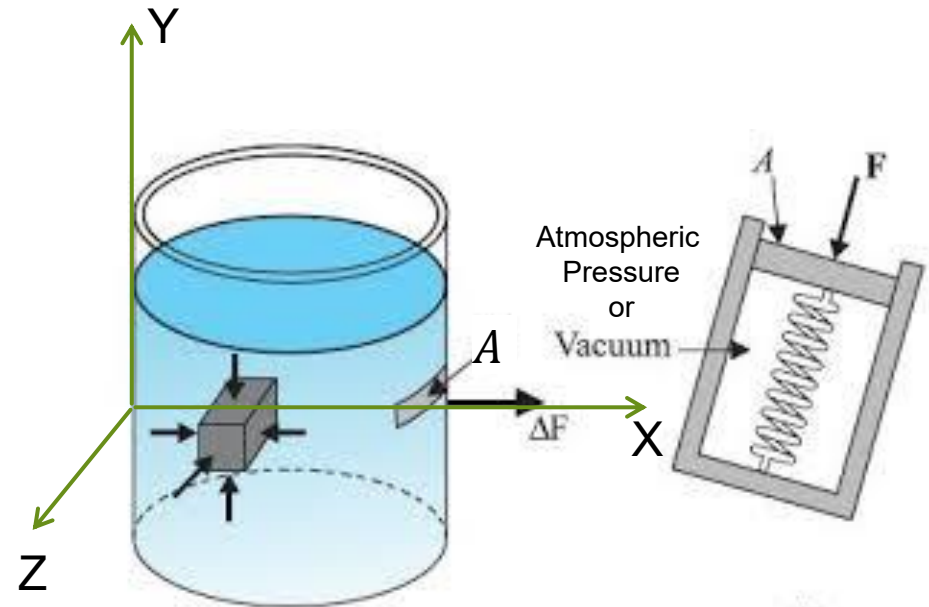

# Remember to Do Calibration

- ▶ Curve fitting for calibration:
  - ▶  $Y_i$  is produced by  $X_i$
  - ▶  $Z_i$  is computed from  $Y_i$
  - ▶  $Z_i$  must be equal to  $X_i$

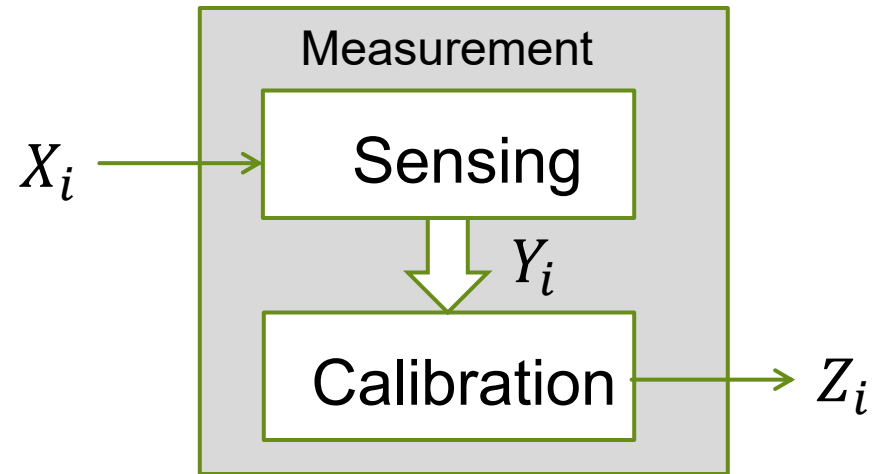

Calibrated Values  $Z_i$

Measured Values  $Y_i$

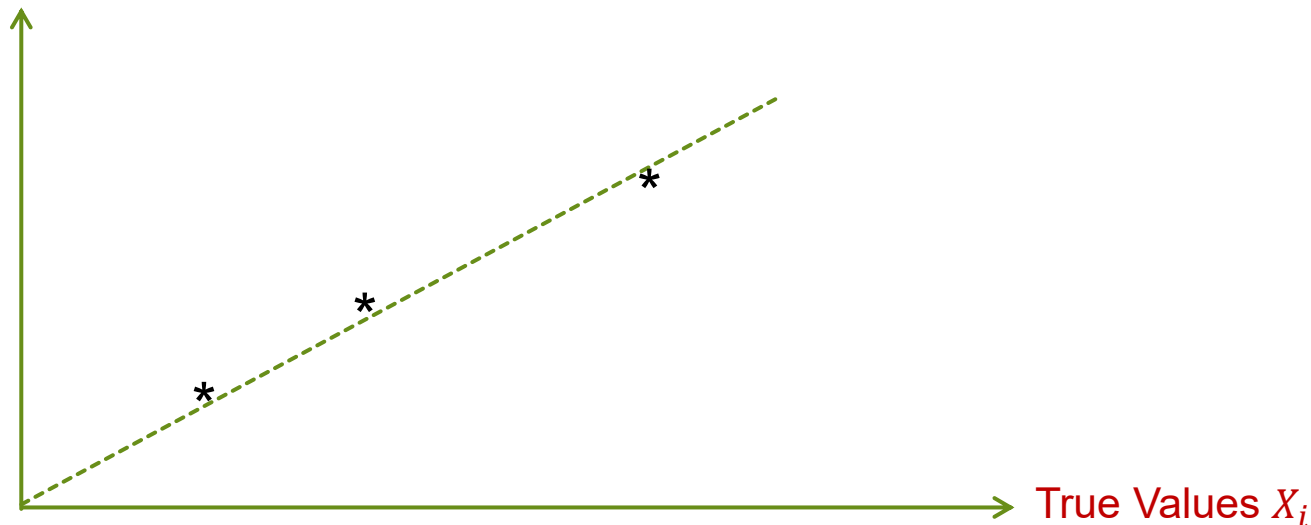

# Remember to Do Error Analysis

- ▶ Systematic error = mean value - true value
- ▶ Repeatability error = value with maximum error - mean value
- ▶ Accuracy = value with minimum error - mean value
- ▶ Hysteresis error = |measured value in increasing - measured value in decreasing|

For each true value, we can do error analysis

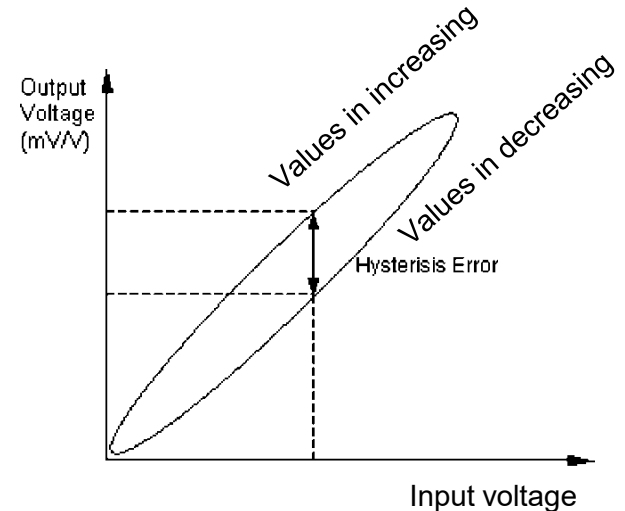
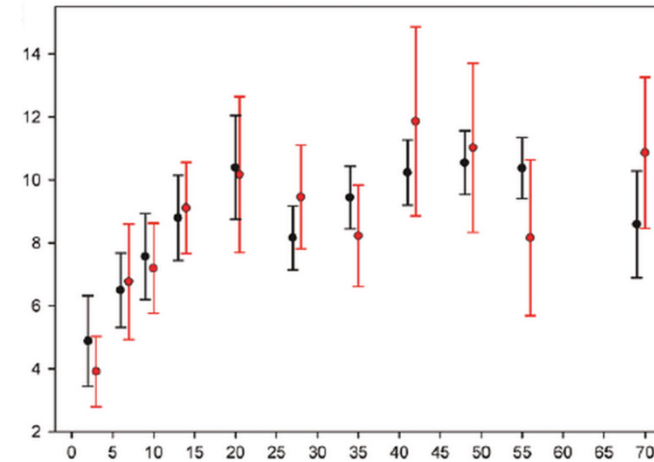

# Summary

- ▶ Understanding of Pressure
- ▶ Computation of Pressure
- ▶ Measurement of Pressure

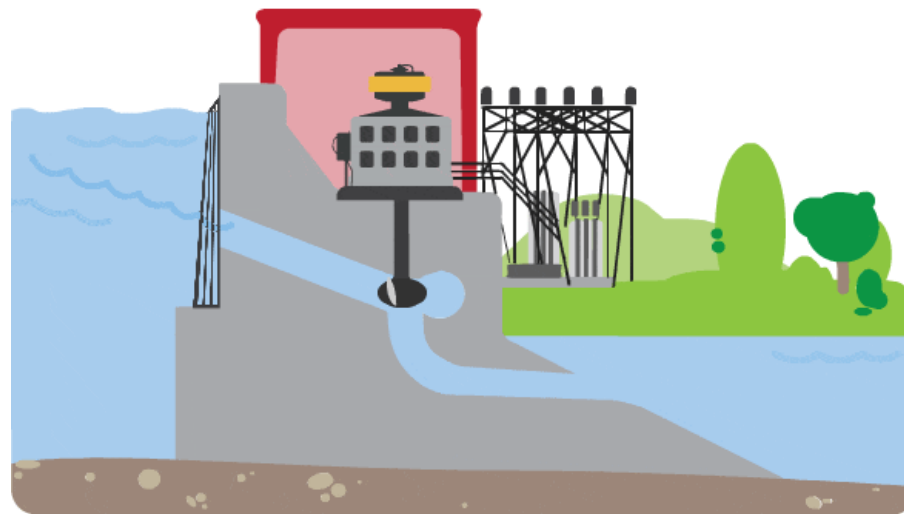

# Outline of Module 4

- ▶ Lecture 1:
  - ▶ Measurement of Pressure
- ▶ Lecture 2:
  - ▶ Measurement of Temperature
- ▶ Lecture 3:
  - ▶ Measurement of Humidity
- ▶ Lecture 4:
  - ▶ Measurement of Vibration
- ▶ Lecture 5:
  - ▶ Measurement of Air Quality

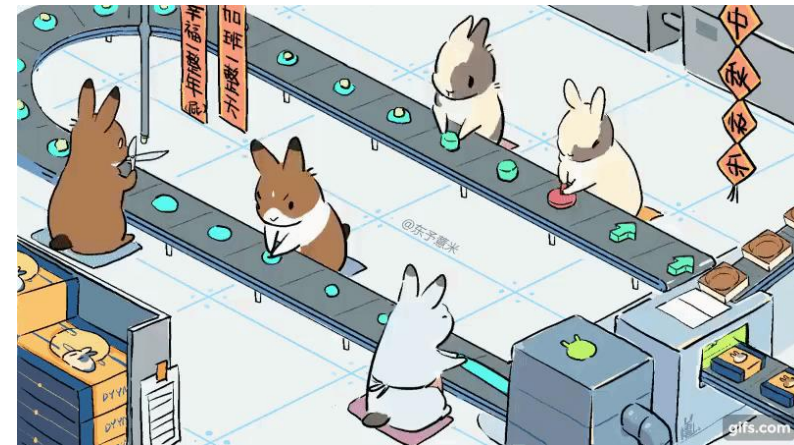



**NANYANG  
TECHNOLOGICAL  
UNIVERSITY**

**School of Mechanical & Aerospace Engineering**

Design, Machine, Control, Intelligence

Module 4 Lecture 2

MA4822

# Measurement of Temperature

Xie Ming, PhD (France)

[mmxie@ntu.edu.sg](mailto:mmxie@ntu.edu.sg)

<http://personal.ntu.edu.sg/mmxie>

# Outline

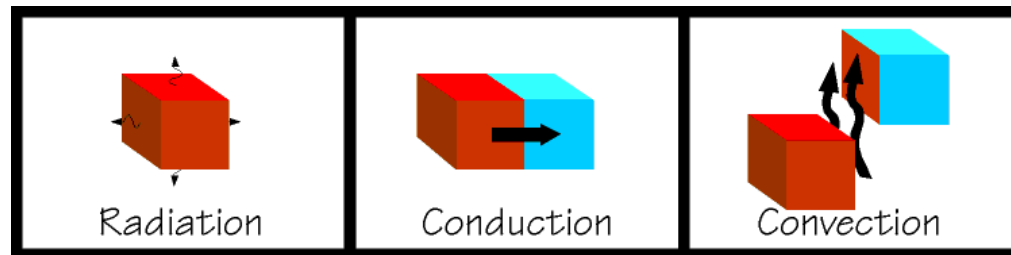

► Understanding of Temperature

► Computation of Temperature

► Measurement of Temperature

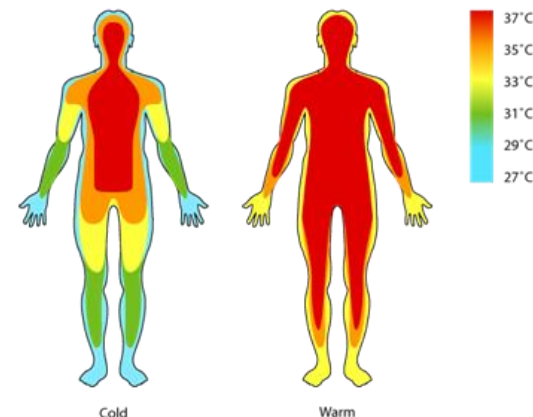
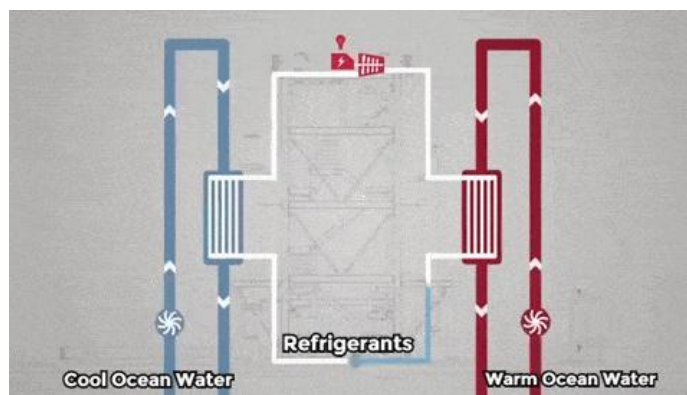
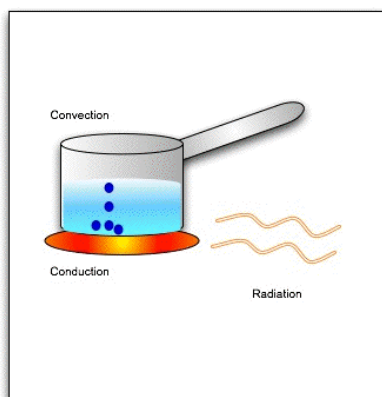
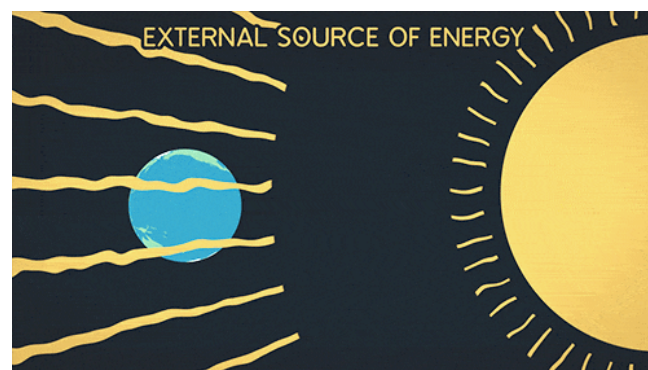

# Outline

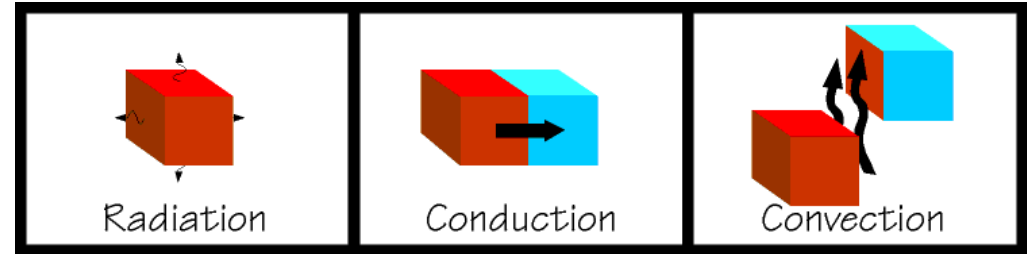

► Understanding of Temperature

► Computation of Temperature

► Measurement of Temperature

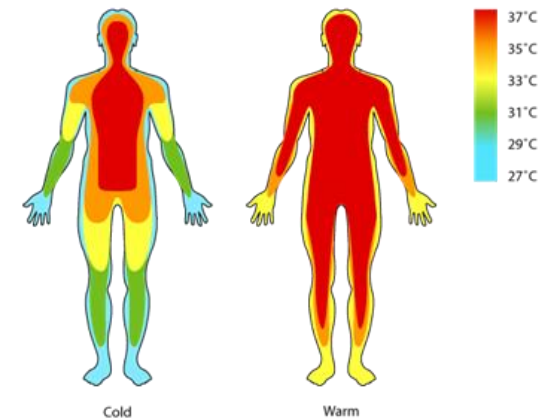
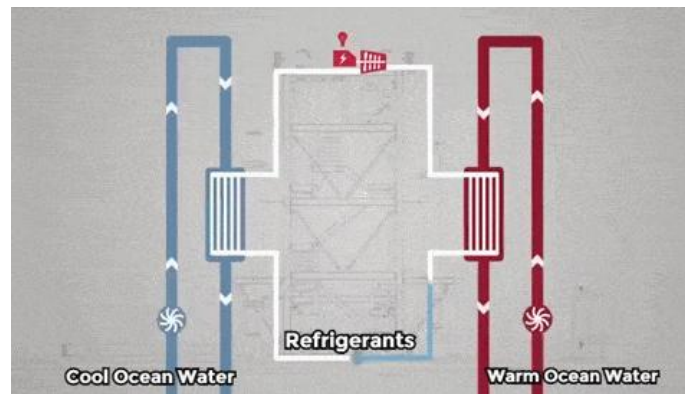
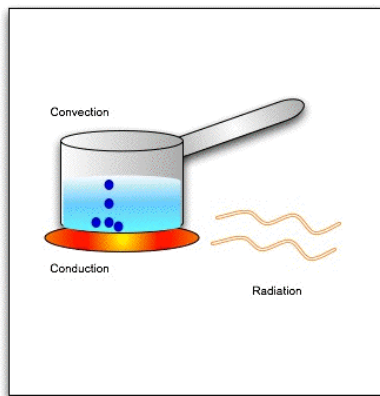
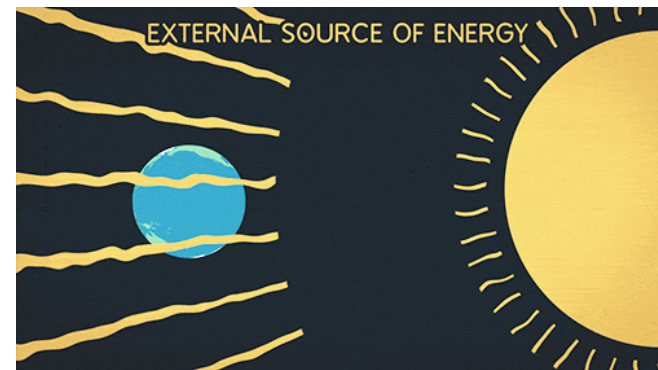

# Three Types of Popular Energies

- ▶ Electrical Energy
  - ▶ Voltage
  - ▶ Current
- ▶ Mechanical Energy
  - ▶ Force
  - ▶ Velocity
- ▶ Thermal Energy (or Heat)
  - ▶ **Temperature**
  - ▶ Flowrate of heat

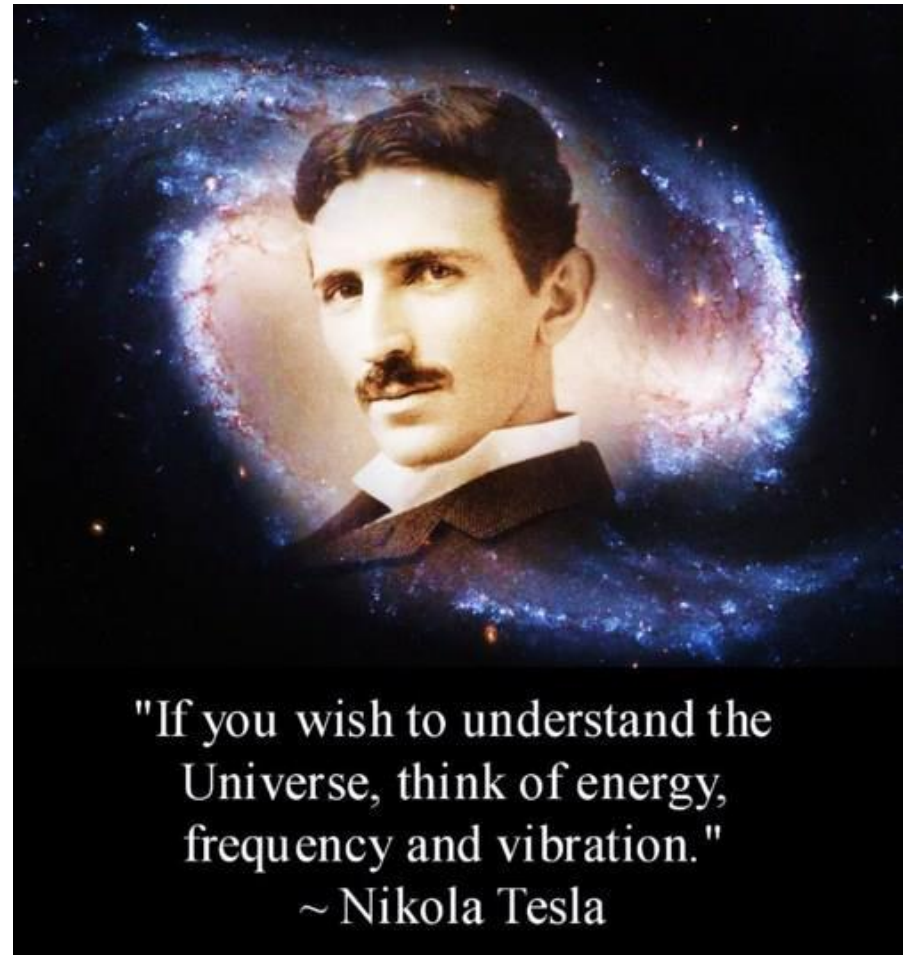

# Understanding Thermal Energy (1)

- ▶ Heat is *something which may be transferred from one body to another*.
- ▶ Heat is a *measurable quantity*, and can be described mathematically.

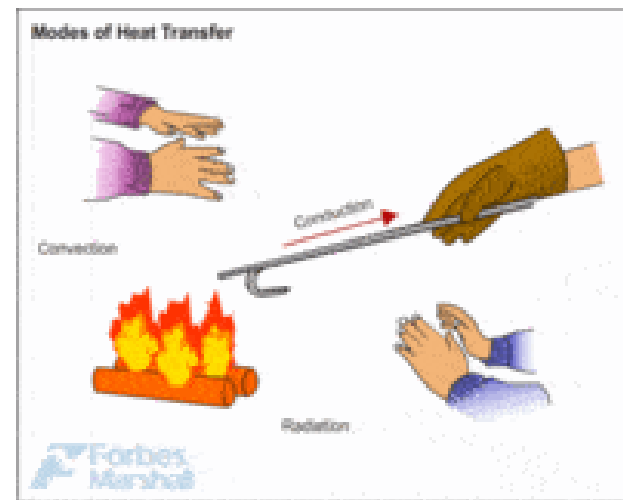
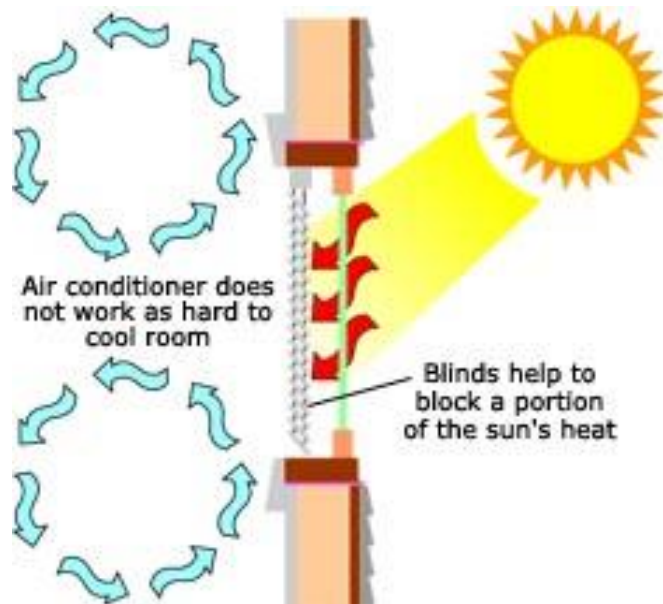

# Understanding Thermal Energy (2)

- ▶ Heat *cannot be treated as a material substance*, because it may be transformed into something that is not a material substance, e.g., mechanical work.

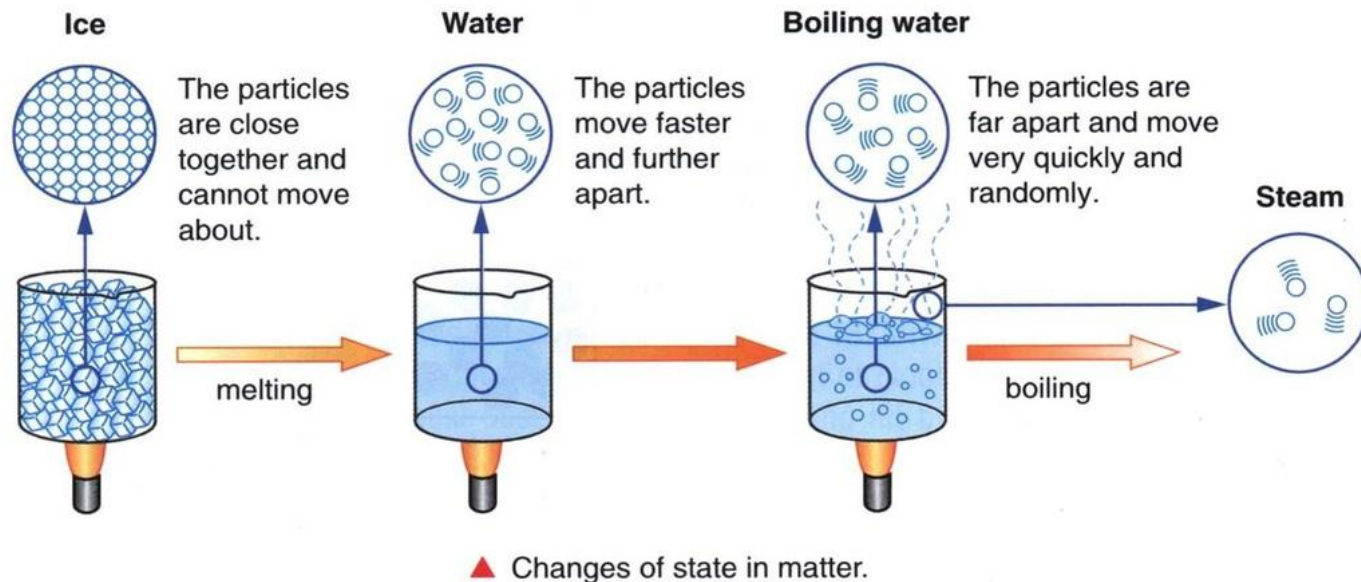

# Understanding Thermal Energy (3)

- ▶ Heat is a layman term which refers to thermal energy.

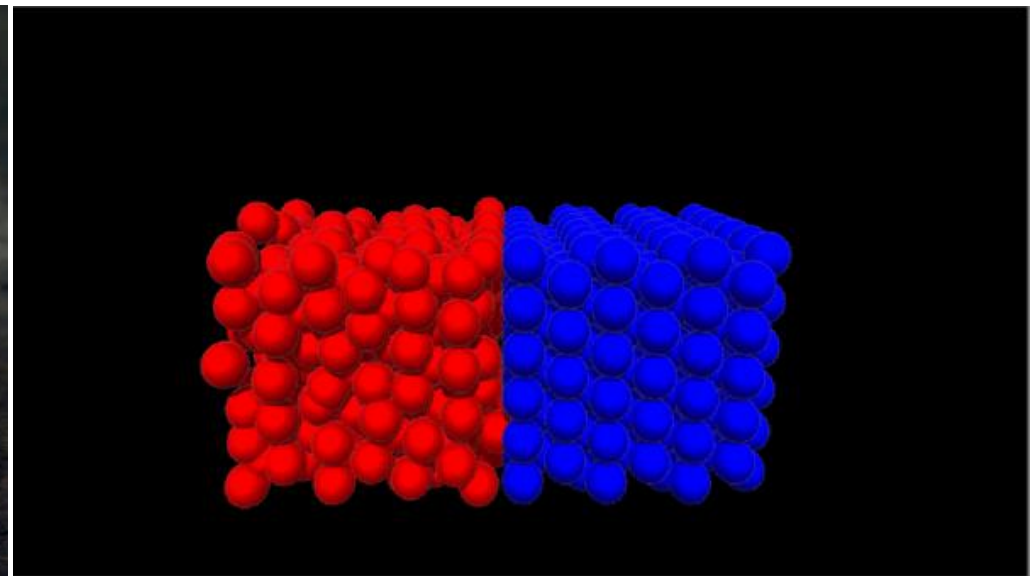



# Applications of Thermal Energy

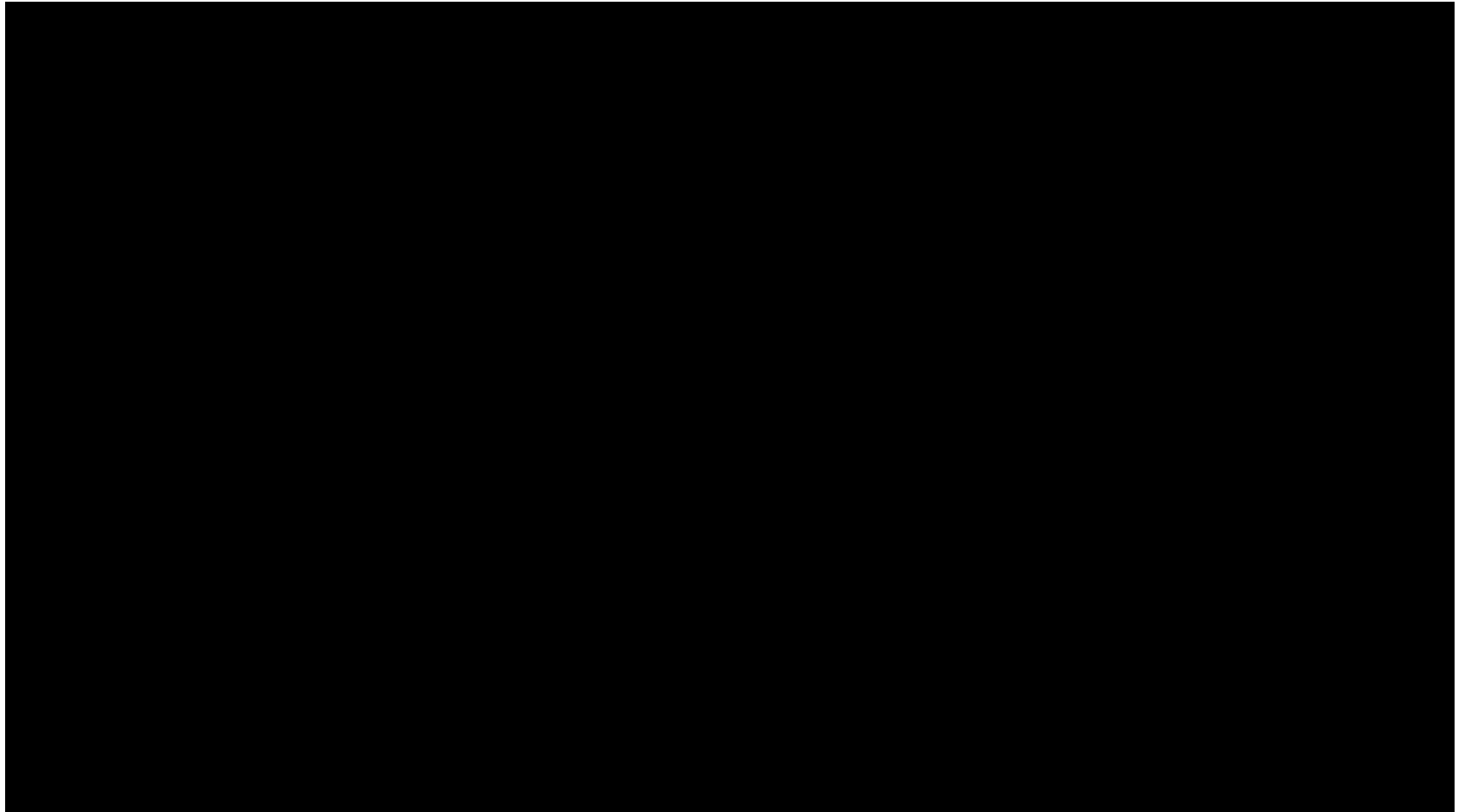

# Understanding Temperature (1)

- ▶ Temperature creates the sensation of hotness or coldness.
- ▶ There are two natural references for zero temperature.

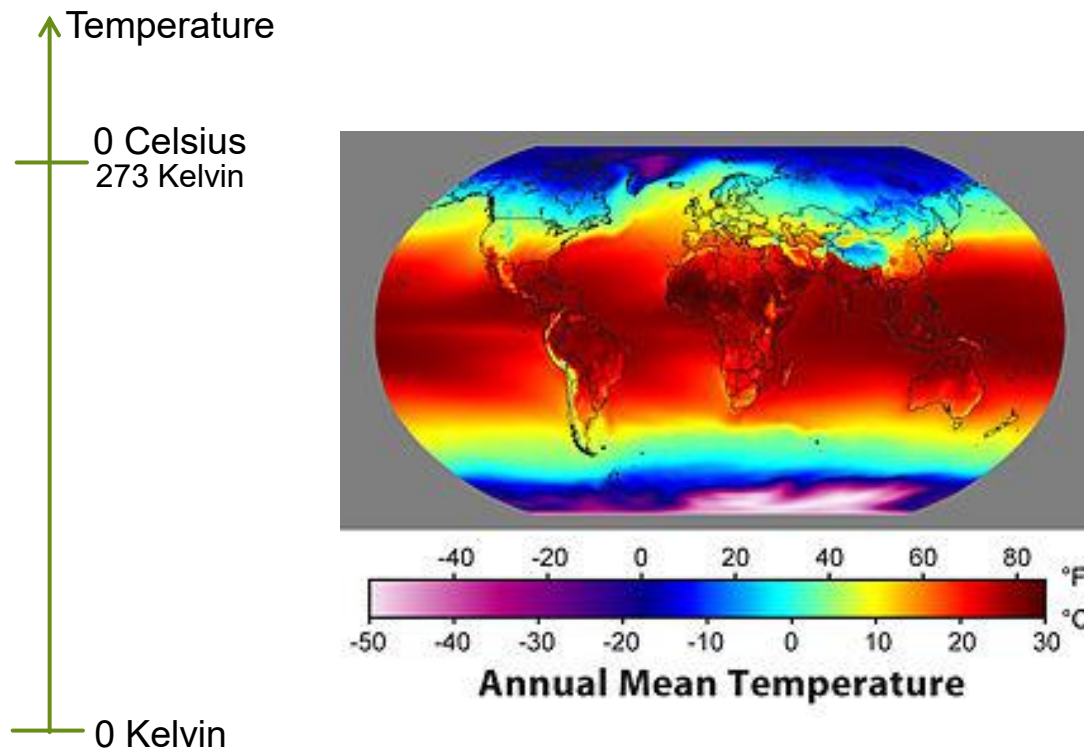

SI Scale:	Celsius
Kelvin Scale:	K
US Scale:	Fahrenheit

$$^{\circ}\text{F} = ^{\circ}\text{C} \times 9/5 + 32$$

$$\text{K} = ^{\circ}\text{C} + 273.15$$

# Units of Measurement of Temperature

	from Celsius	to Celsius
<b>Fahrenheit</b>	$[^{\circ}\text{F}] = [^{\circ}\text{C}] \times \frac{9}{5} + 32$	$[^{\circ}\text{C}] = ([^{\circ}\text{F}] - 32) \times \frac{5}{9}$
<b>Kelvin</b>	$[\text{K}] = [^{\circ}\text{C}] + 273.15$	$[^{\circ}\text{C}] = [\text{K}] - 273.15$
<b>Rankine</b>	$[^{\circ}\text{R}] = ([^{\circ}\text{C}] + 273.15) \times \frac{9}{5}$	$[^{\circ}\text{C}] = ([^{\circ}\text{R}] - 491.67) \times \frac{5}{9}$
<b>Delisle</b>	$[^{\circ}\text{De}] = (100 - [^{\circ}\text{C}]) \times \frac{3}{2}$	$[^{\circ}\text{C}] = 100 - [^{\circ}\text{De}] \times \frac{2}{3}$
<b>Newton</b>	$[^{\circ}\text{N}] = [^{\circ}\text{C}] \times \frac{33}{100}$	$[^{\circ}\text{C}] = [^{\circ}\text{N}] \times \frac{100}{33}$
<b>Réaumur</b>	$[^{\circ}\text{Ré}] = [^{\circ}\text{C}] \times \frac{4}{5}$	$[^{\circ}\text{C}] = [^{\circ}\text{Ré}] \times \frac{5}{4}$
<b>Rømer</b>	$[^{\circ}\text{Rø}] = [^{\circ}\text{C}] \times \frac{21}{40} + 7.5$	$[^{\circ}\text{C}] = ([^{\circ}\text{Rø}] - 7.5) \times \frac{40}{21}$

Basic Unit of Measurement

# Understanding Temperature (2)

- Temperature is the manifestation of kinetic energy at atomic level.

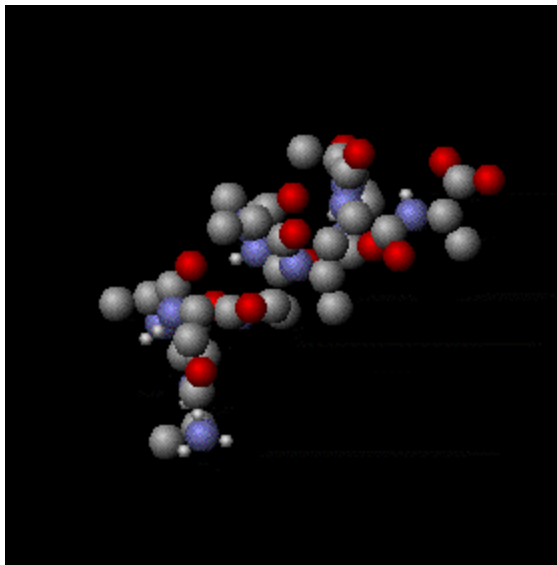

$$E_{K,x} = \frac{1}{2} K_B T$$

$$E_{K,y} = \frac{1}{2} K_B T$$

$$E_{K,z} = \frac{1}{2} K_B T$$

$$E_K = \frac{3}{2} K_B T$$

# Understanding Temperature (3)

- Temperature represents the potential of heat.

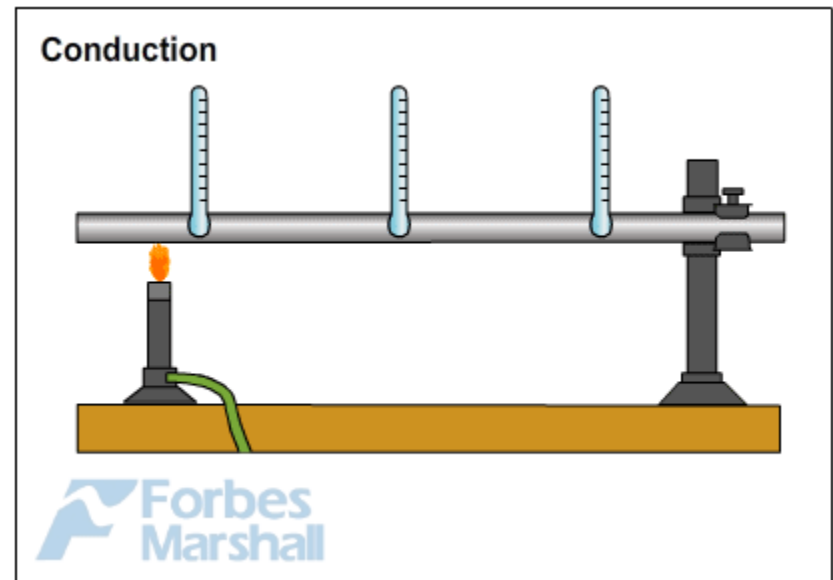
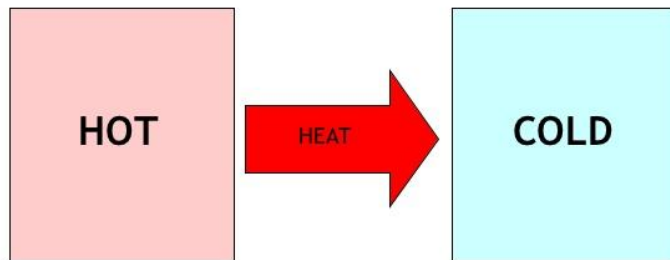

# Understanding Temperature (4)

- ▶ The difference of temperature will cause the transfer of heat or flow of heat.

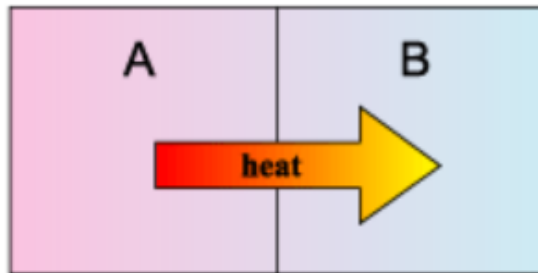

# There Are Three Types of Heat Transfer

► Conduction

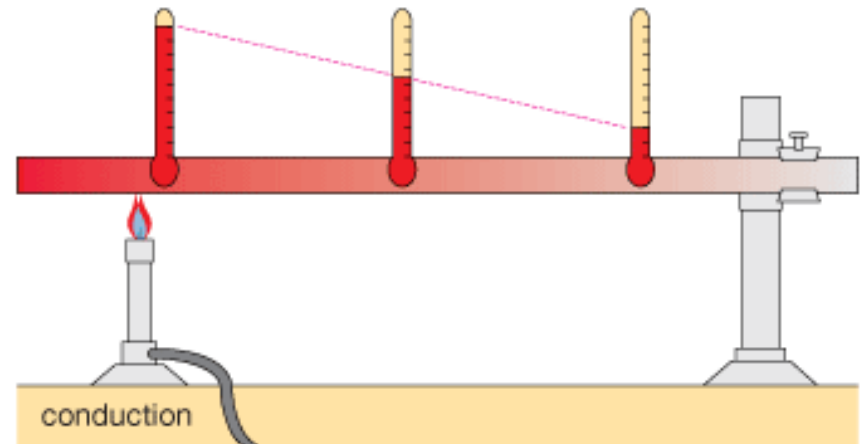

► Convection

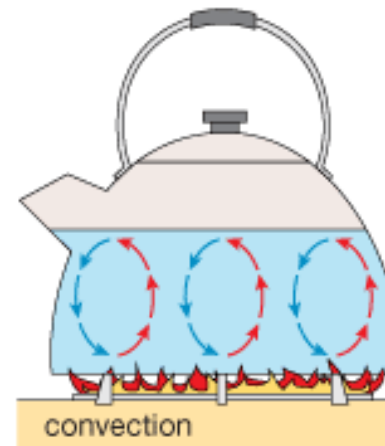

► Radiation

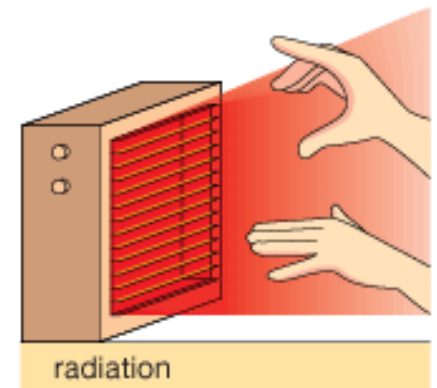

# Example of Heat Transfer Within and Outside Rigid Body

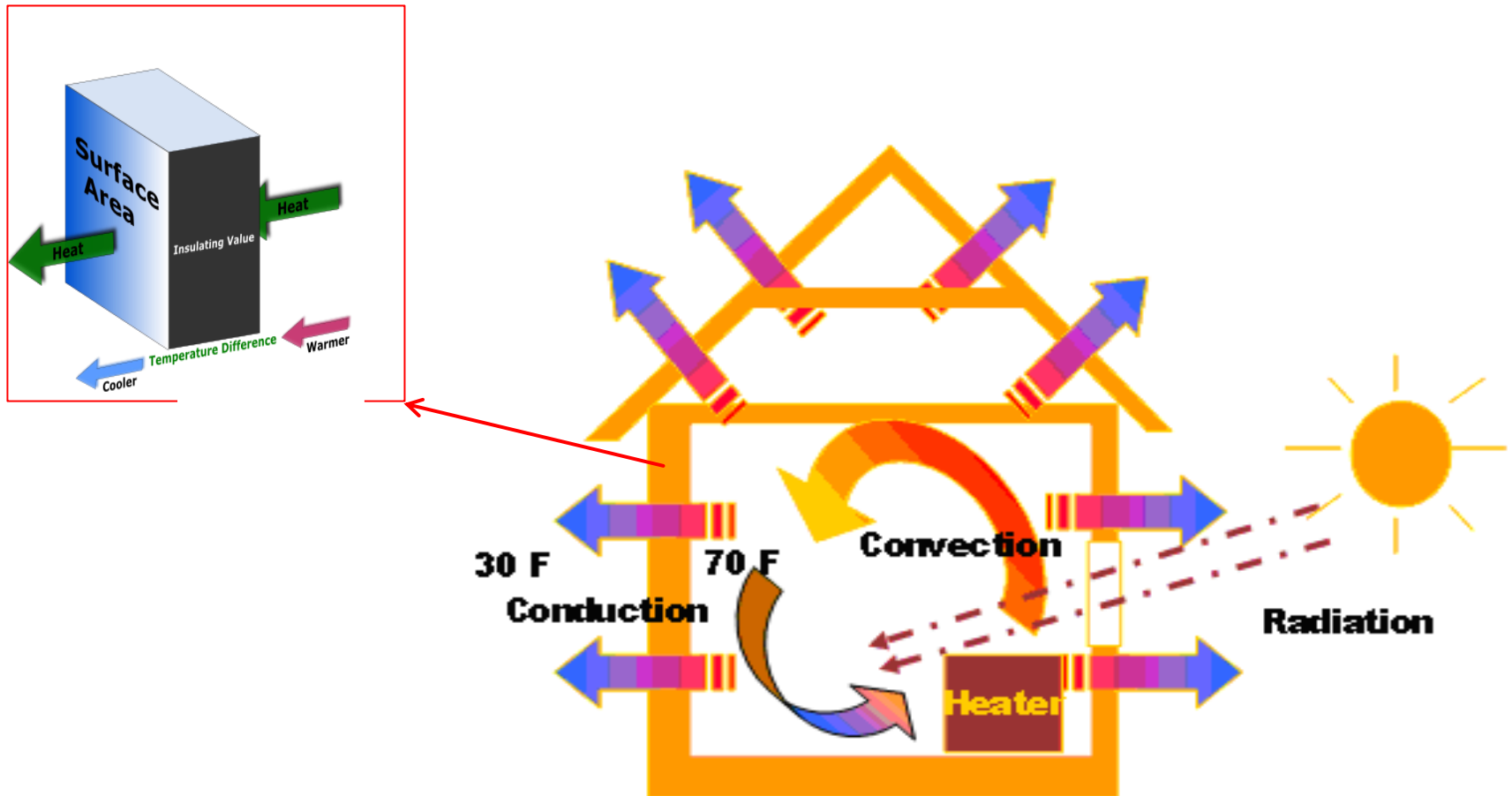

# Example of Heat Transfer Caused by Temperature Difference

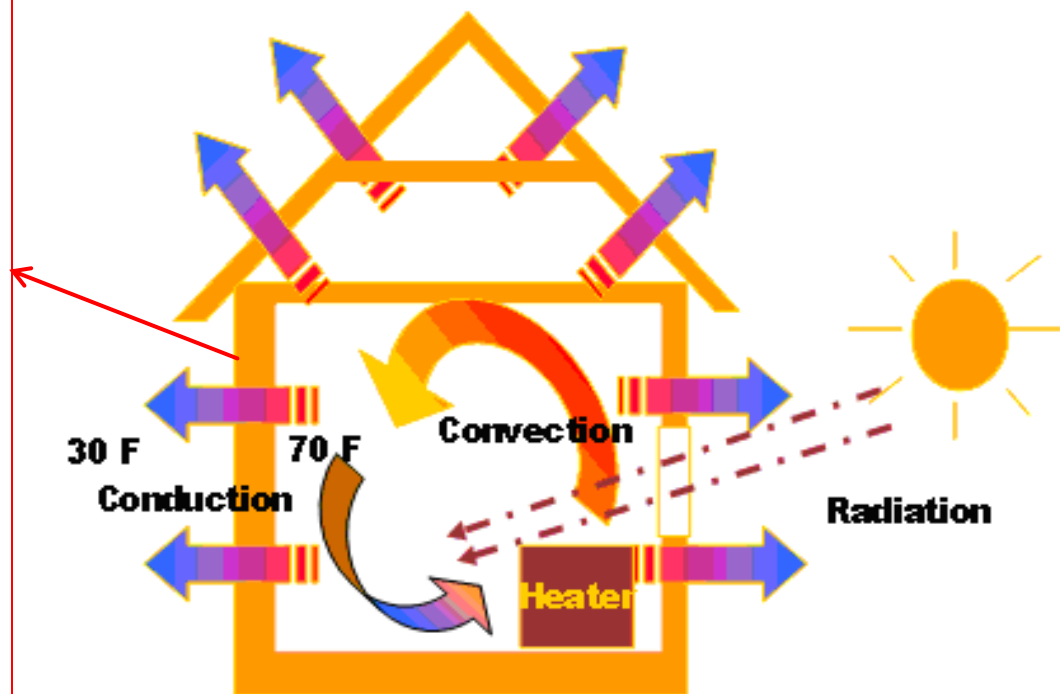
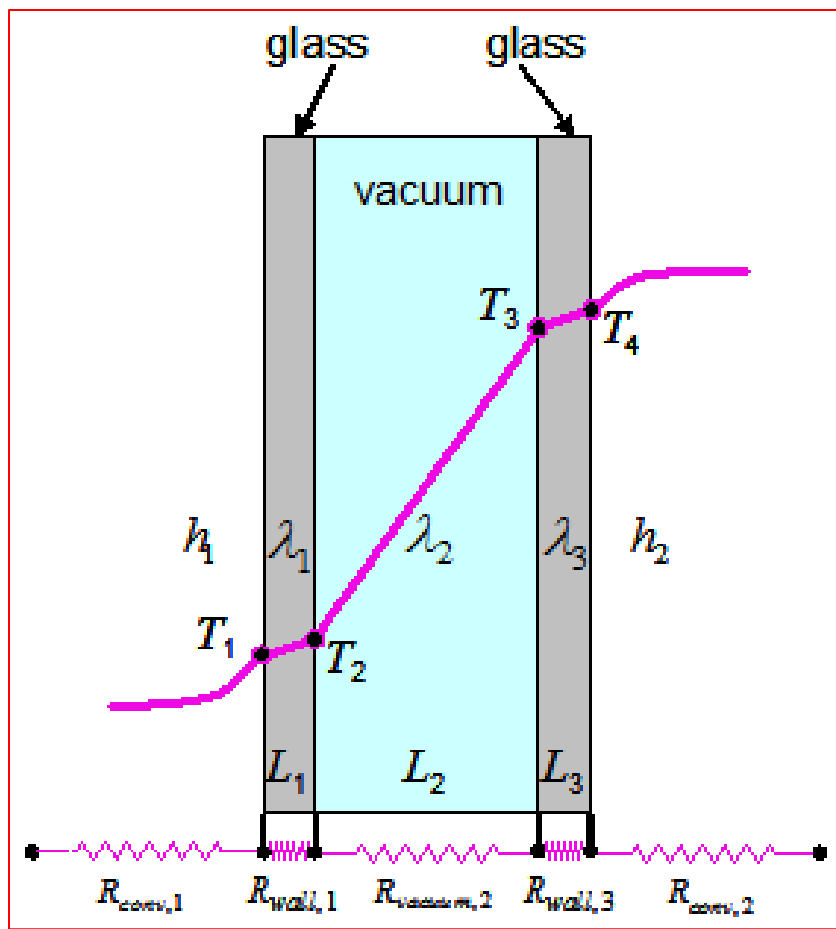

# Understanding Temperature (5)

- The change of temperature can cause linear expansion of materials.

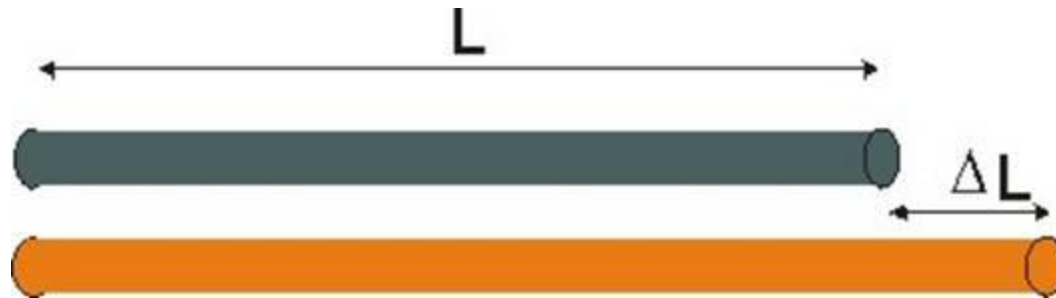

$$\Delta L = \alpha L_0 \Delta T$$

# Understanding Temperature (6)

- The change of temperature can cause volume expansion of materials.

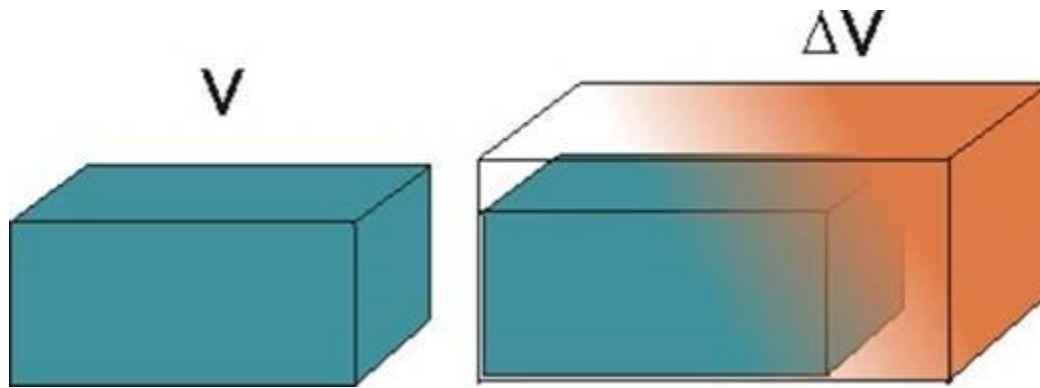

$$\Delta V = \beta V_0 \Delta T$$

What are the useful equations related to temperature?

# Outline

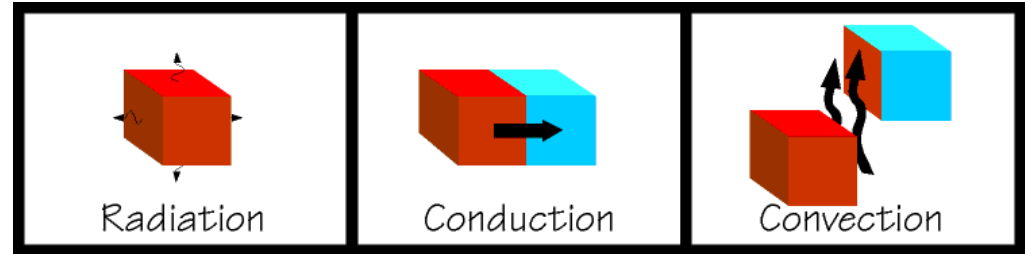

- ▶ Understanding of Temperature
- ▶ Computation of Temperature
- ▶ Measurement of Temperature

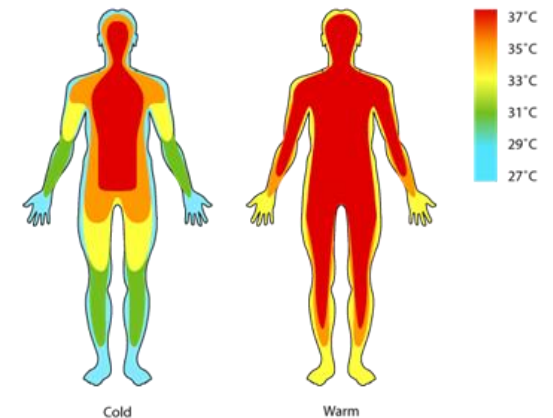
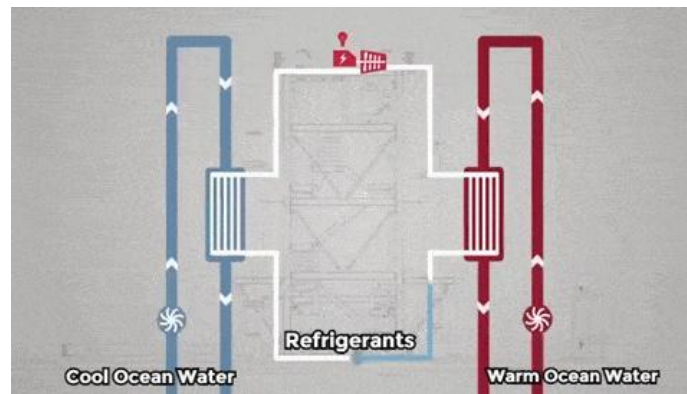
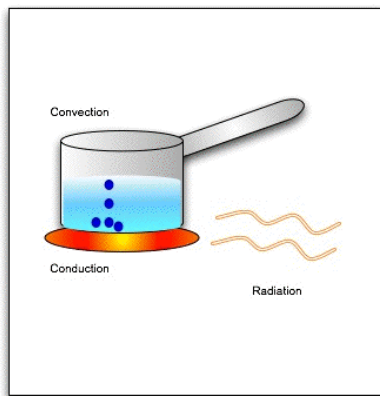
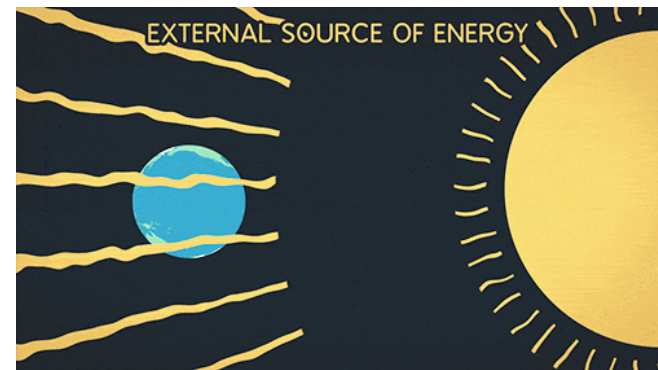

# Useful Equation of Temperature (1)

- Equation of Ideal Gas, which is a function of temperature.

$$PV = nRT$$

Pressure

Temperature

Number of moles

Volume

Gas constant

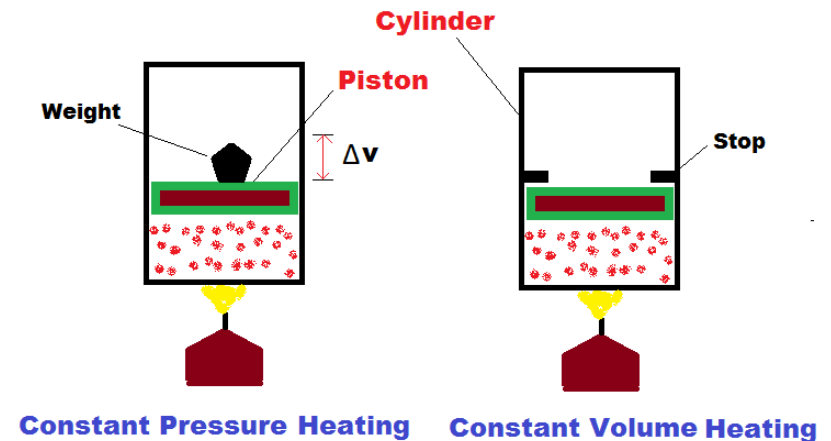

# Example

- ▶ As shown in the figure, what is the temperature of the gas when the volume is 44.8 litres?

- ▶ Answer:

$$T = \frac{PV}{nR}$$

$$T = \frac{1.0 \times 44.8}{2 \times 0.0821} = 272.838K$$

$$T = -0.312^{\circ}C$$

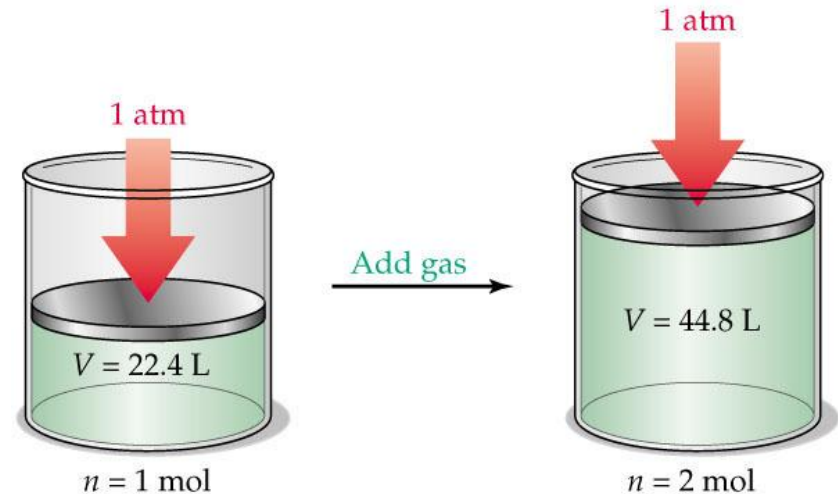

# Useful Equation of Temperature (2)

- Equation of Internal Thermal Energy, which is the amount of heat in order to cause intended change in temperature.

$$Q = cm\Delta T$$

heat added
specific heat
mass
change in temperature

$$\begin{array}{c}
 \text{J} \longrightarrow Q = m \times C \times \Delta T \longleftarrow \text{K} \\
 \nearrow \text{g} \qquad \nwarrow \frac{\text{J}}{\text{g}\cdot\text{K}}
 \end{array}$$

## Example

- ▶ A pan contains 1.5 kg of water at 20.0 degrees Celsius. It is placed on a stove. The specific heat capacity of water is 4190 J/kg.K. During the process of boiling the water, the water absorbs the heat at the rate of 500 J/s. What is the temperature of the water 1.0 minute later?

- ▶ Answer:

$$Q = mc(T - 20.0)$$

$$T = \frac{Q}{mc} + 20.0 = \frac{500 \times 60}{1.5 \times 4190} + 20.0$$

$$T = 24.77^\circ\text{C}$$

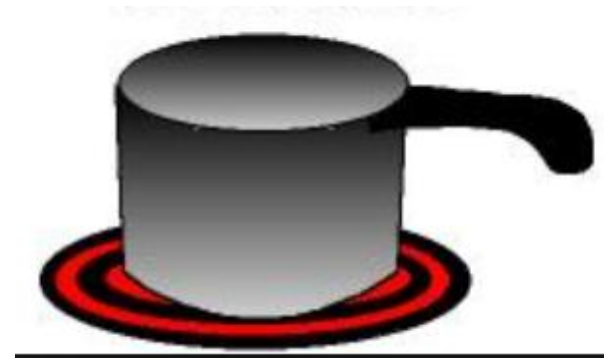

# Useful Equation of Temperature (3)

- Equation of Conduction, which describes heat transfer inside or among interfaced solids

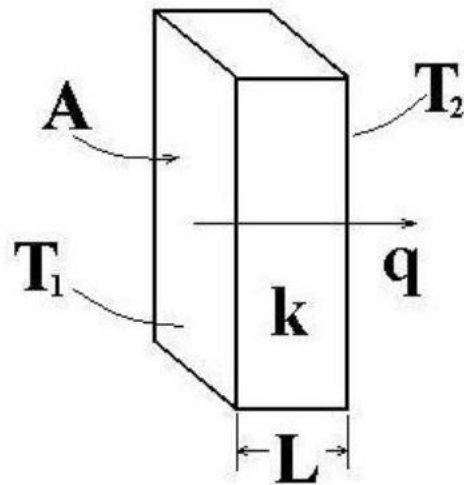

$$q = \frac{dQ}{dt} = k A \frac{T_1 - T_2}{L}$$

Thermal conductivity coefficient

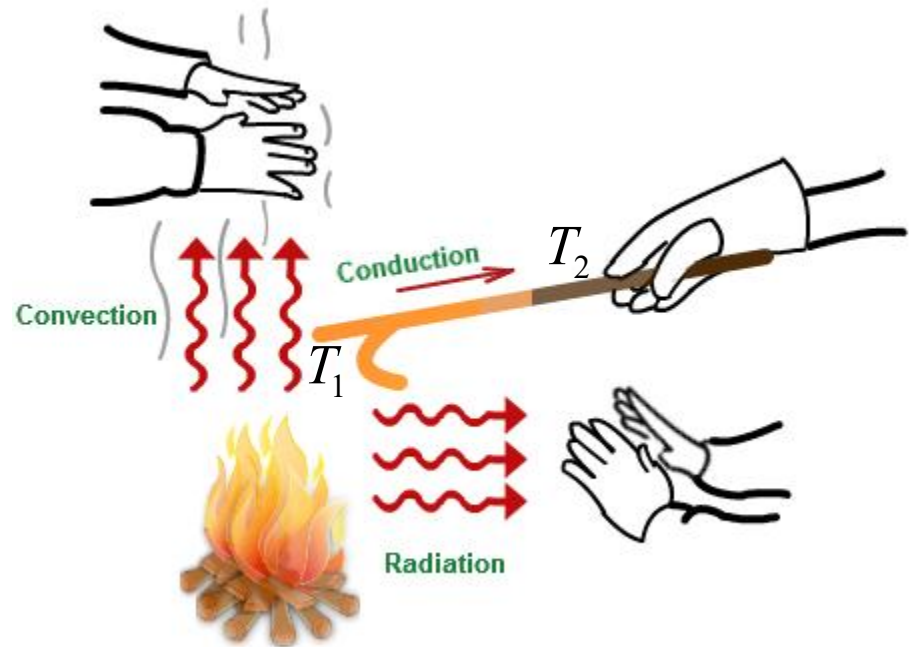

# Example

- ▶ A room's temperature is held at 26.0 degrees Celsius. Assume that the thickness of the wall is 20.0 cm. And, its thermal conductivity is 0.19W/m.K. If the energy consumption of the wall is 50.0 W/m<sup>2</sup>, what is the temperature outside the wall?
- ▶ Answer:

$$\frac{1}{A} \frac{dQ}{dt} = 50.0 \text{ W} / \text{m}^2 = k \frac{(T_1 - T_2)}{L}$$

$$T_2 = T_1 - \frac{50.0 \times L}{k} = 26.0 - \frac{50.0 \times 0.2}{0.19}$$

$$T_2 = -26.63^\circ \text{C}$$

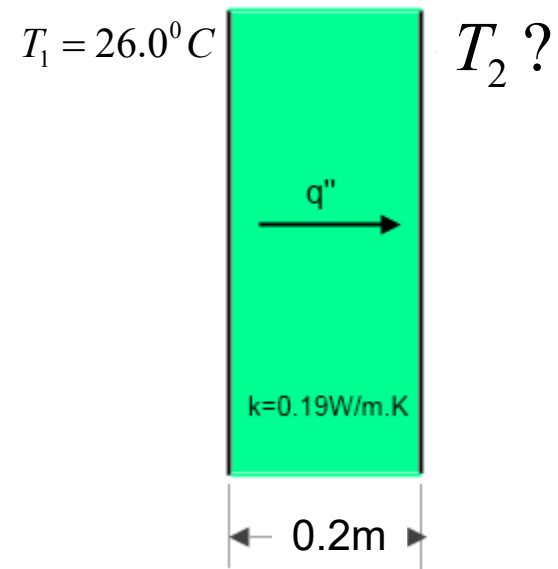

# Example

- ▶ A steel bar of 20.0 cm long is welded end-to-end to a copper bar of 20.0 cm long. The cross-section's areas of the two bars are the same. The thermal conductivity of steel is  $50.2 \times 10^3 \text{ W/m.K}$  while the thermal conductivity of copper is  $385.0 \times 10^3 \text{ W/m.K}$ . Assume that the free end of the steel bar is maintained at  $100.0 \text{ }^\circ\text{C}$  while the free end of the copper bar is maintained at  $0.0 \text{ }^\circ\text{C}$ . What is the temperature at the junction of the two bars?
- ▶ Answer:

$$k_{steel} A \frac{100.0 - T}{L_{steel}} = k_{copper} A \frac{T - 0.0}{L_{copper}} \qquad T = \frac{100.0 \times k_{steel}}{k_{steel} + k_{copper}}$$

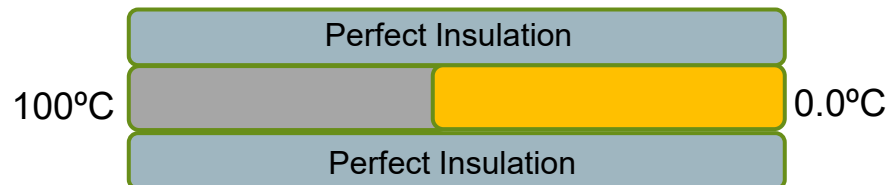

$$T = 11.535^\circ \text{C}$$

# Useful Equation of Temperature (4)

- Equation of Convection, which describes heat transfer between solid and gas

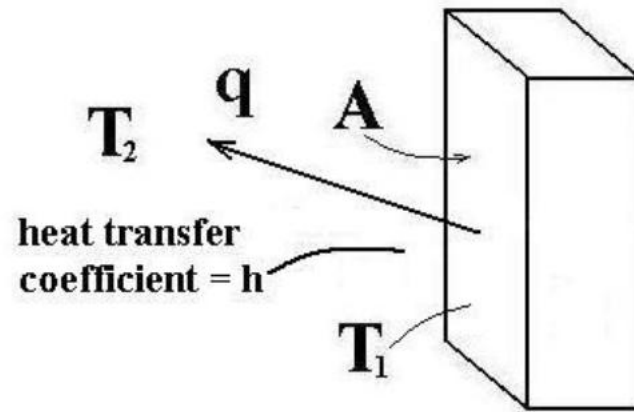

$$q = \frac{dQ}{dt} = h A (T_1 - T_2)$$

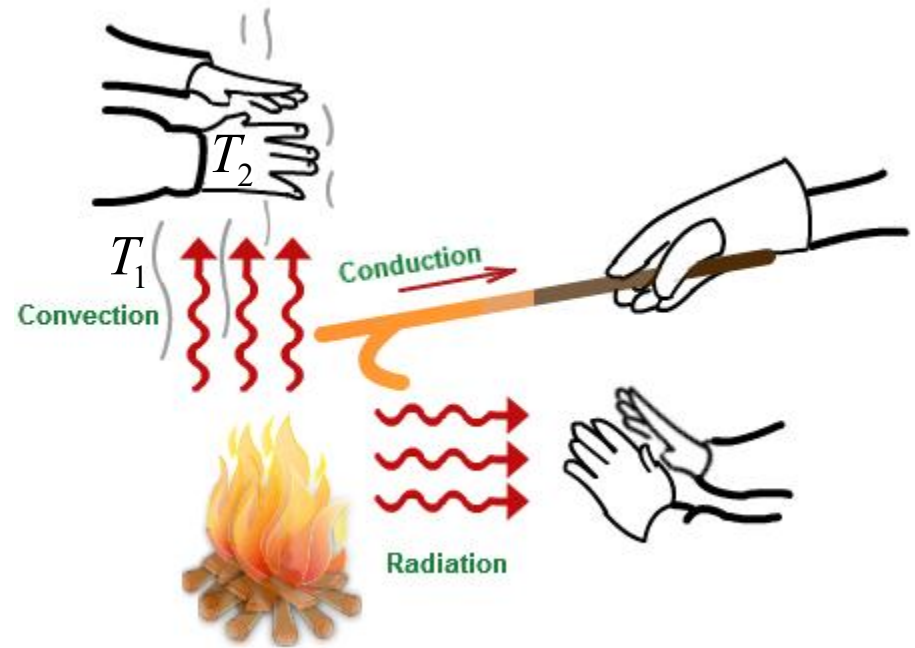

# Useful Equation of Temperature (5)

- Equation of Radiation, which describes heat transfer by electromagnetic waves (e.g. infrared waves).

$$P = e\sigma A(T^4 - T_c^4)$$

$P$  = radiated power

$A$  = radiating area

$\sigma$  = Stefan's constant

$\sigma = 5.6703 \times 10^{-8} \text{ watt/m}^2 \text{ K}^4$

$e$  = emissivity (=1 for ideal blackbody)

$T$  = temperature of radiator

$T_c$  = temperature of surroundings

$$\frac{P}{A} \approx e\sigma T^4$$

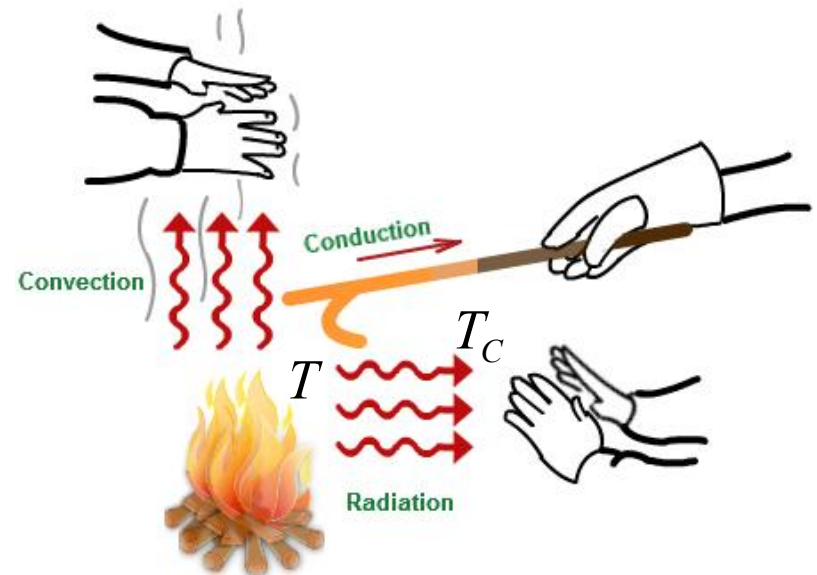

# Useful Equation of Temperature (6)

- Equation of Linear Expansion, which is proportional to temperature variation.

$$\Delta L = \alpha L_0 \Delta T$$

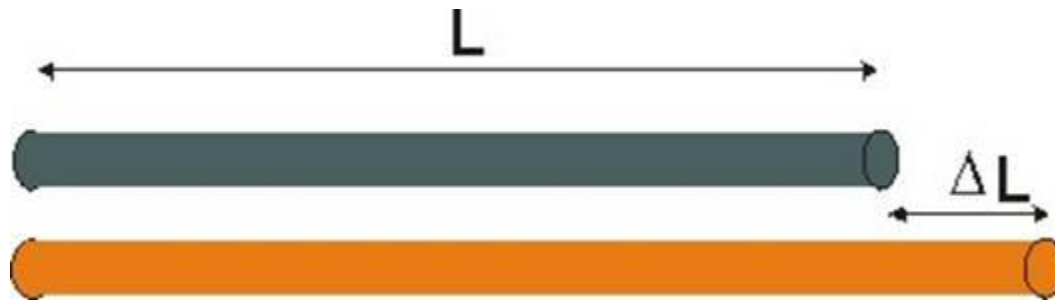

# Useful Equation of Temperature (7)

- Equation of Volume Expansion, which is proportional to temperature variation.

$$\Delta V = \beta V_0 \Delta T$$

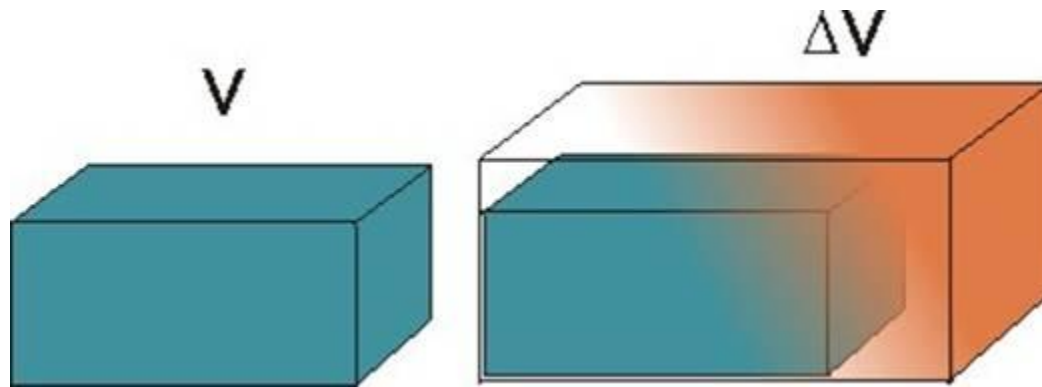

# Example

- ▶ A glass tube contains mercury. Its volume is  $200 \text{ cm}^3$  at  $20$  degrees Celsius. The volume expansion of glass is negligible. And, the coefficient of volume expansion of mercury is  $18 \div (10^5 \text{K})$ . If we observe that the volume of the mercury has increased by  $3.0 \text{ cm}^3$ , what is the value of the temperature?

- ▶ Answer:

$$\Delta V = \beta V_0 (T - T_0)$$

$$T = T_0 + \frac{\Delta V}{\beta V_0} = 20.0 + \frac{3.0}{18 \times 10^{-5} \times 200} = 103.33^\circ \text{C}$$

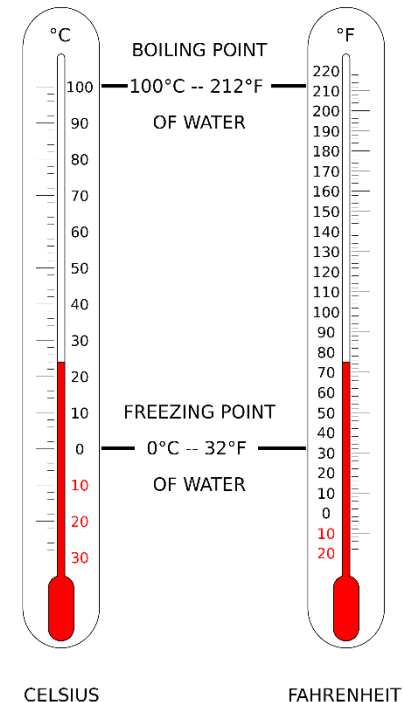

# Outline

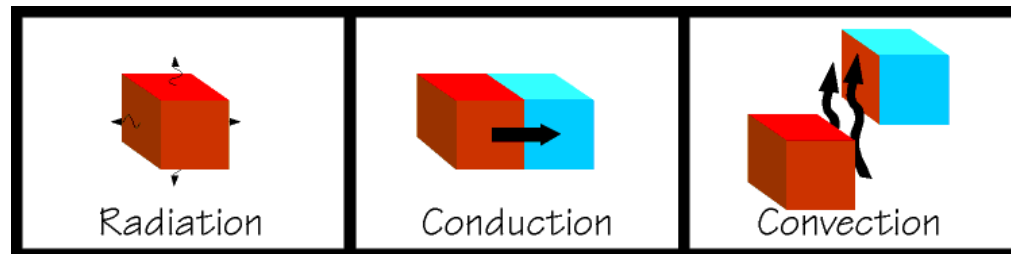

► Understanding of Temperature

► Computation of Temperature

► Measurement of Temperature

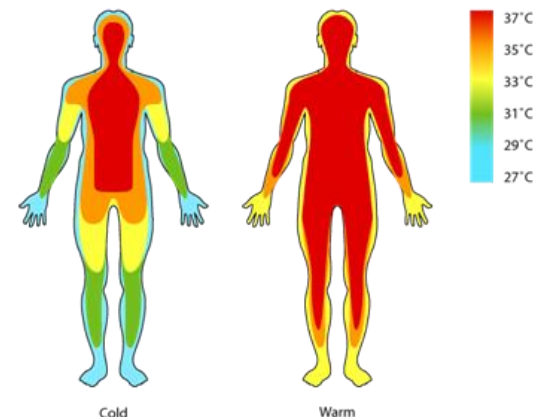
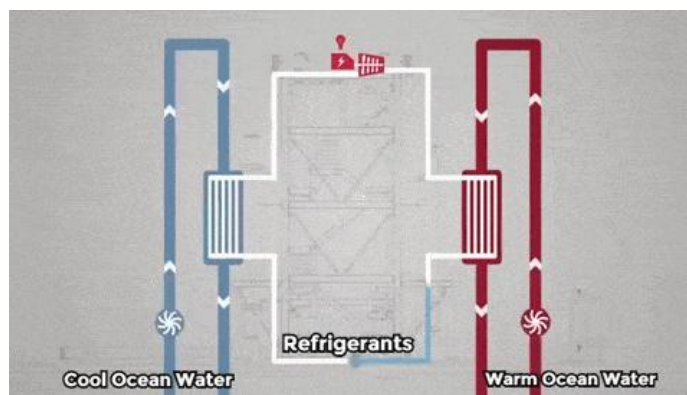
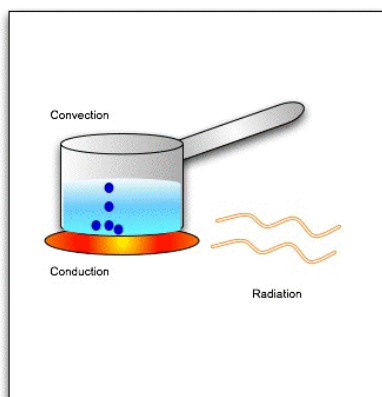
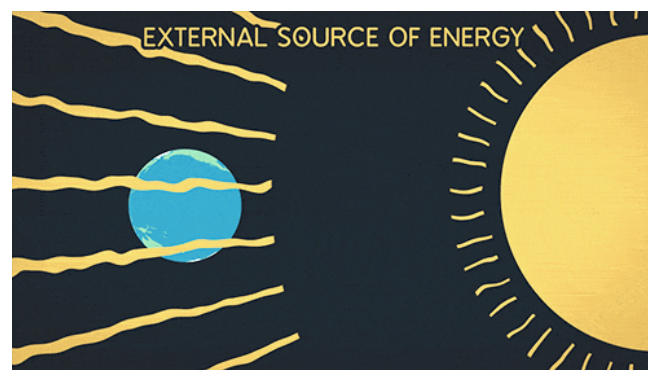

# Temperature Control in Industry

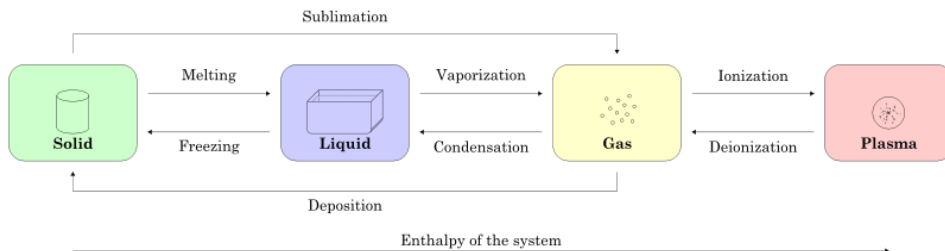
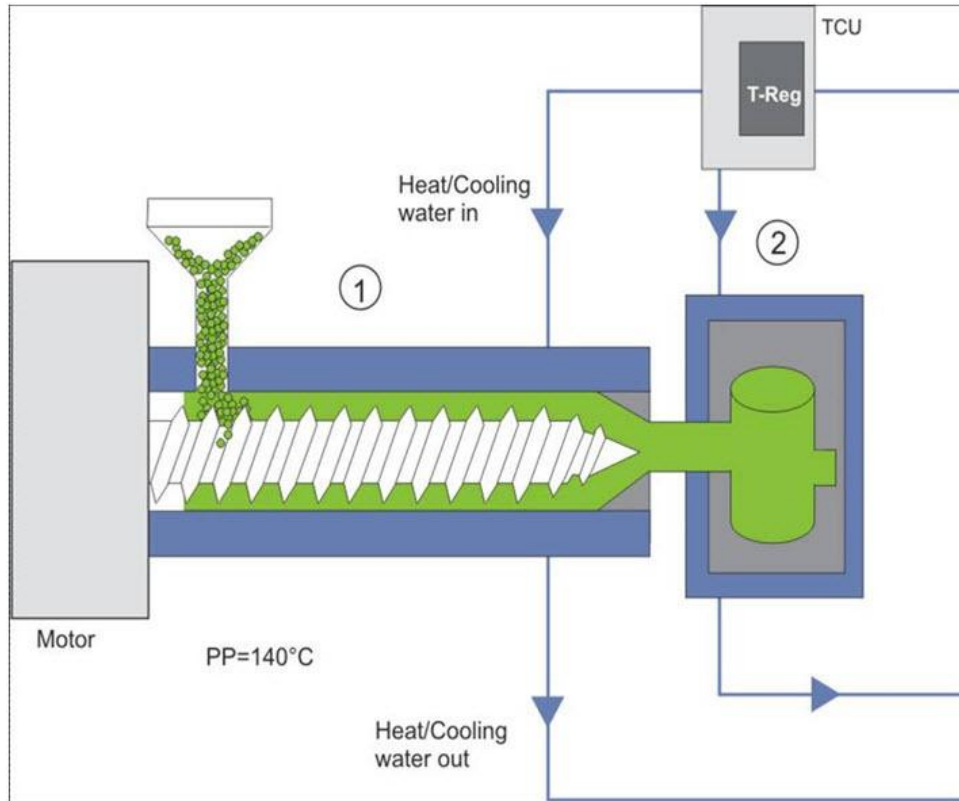

# Temperature Control in Buildings

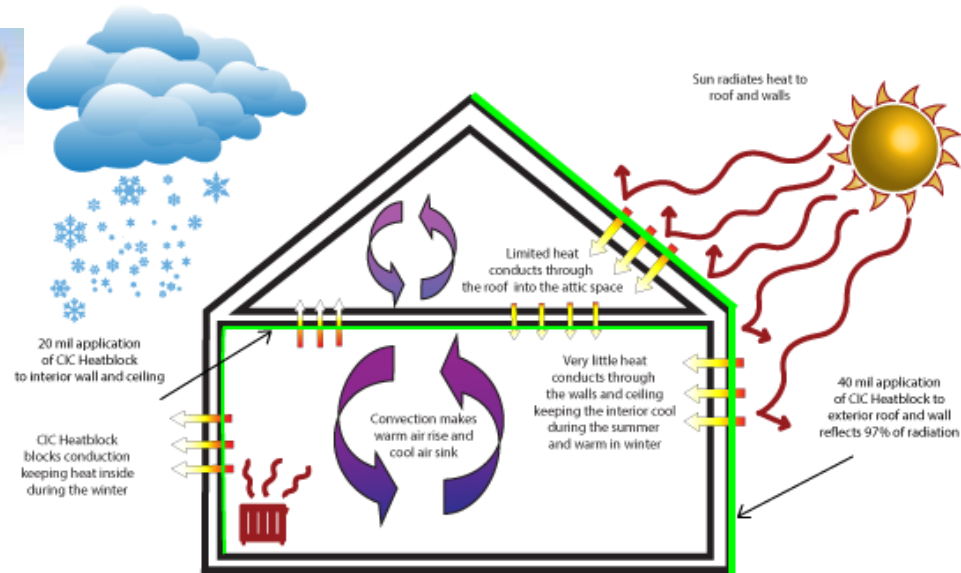
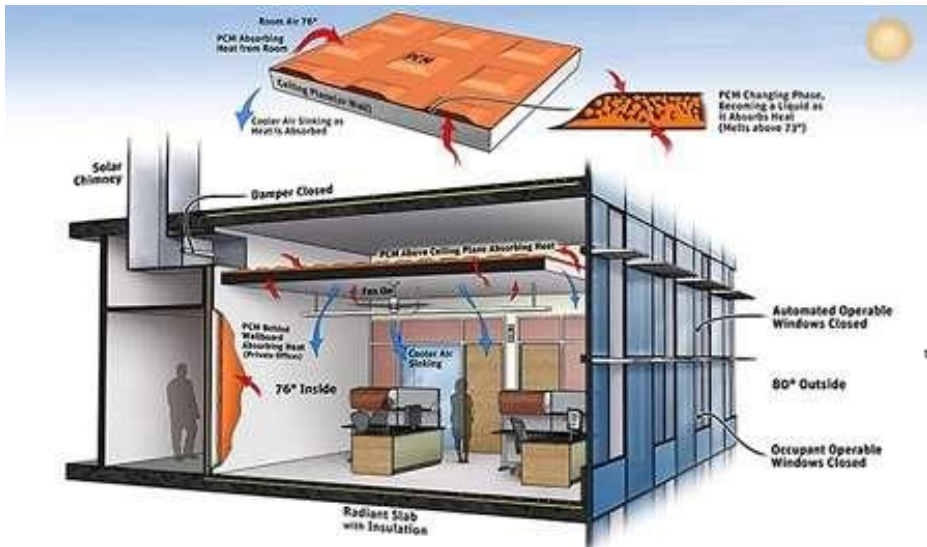

# Temperature Control in Agriculture



# Principles of Measurement

- ▶ **Principle 1:** Temperature is converted to DC voltage which could be measured automatically.
- ▶ **Principle 2:** Temperature is converted to resistance, which is then converted to DC voltage. DC voltage could be measured automatically.

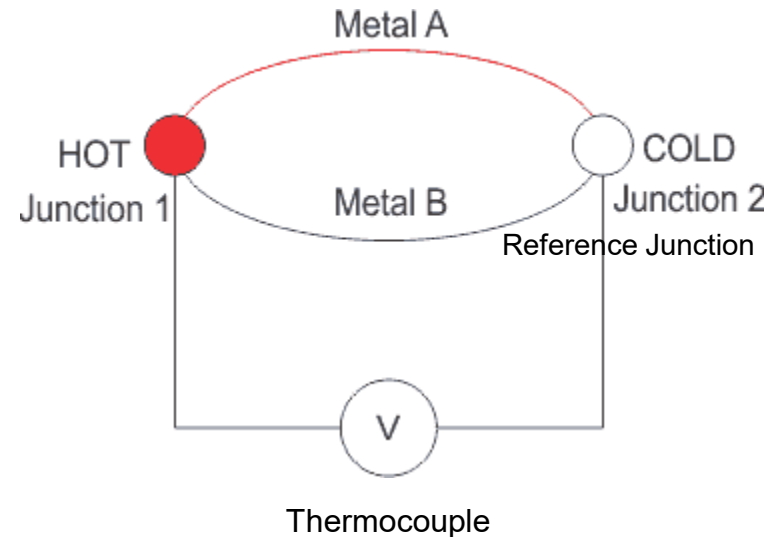
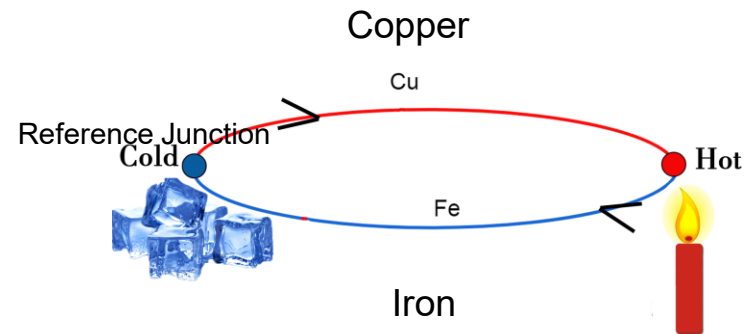

Thermistor

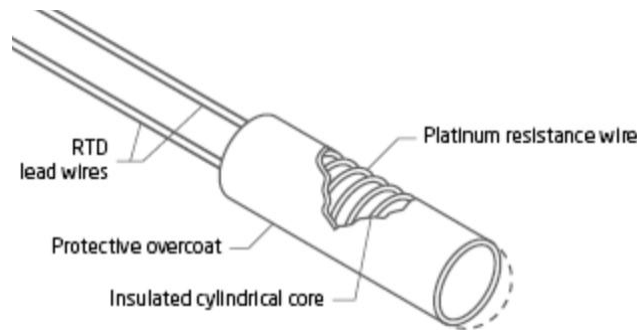

Resistance Temperature Detector (RTD)

# How to apply principle 1 to design digital measurement and sensing systems for temperature?

- ▶ Temperature is converted to DC voltage which is measured by digital voltmeter (e.g. microcontrollers).

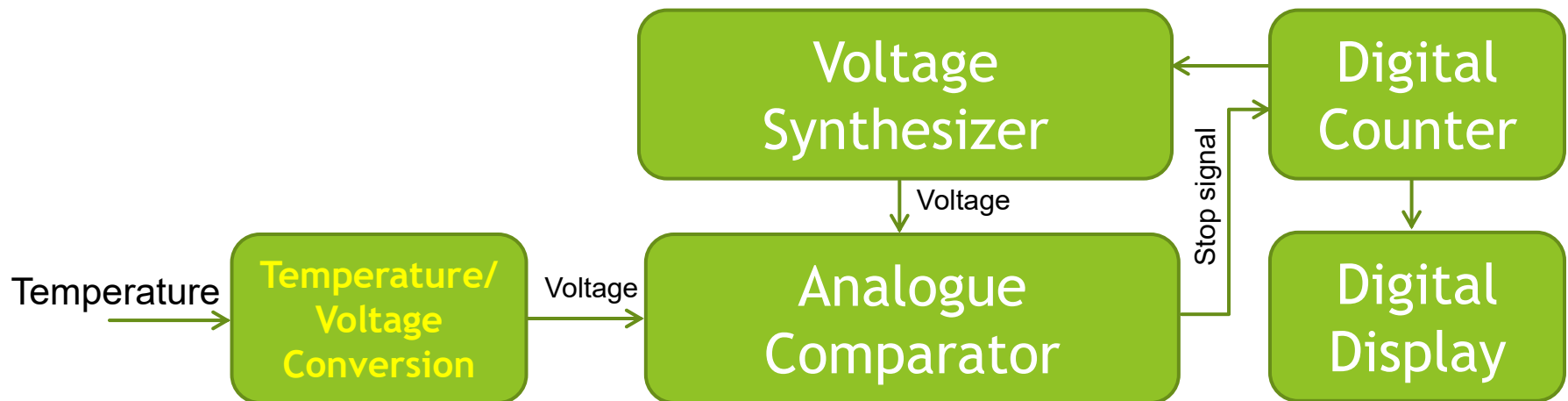

All microcontrollers are programmable digital sensors of voltage!

# How to convert temperature into DC voltage?

- ▶ Two conductors of different types are connected at the two ends.
- ▶ When the temperatures at the two ends are different, there is a flow of electrons inside the loop.
- ▶ Hence, the temperature could be measured through the measurement of DC voltage.

$$V = k\Delta T = k(T_{hot} - T_{cold})$$

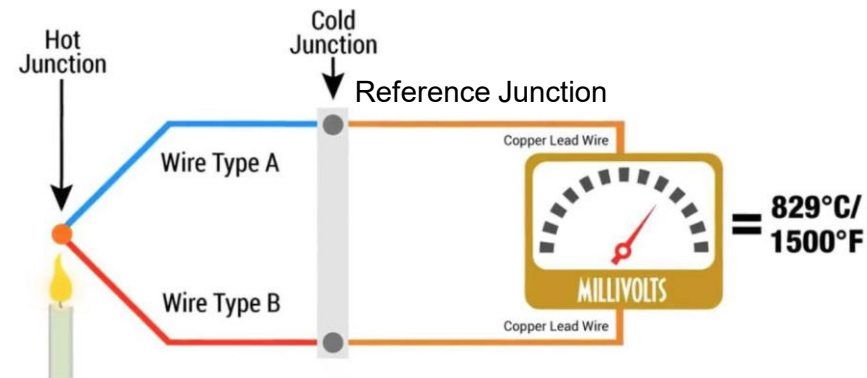
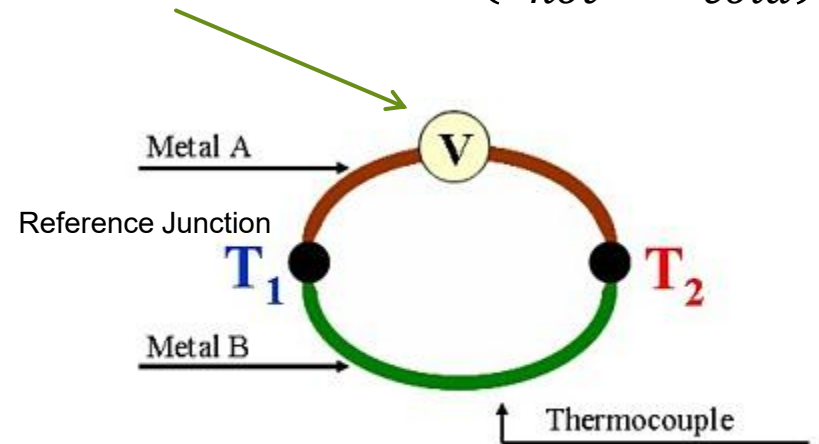

# Example of Thermocouple's Body Design (measurement range: $< 2000\text{ }^{\circ}\text{C}$ )

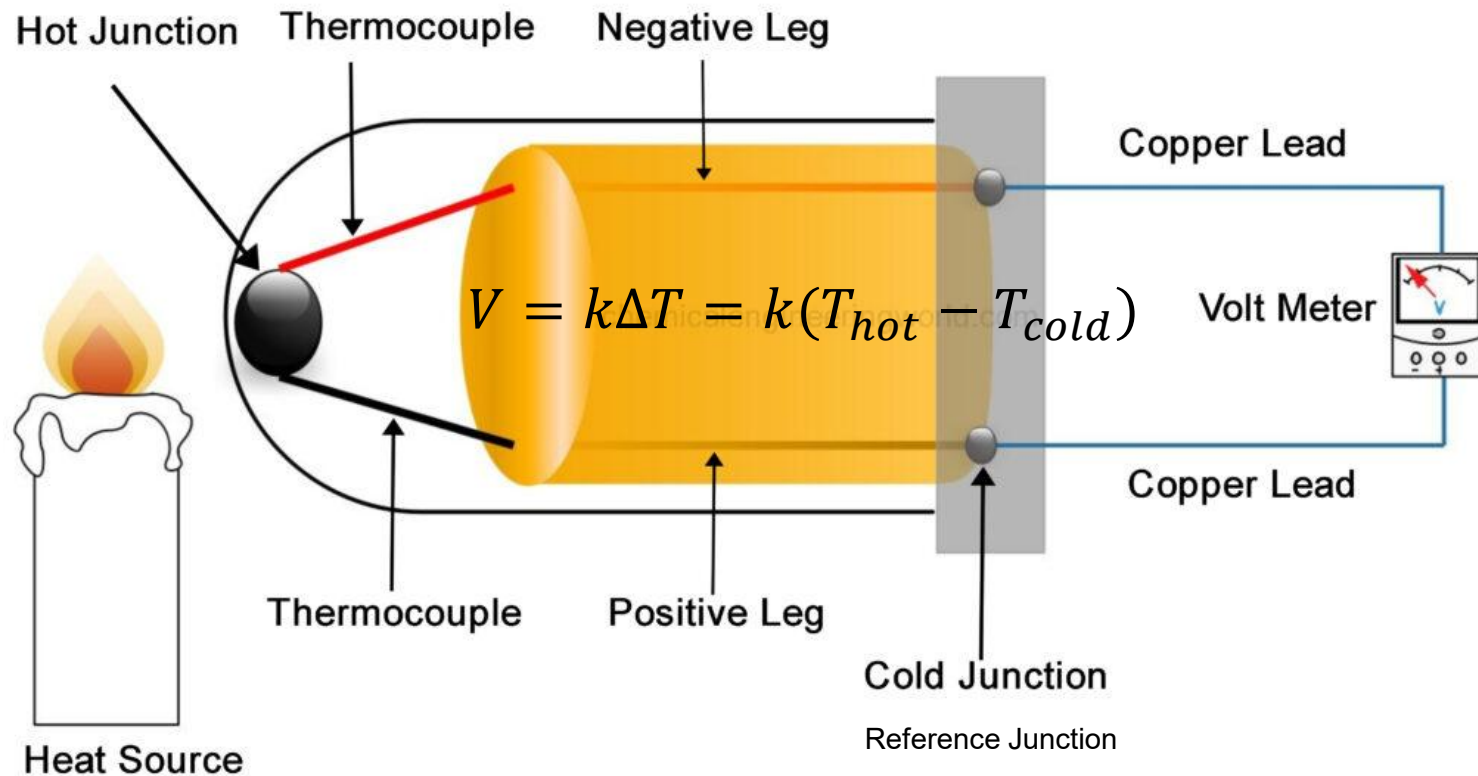

# Example of Thermocouple's Circuit Design

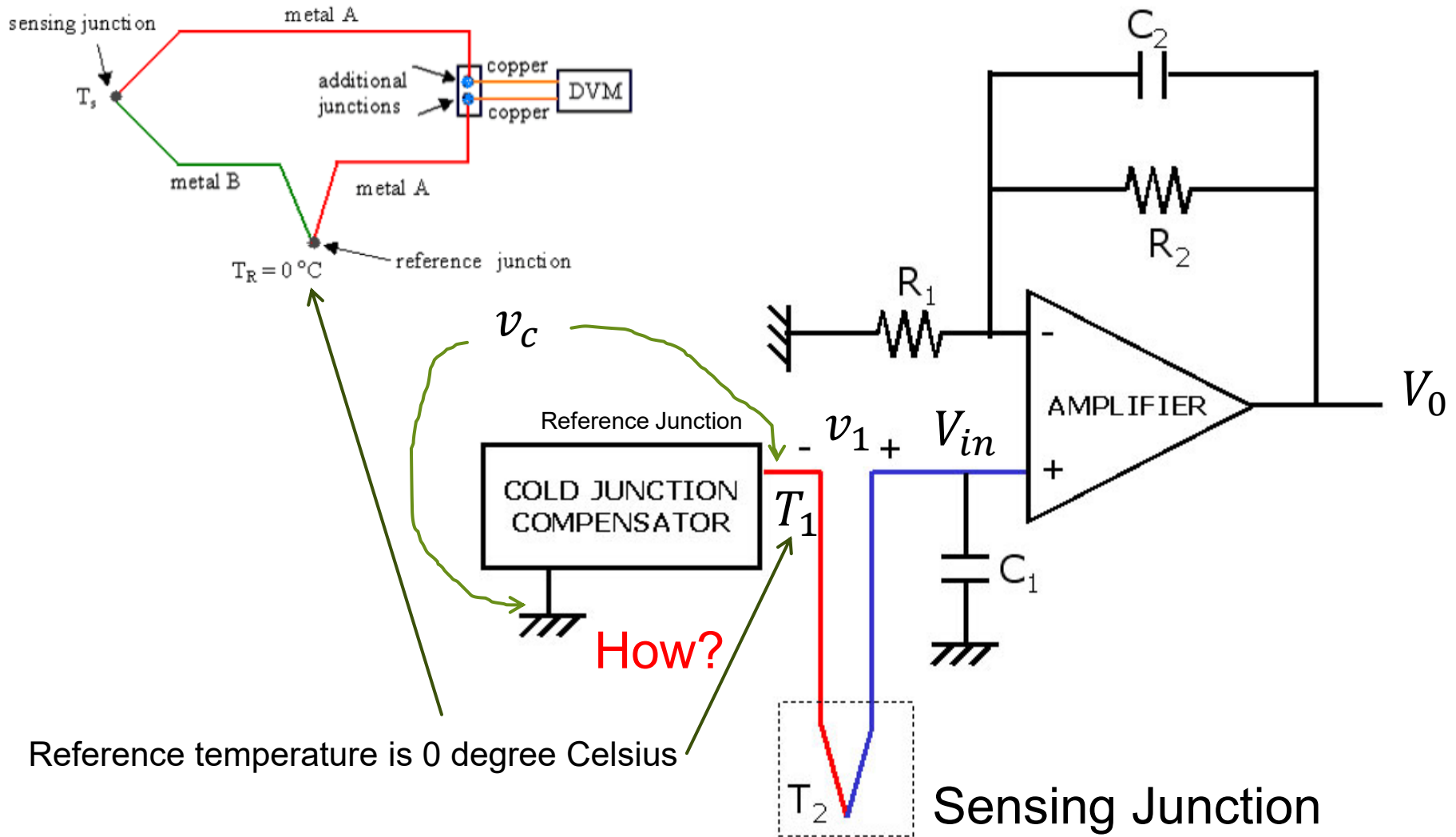

# Cold Junction Compensation

When  $T_2 = 0$ , output voltage is:  $v_1 = v_0$

Then, compensation voltage will be:  $v_c = -v_0$

$$V_{in} = v_c + v_1$$

$$V_0 = V_{in} - \frac{V_{in}}{R_1} R_2$$

$$V_0 = \frac{R_1 - R_2}{R_1} V_{in}$$

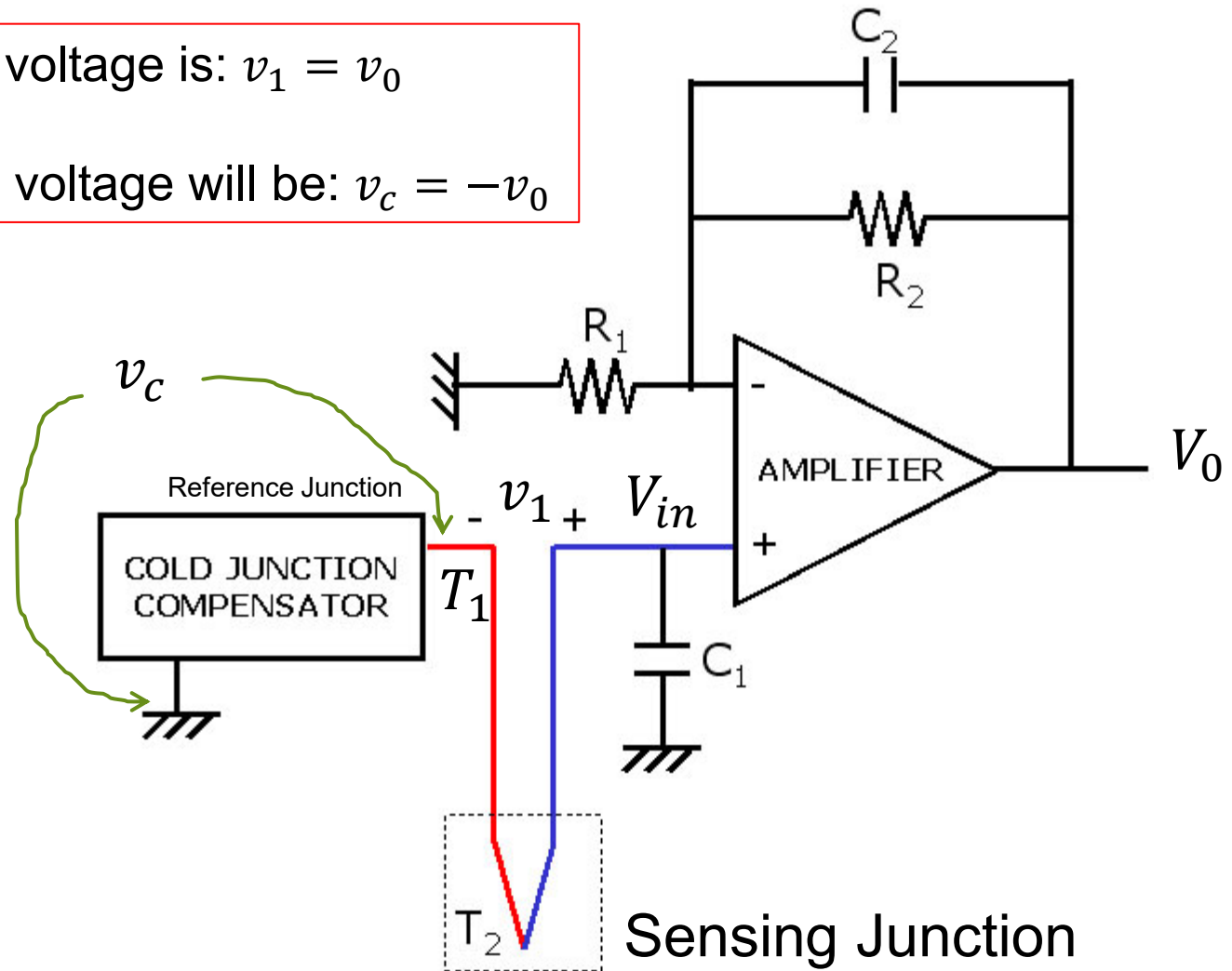

# How to apply principle 2 to design digital measurement and sensing systems for temperature?

- ▶ Temperature is converted to resistance, which is then converted into DC voltage. DC voltage is measured by digital voltmeter (e.g. microcontrollers).

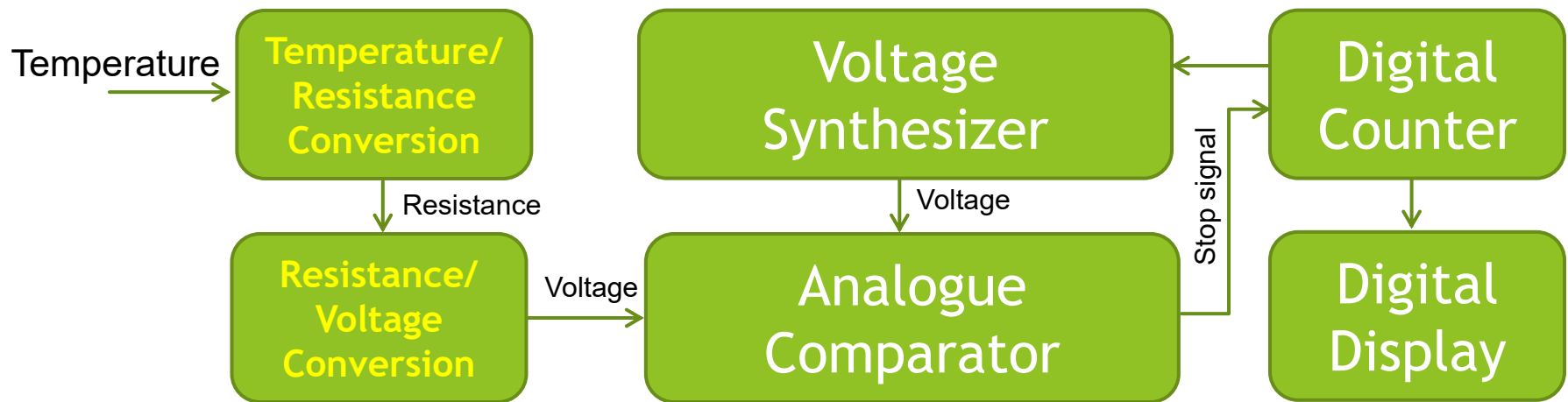

All microcontrollers are programmable digital sensors of voltage!

# How to convert temperature into resistance?



# Use of Thermistor ( $< 100\text{ }^{\circ}\text{C}$ )

- ▶ Temperature sensitive materials are wound on a rod so as to produce temperature sensitive resistors, which are called thermistors.
- ▶ The resistance values of the thermistors can be measured by a bridge circuit.

- Less expensive
- Fast response

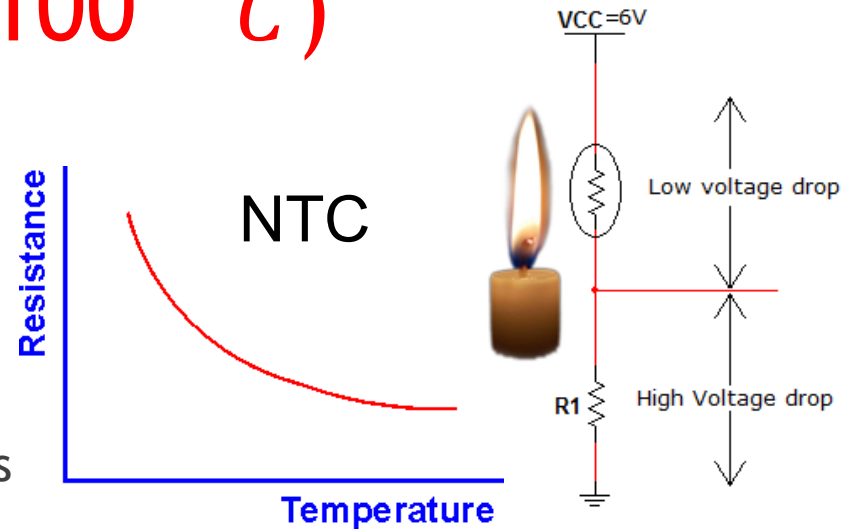

Negative Temperature Coefficient

Positive Temperature Coefficient

# Example of Thermistors

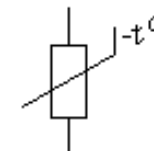
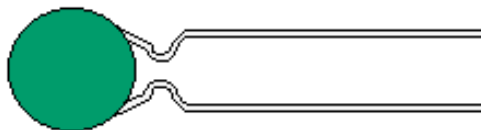
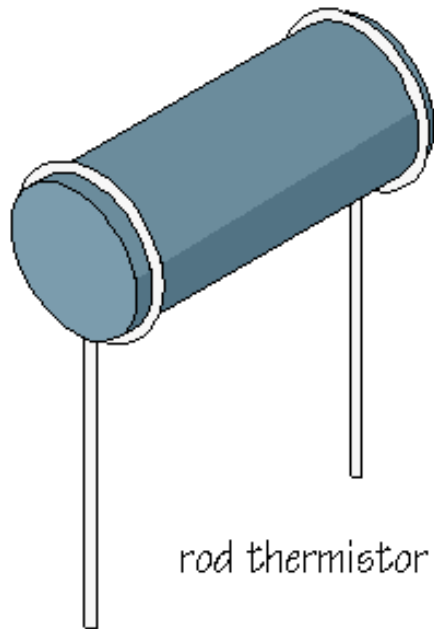
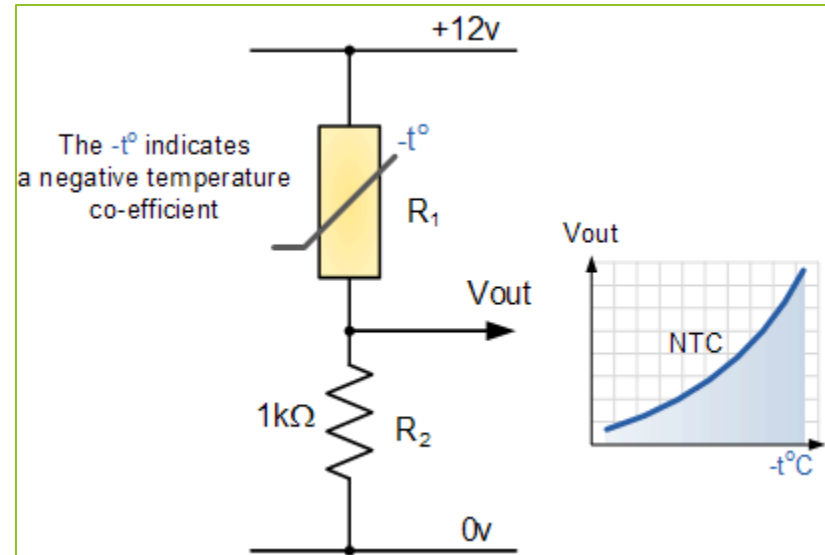
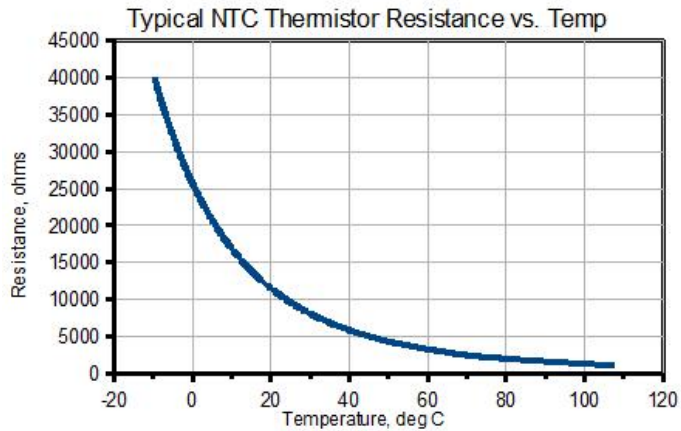

## Use of RTD ( $< 400\text{ }^{\circ}\text{C}$ )

- ▶ Other than thermistors, there are other temperature sensitive materials such as thin-film elements, wire-wound elements, coiled elements.
- ▶ These materials (e.g. platinum, nickel, or copper) are called resistance temperature detectors, or RTD in short.
- ▶ Temperature could be converted to resistance values with the use of RTD.

- Better accuracies
- Wider measurement ranges

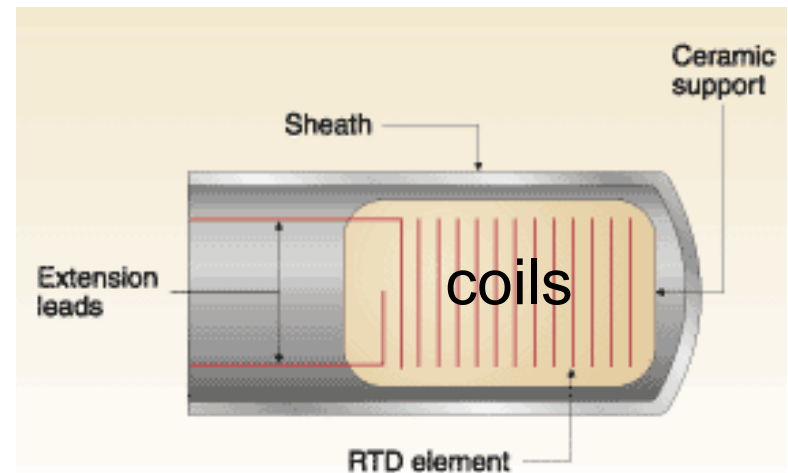
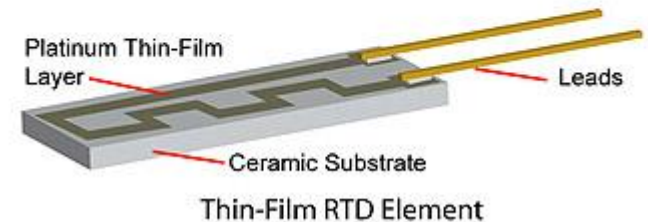
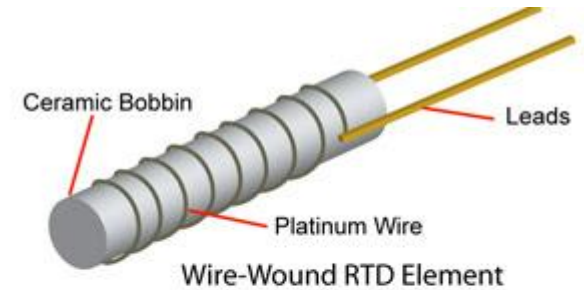

RTD=Resistance Temperature Detector

# How to convert resistance to DC voltage?

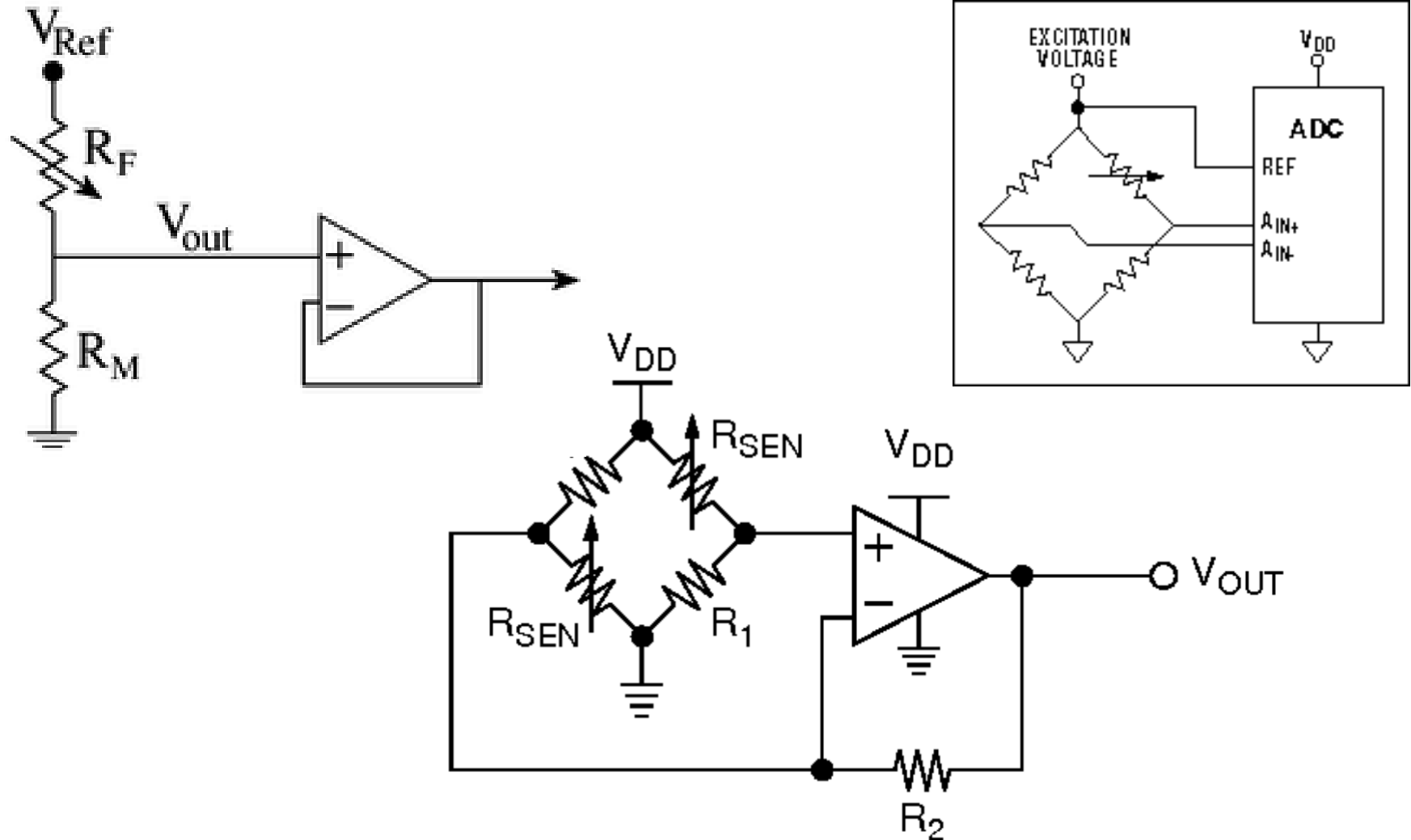

# Other Principles ...

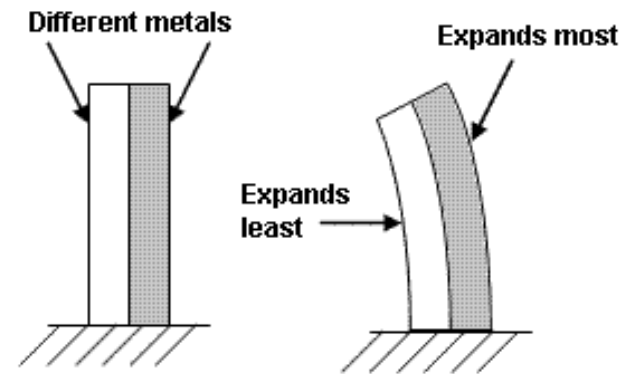
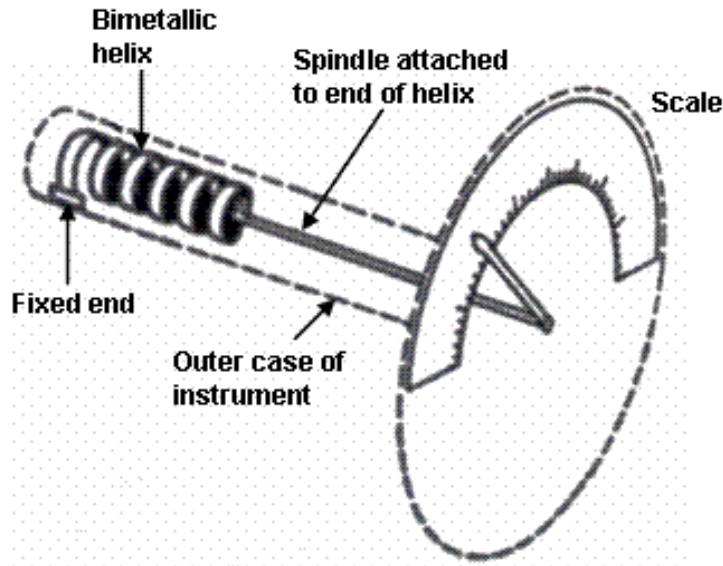
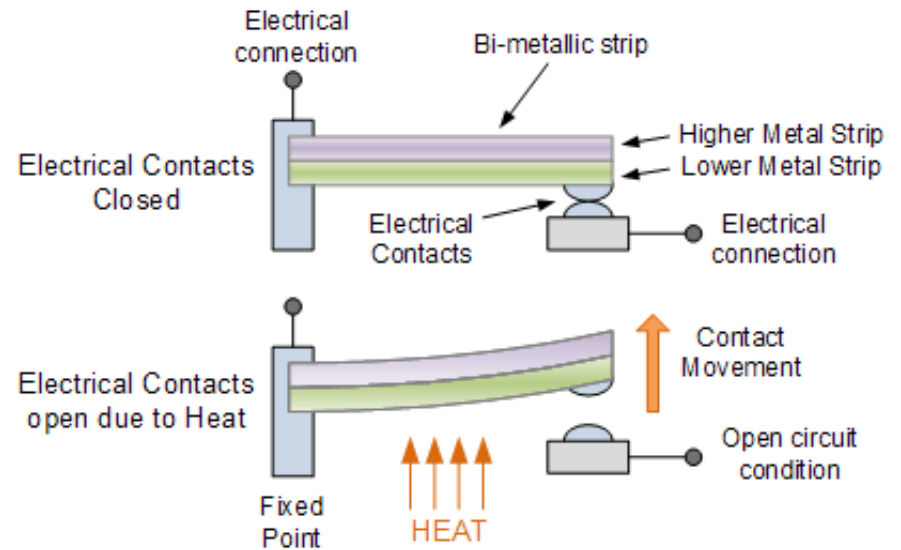
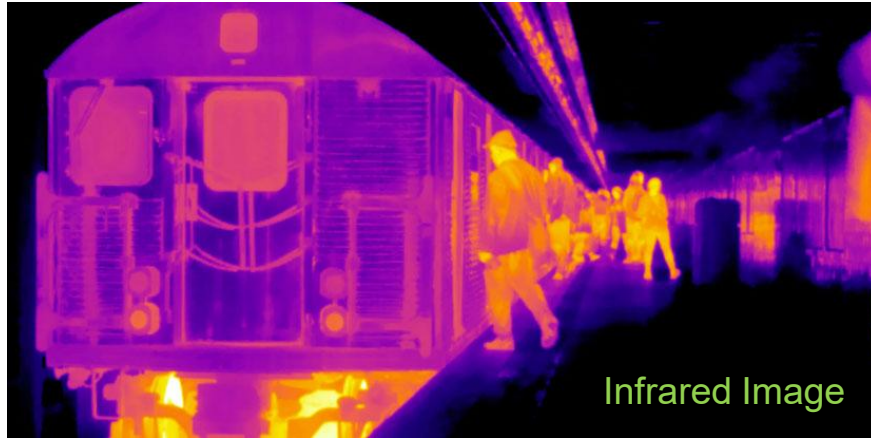

# Remember to Do Calibration

- ▶ Curve fitting for calibration:
  - ▶  $Y_i$  is produced by  $X_i$
  - ▶  $Z_i$  is computed from  $Y_i$
  - ▶  $Z_i$  must be equal to  $X_i$

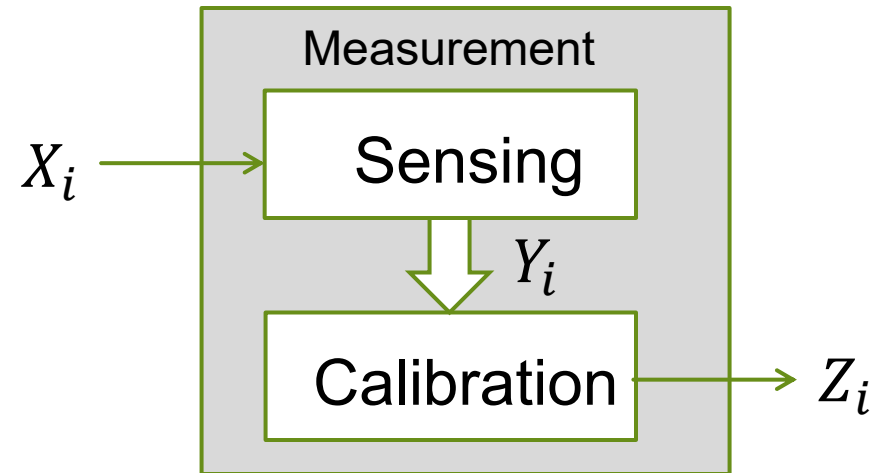

Calibrated Values  $Z_i$

Measured Values  $Y_i$

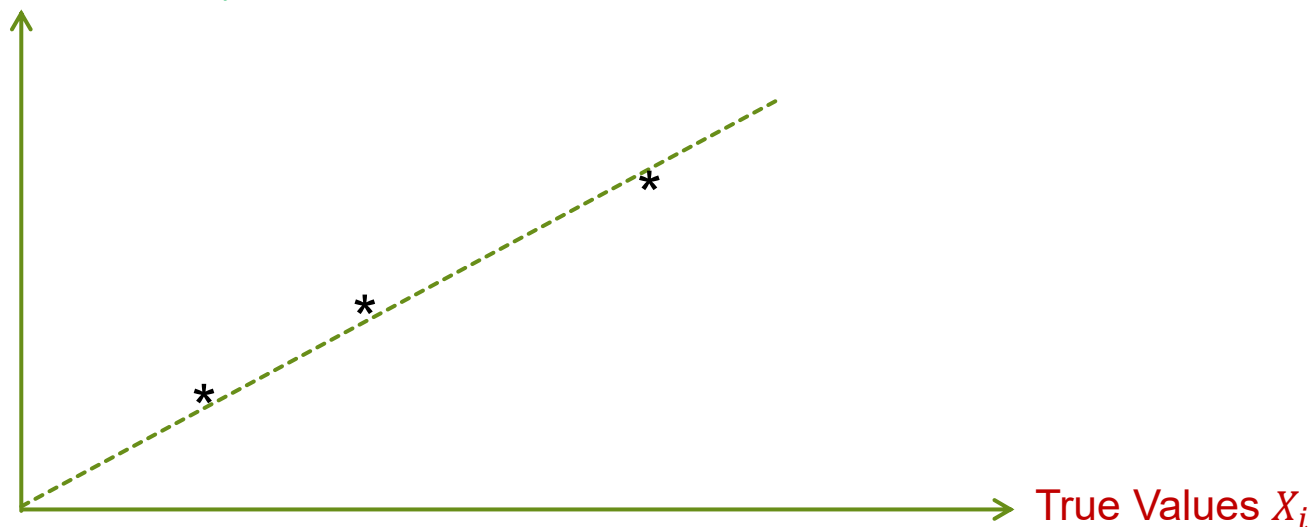

# Remember to Do Error Analysis

- ▶ Systematic error = mean value - true value
- ▶ Repeatability error = value with maximum error - mean value
- ▶ Accuracy = value with minimum error - mean value
- ▶ Hysteresis error = |measured value in increasing - measured value in decreasing|

For each true value, we can do error analysis

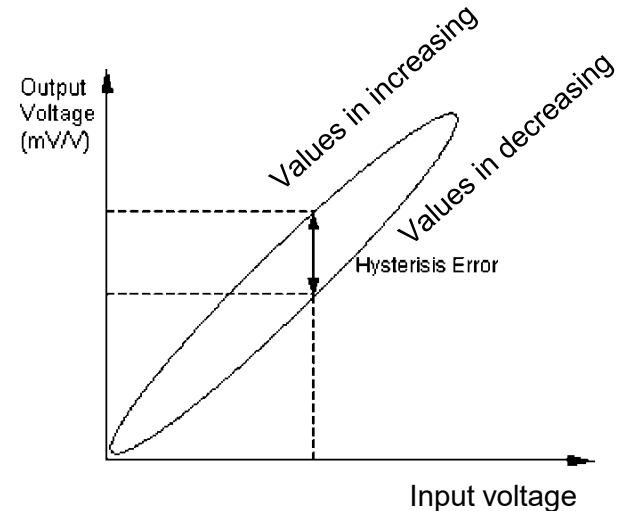
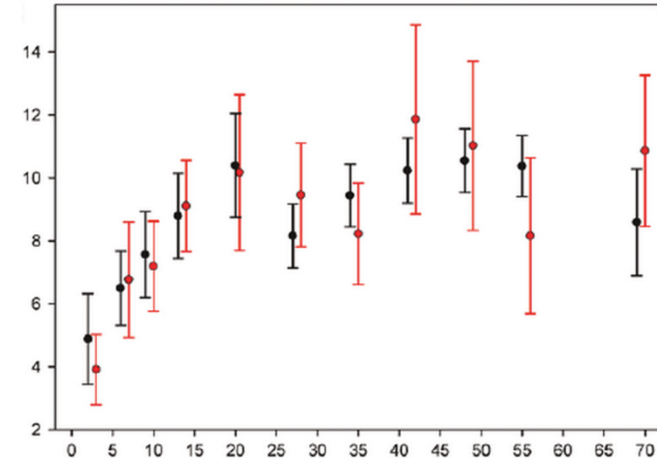

# Summary

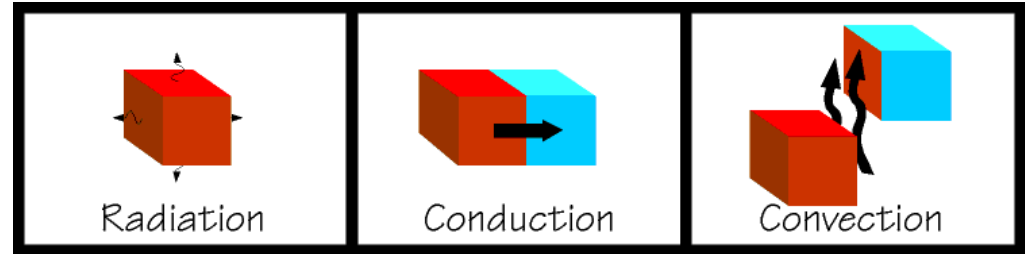

► Understanding of Temperature

► Computation of Temperature

► Measurement of Temperature

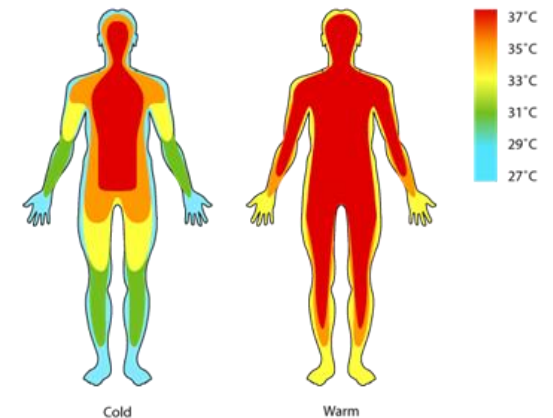
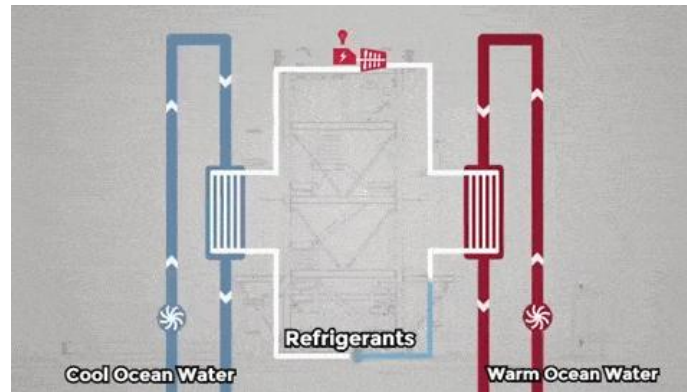
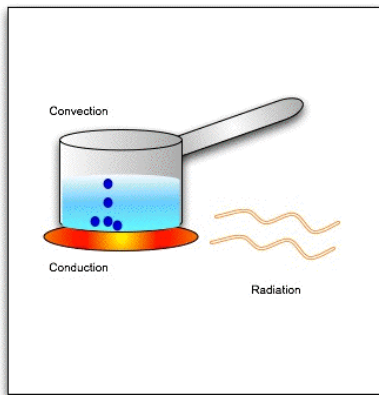
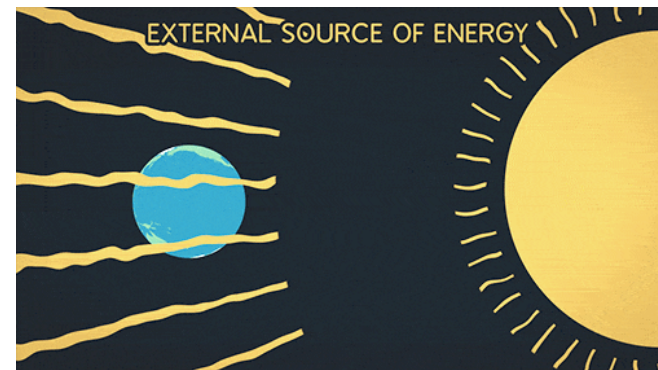

# Outline of Module 4

- ▶ Lecture 1:
  - ▶ Measurement of Pressure
- ▶ Lecture 2:
  - ▶ Measurement of Temperature
- ▶ Lecture 3:
  - ▶ Measurement of Humidity
- ▶ Lecture 4:
  - ▶ Measurement of Vibration
- ▶ Lecture 5:
  - ▶ Measurement of Air Quality

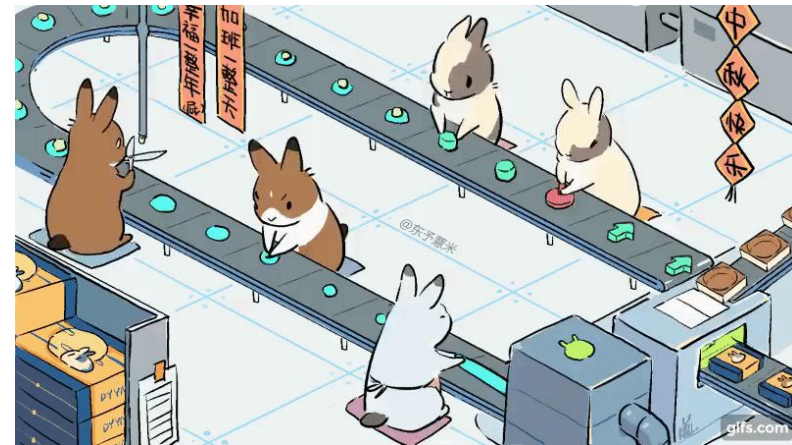



**NANYANG  
TECHNOLOGICAL  
UNIVERSITY**

**School of Mechanical & Aerospace Engineering**

Design, Machine, Control, Intelligence

Module 4 Lecture 3

MA4822

# Measurement of Humidity

Xie Ming, PhD (France)

[mmxie@ntu.edu.sg](mailto:mmxie@ntu.edu.sg)

<http://personal.ntu.edu.sg/mmxie>

# Outline

- ▶ Understanding of Humidity
- ▶ Computation of Humidity
- ▶ Measurement of Humidity

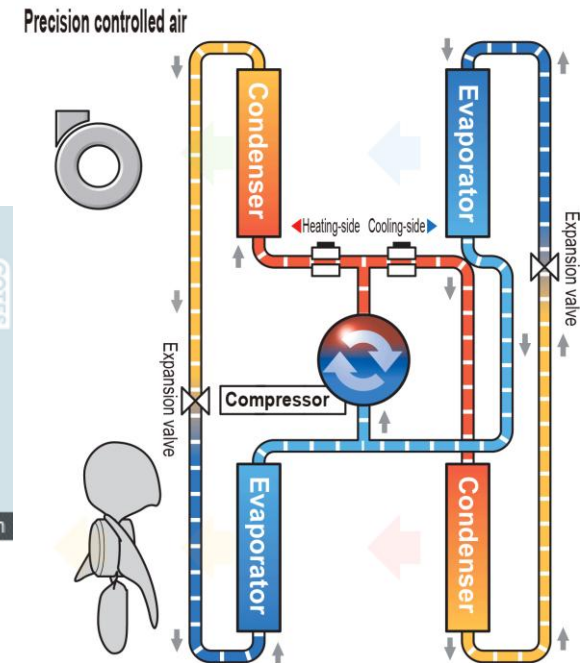
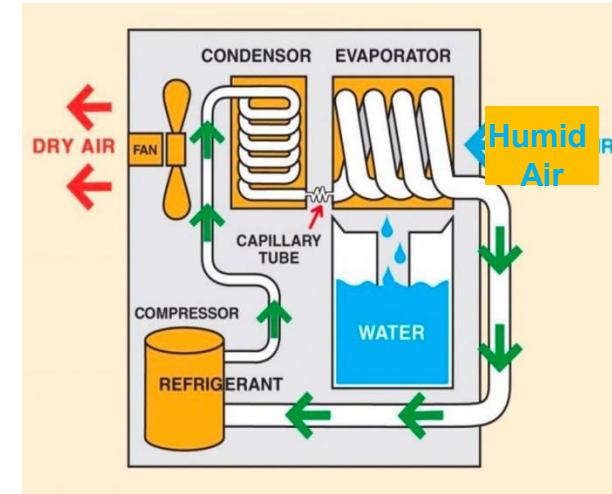
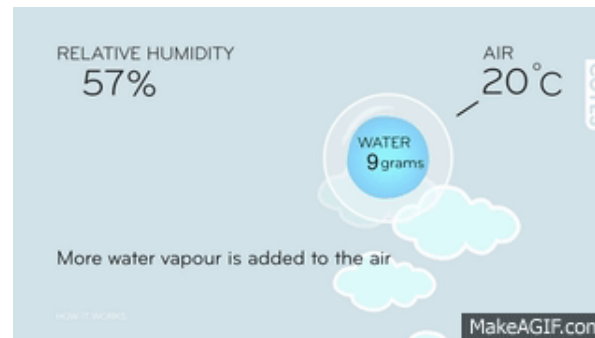
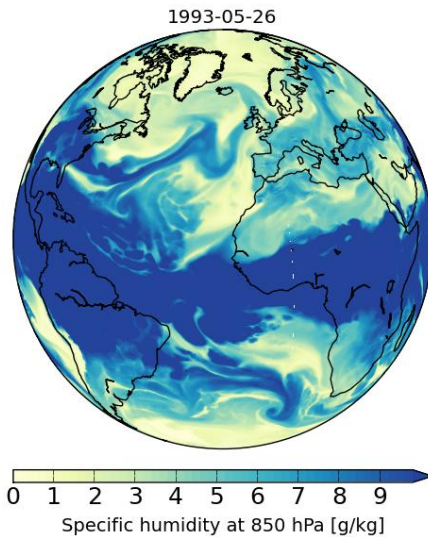

# Outline

- ▶ Understanding of Humidity
- ▶ Computation of Humidity
- ▶ Measurement of Humidity

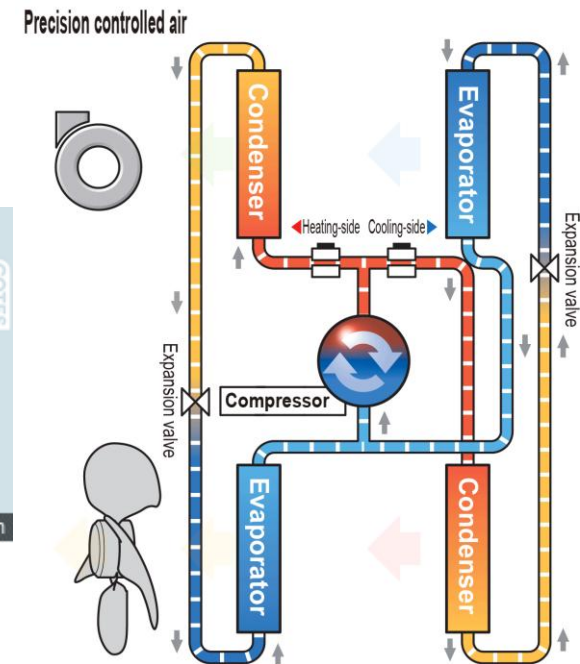
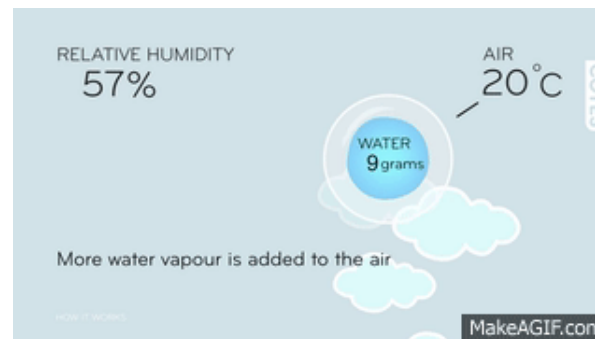
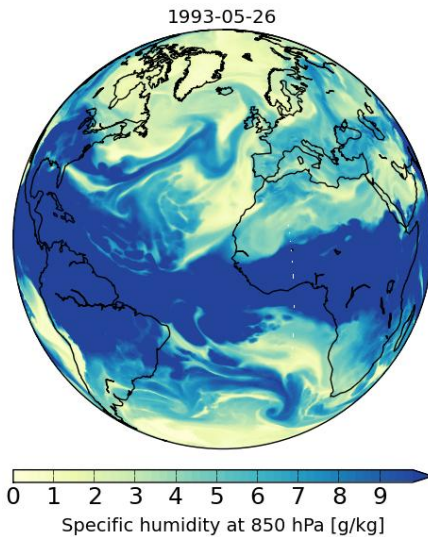
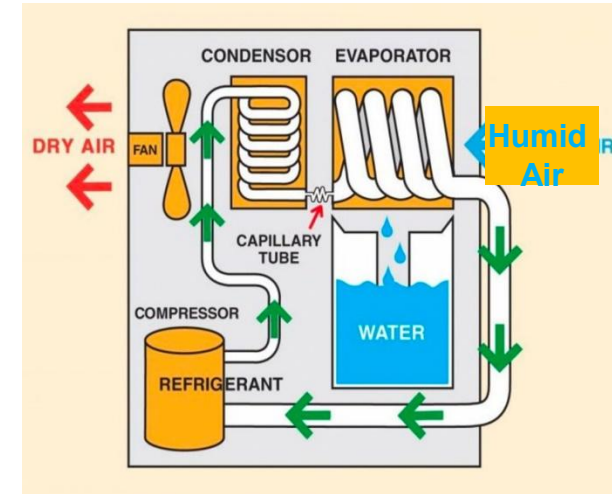

# Understanding Humidity (1)

- ▶ Humidity is related to water vapour in air.

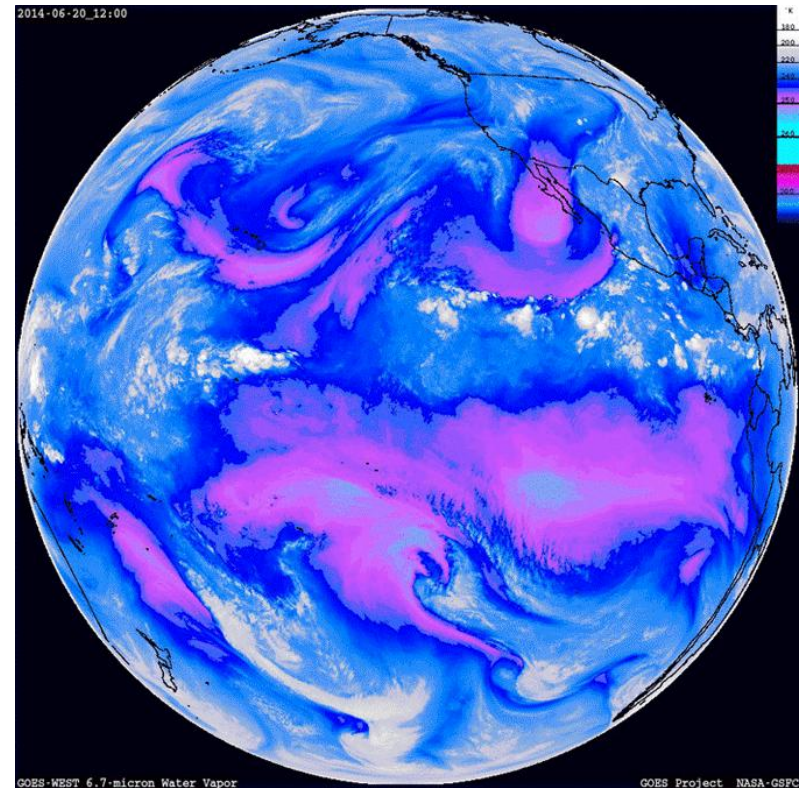

# Understanding Humidity (2)

- ▶ Water can exist in three states which can make transitions among them.

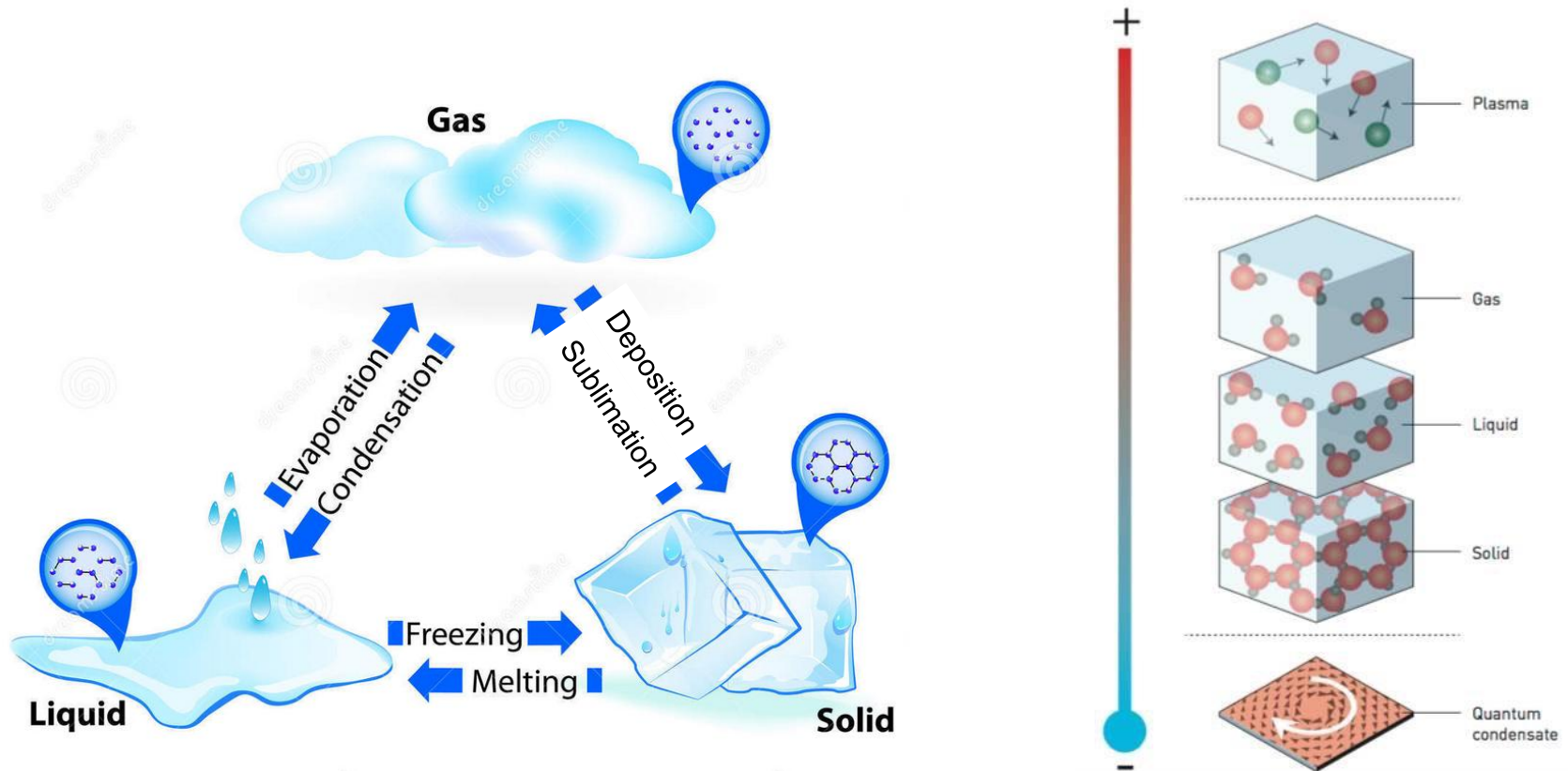

# What is condensation?

- ▶ It is a process which makes vapor to become liquid.



Surface's Temperature

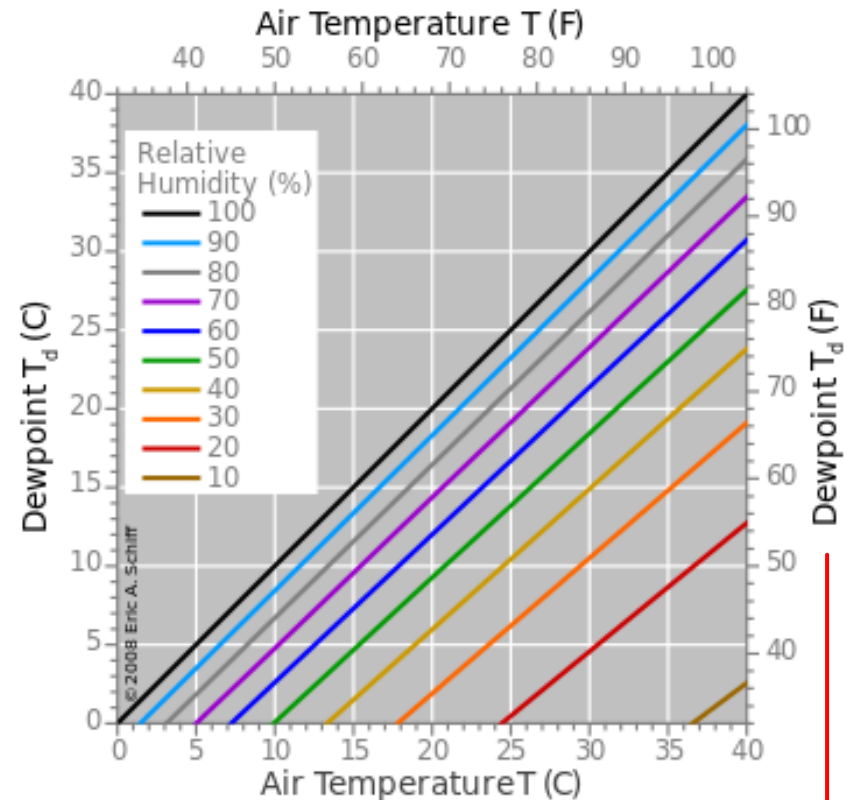

Dew Point Depends on Humidity

Dew Point: It is the surface's temperature below which Vapour becomes Liquid.

# Example of Condensation

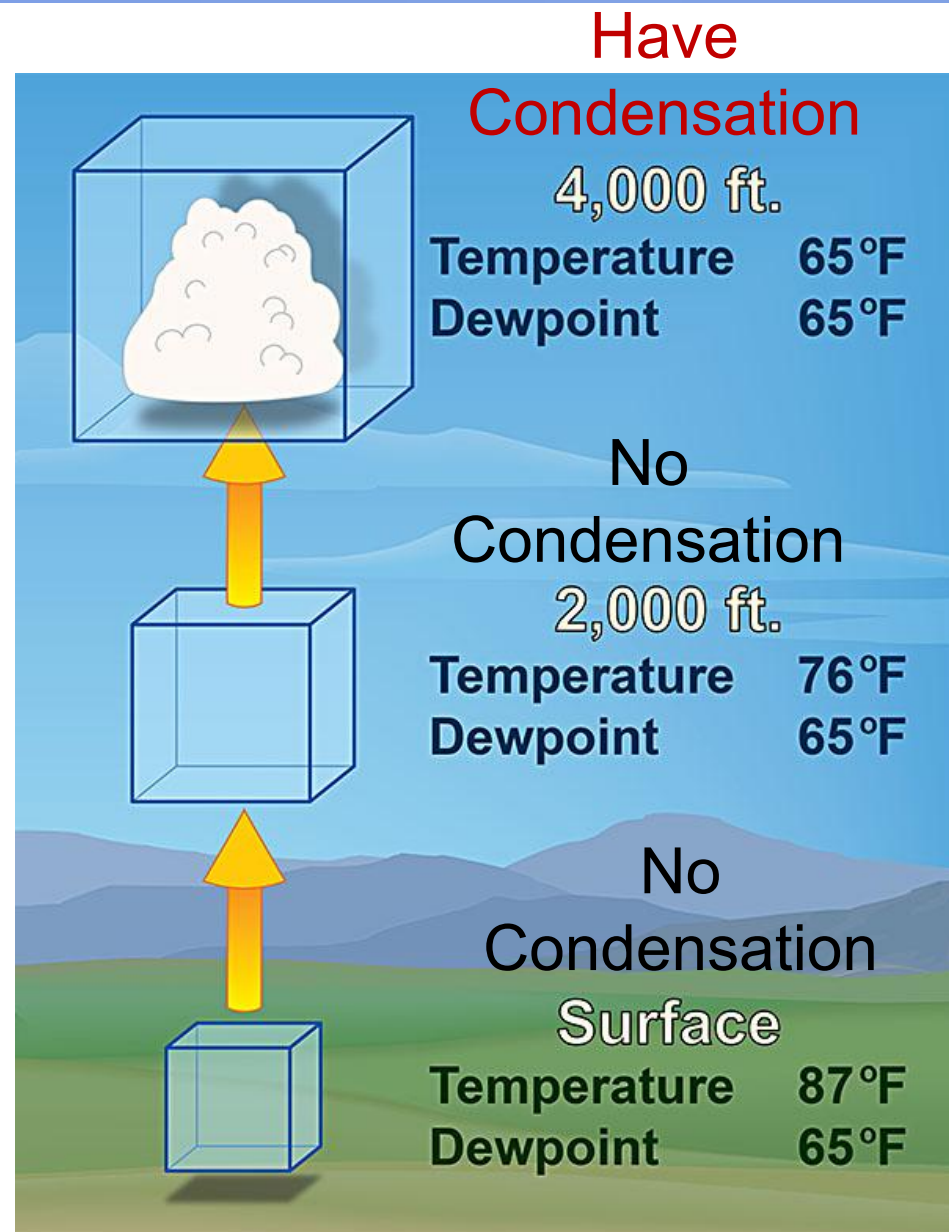
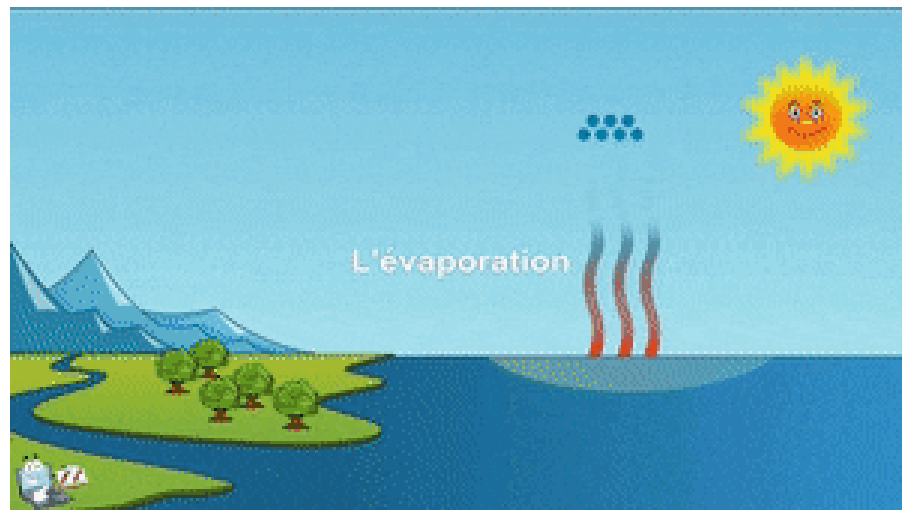

# Example of Using Condensation to Get Pure Water ...

Temperature must be below dew point.

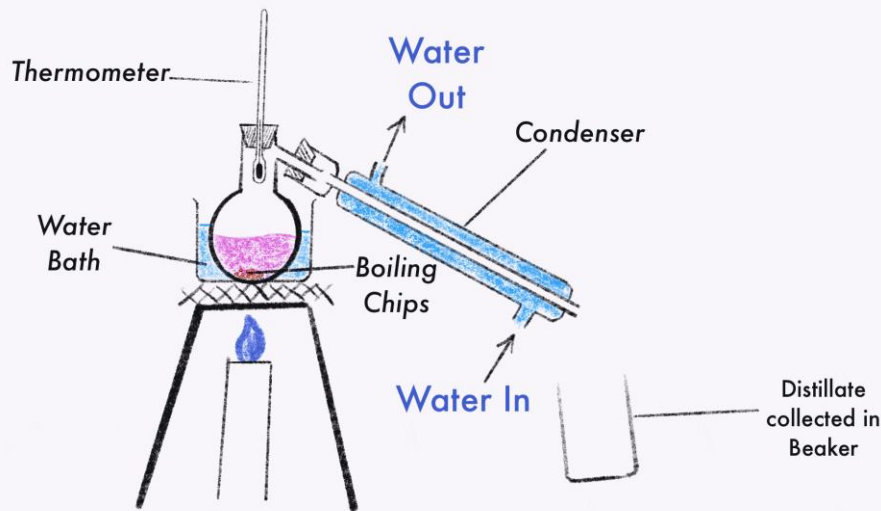

Distillation of a mixture of ethanol and water

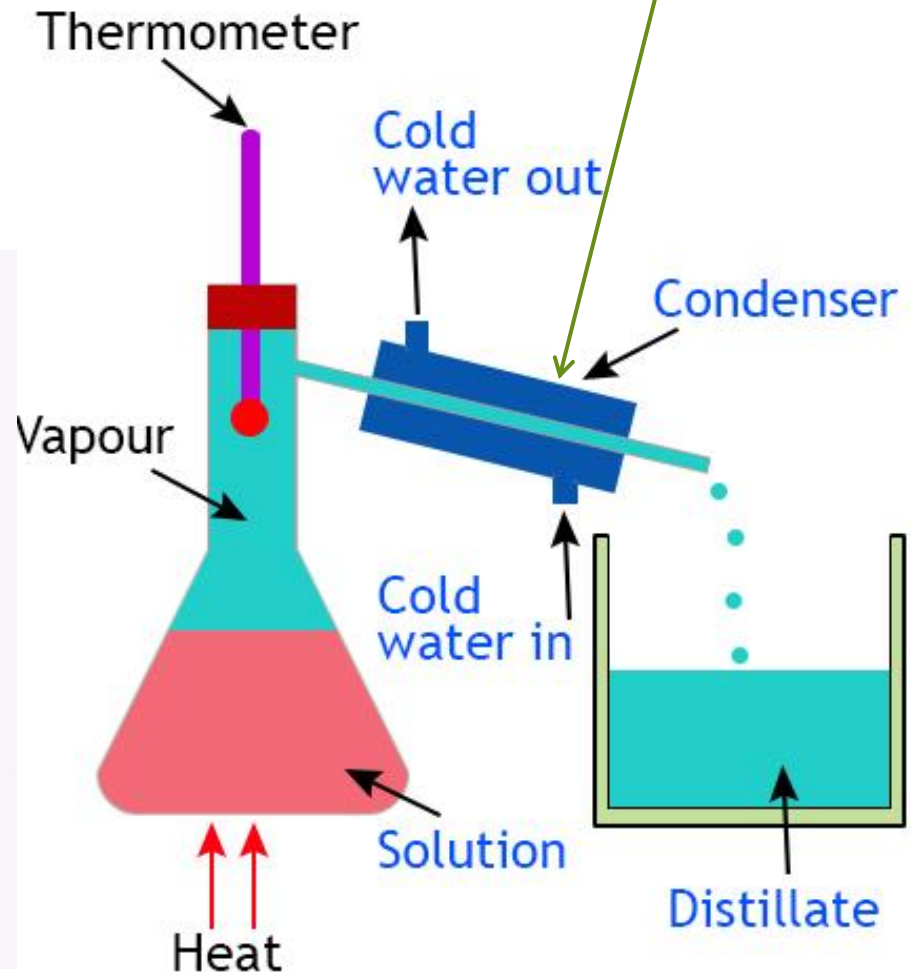

# Application of Condensation to Recycle the Use of Cooling Water ...

Steam becomes water through condensation process

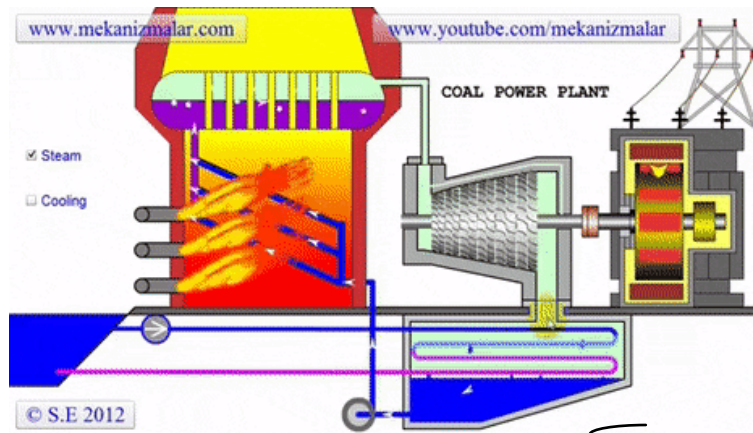

Output of Electricity

Secondary

Primary

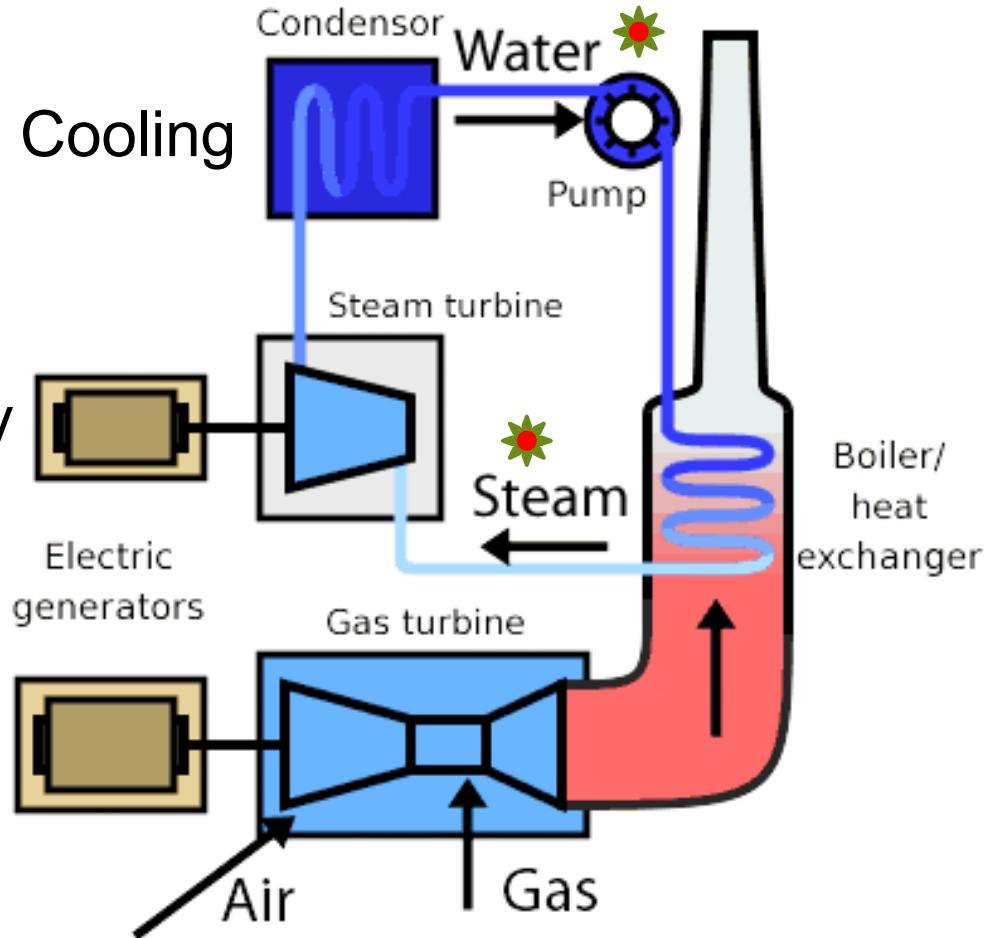

# What is deposition?

- **Deposition** is the transition of a substance directly from the gas state to the solid state without passing through the intermediate liquid state.

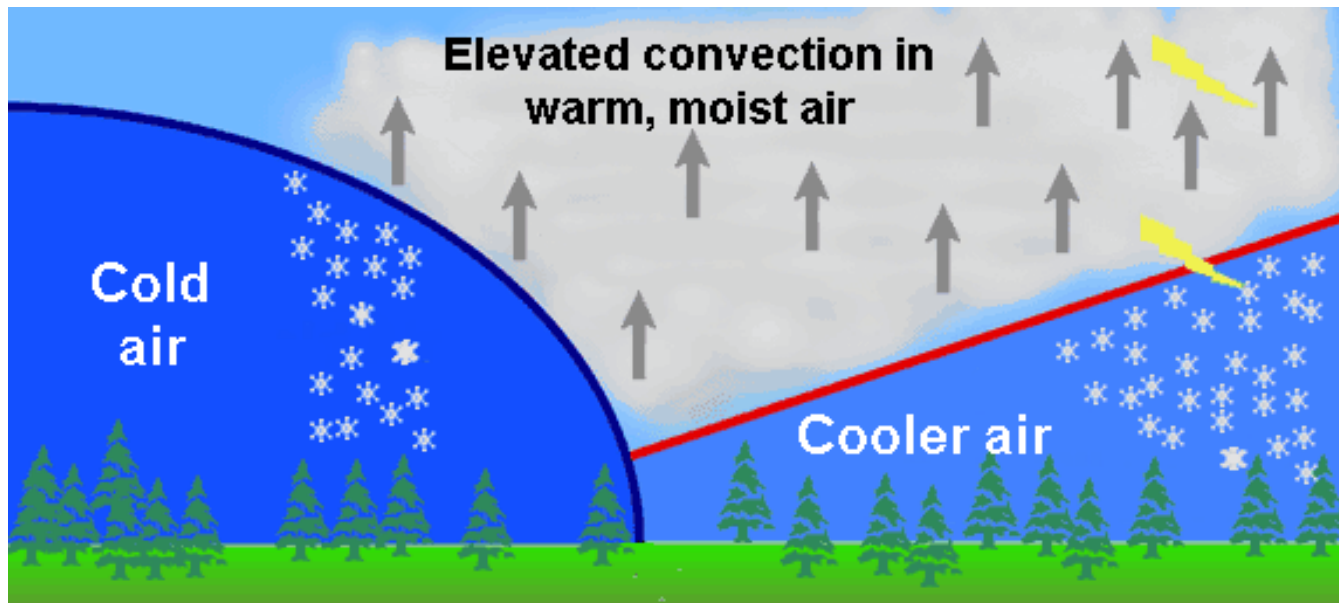

Frost Point: Vapour to Ice

# Example of Deposition in Cold Winter



# What is evaporation?

- ▶ It is a process of making liquid to become gas.

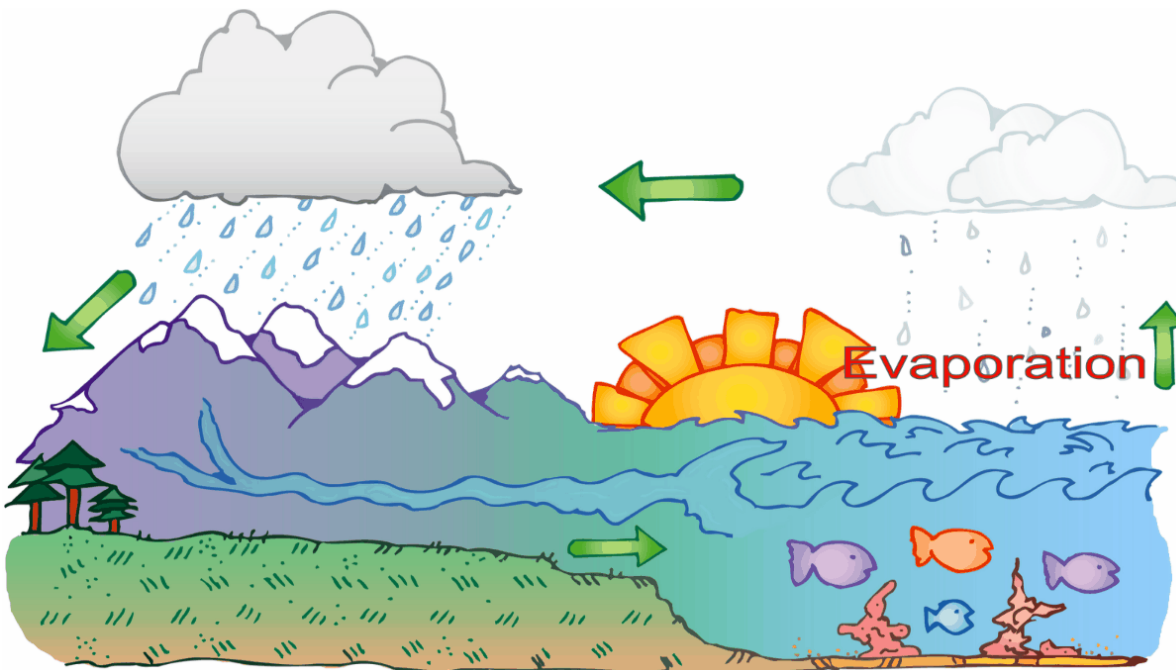
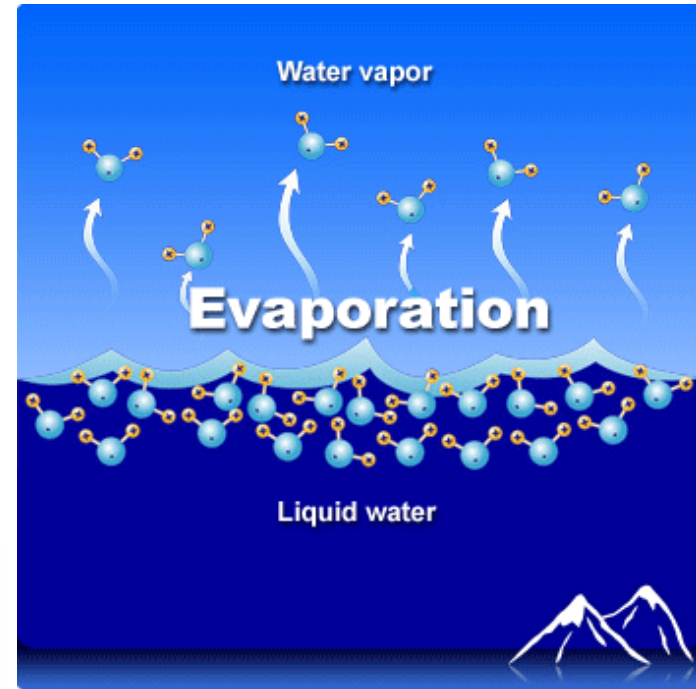

# Example of Evaporation by Animal's Body ...

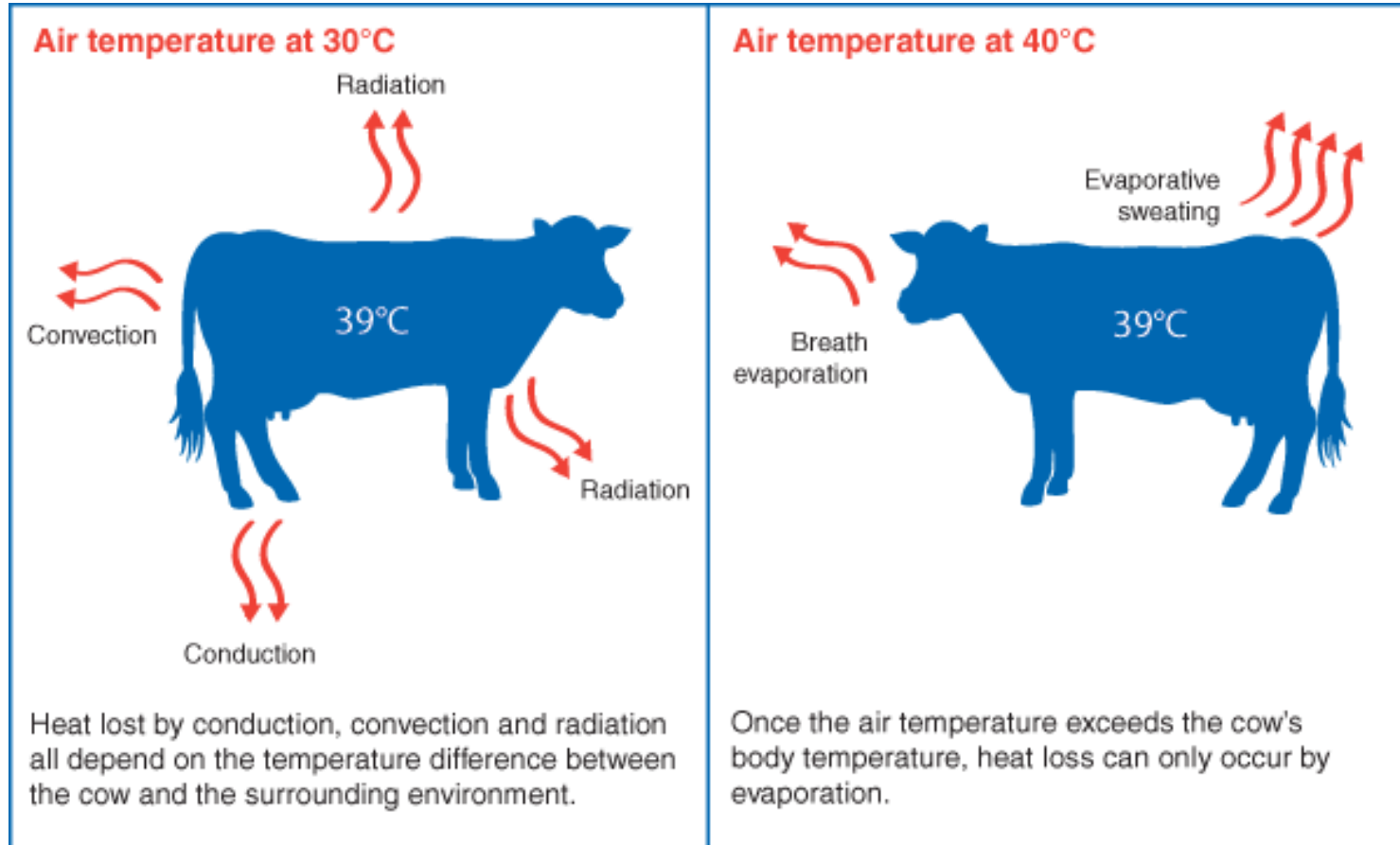

# Understanding Humidity (3)

- Humidity reduces visibility.

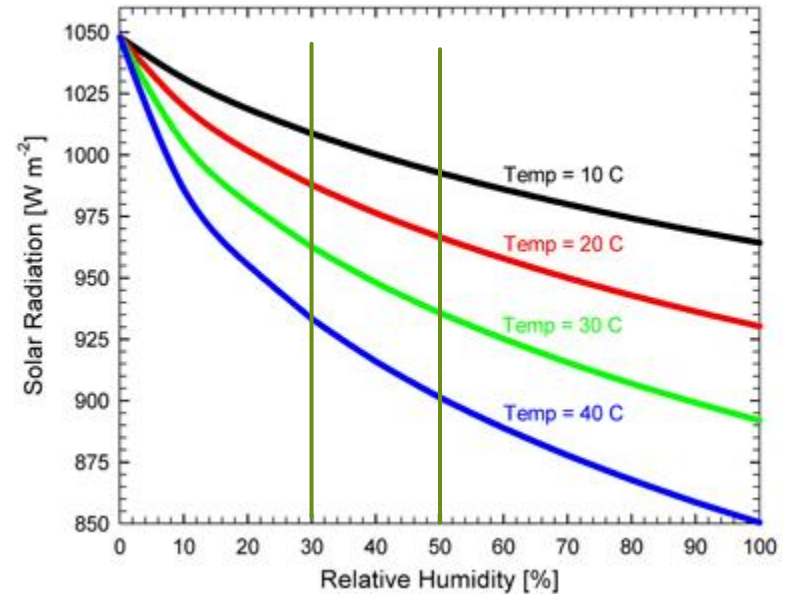

Foggy weather



# Understanding Humidity (4)

- ▶ Water has electrical conductivity.
- ▶ Hence, humidity increases conductivity or reduces electricity resistance.

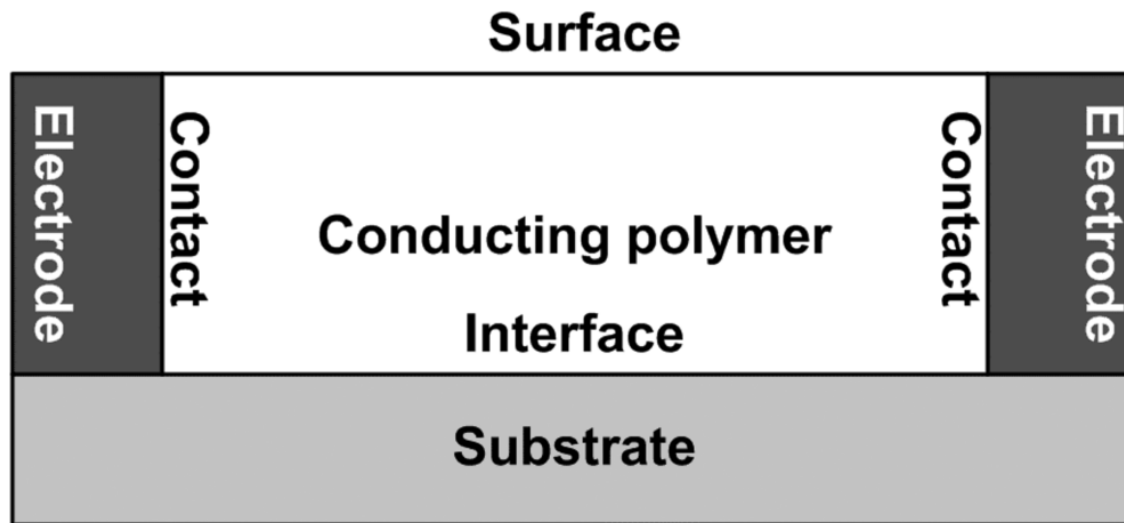

## Humidity Sensitive Resistors

# Understanding Humidity (5)

- ▶ Water has electrical conductivity.
- ▶ Hence, humidity increases the capacity of electricity storage of a conductive plate.

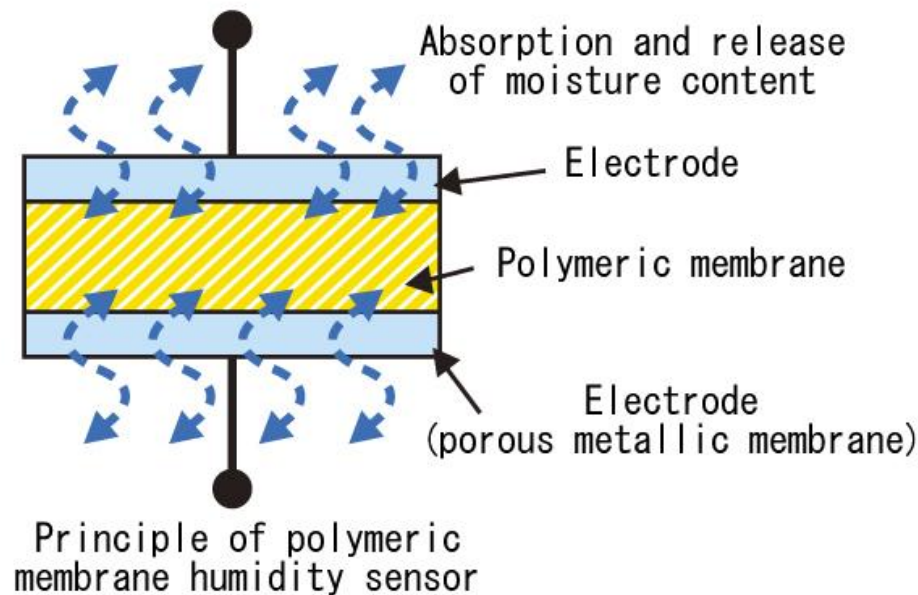

## Humidity Sensitive Capacitors

# Example

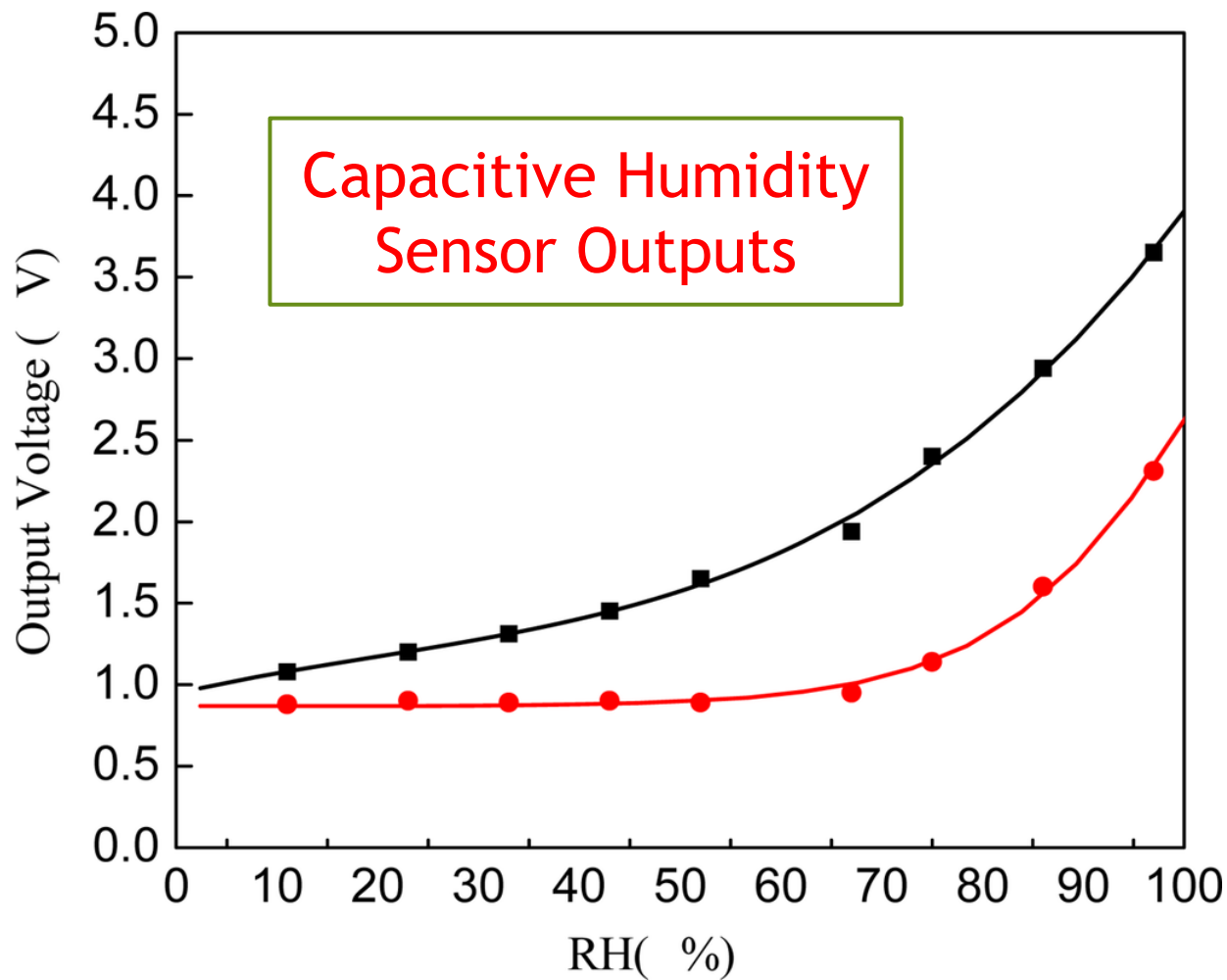

# Definition of Absolute Humidity

- ▶ Absolute humidity is the amount of **mass of water vapour per unit volume** at a specific temperature.

$$\text{Absolute Humidity} = \frac{\text{Mass of Water Vapour}}{\text{Volume}}$$

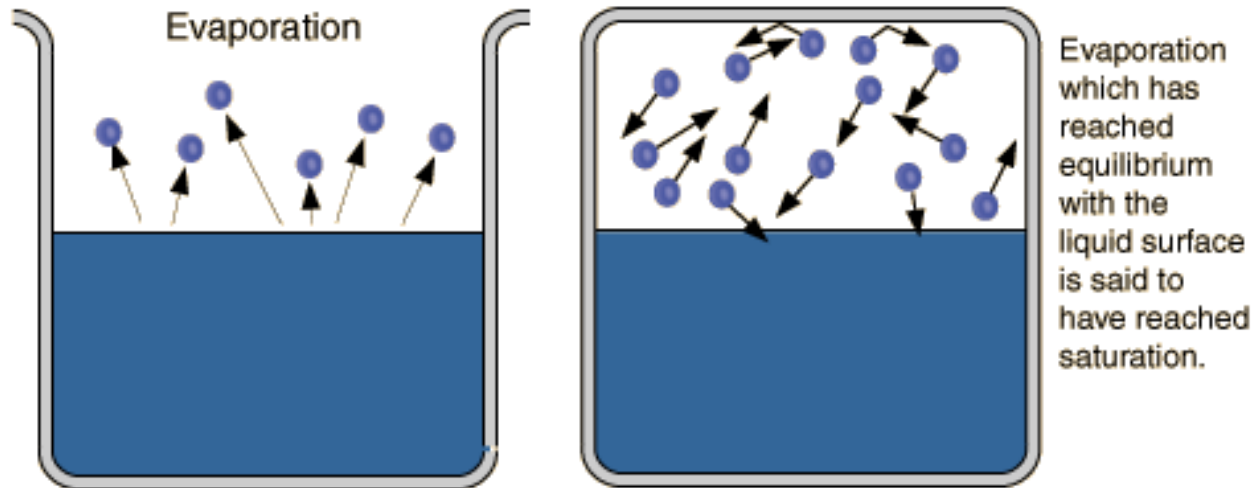

# Equation of Absolute Humidity

- Absolute humidity is the amount of mass of water vapour per unit volume at a specific temperature.

$$PV = nRT$$

$$PV = \frac{m_{\text{vapour}}}{M_{\text{water}}} RT$$

$$H = \frac{m_{\text{vapour}}}{V} = \frac{M_{\text{water}}}{R} \times \frac{P}{T}$$

$M_{\text{water}} = 0.018 \text{ kg/mol}$   
Molar mass of water

$R = 8.31 \text{ J/mol.K}$   
Gas constant

$R = 0.0821 \text{ L.atm/mol.K}$   
Gas constant

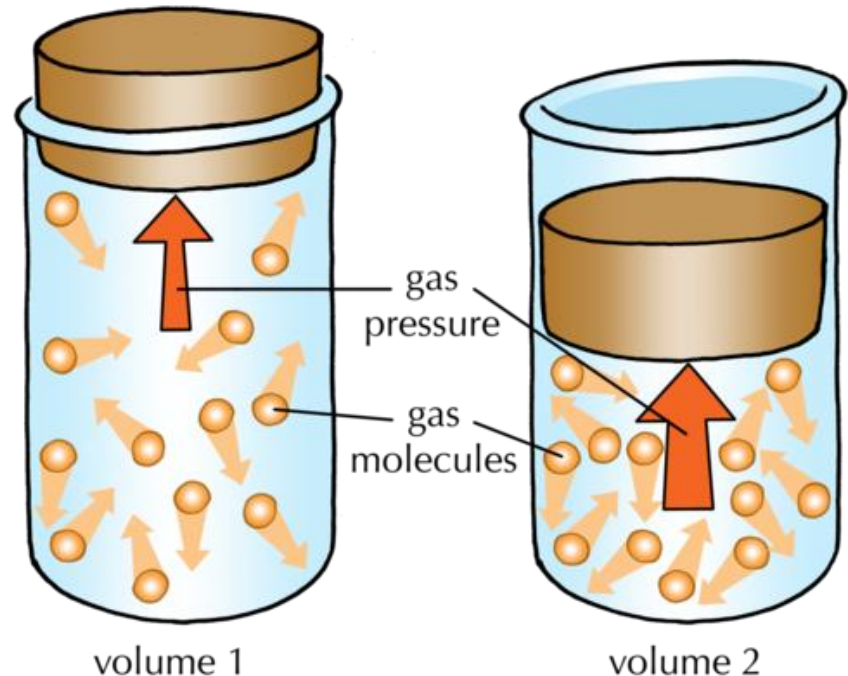

# Definition of Relative Humidity

- ▶ The ratio between the partial pressure of the water vapour and the maximum pressure of the water vapour under the same conditions of volume and temperature is called the relative humidity.

$$RH = \frac{P}{P_{\max}} = \frac{n}{n_{\max}}$$

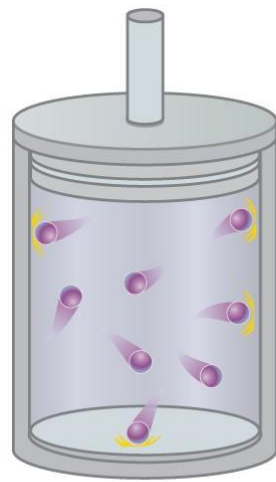

$$PV = nRT$$

Same Volume  
Same Temperature

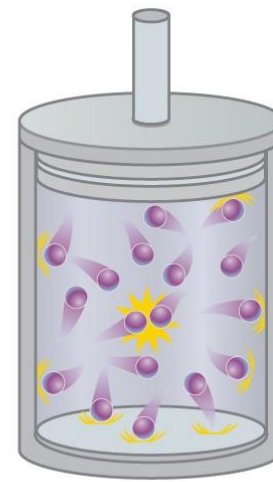

$$P_{\max}V = n_{\max}RT$$

# Equation of Relative Humidity

$$RH = \frac{P}{P_{\max}} = \frac{n}{n_{\max}}$$

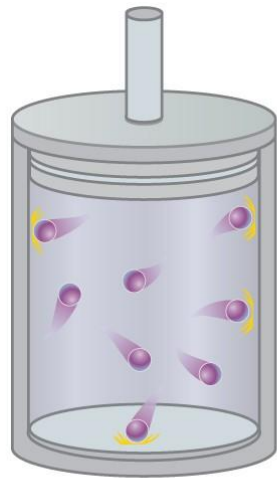

$$PV = nRT$$

Same Volume  
Same Temperature

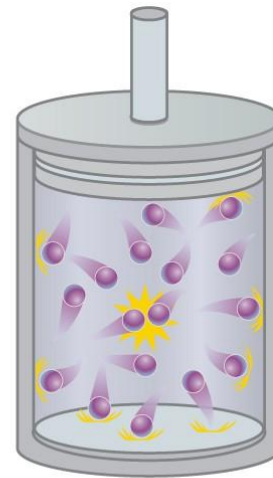

$$P_{\max}V = n_{\max}RT$$

# Example Showing Different RH

$$P_1V = n_1RT$$

$$P_2V = n_2RT$$

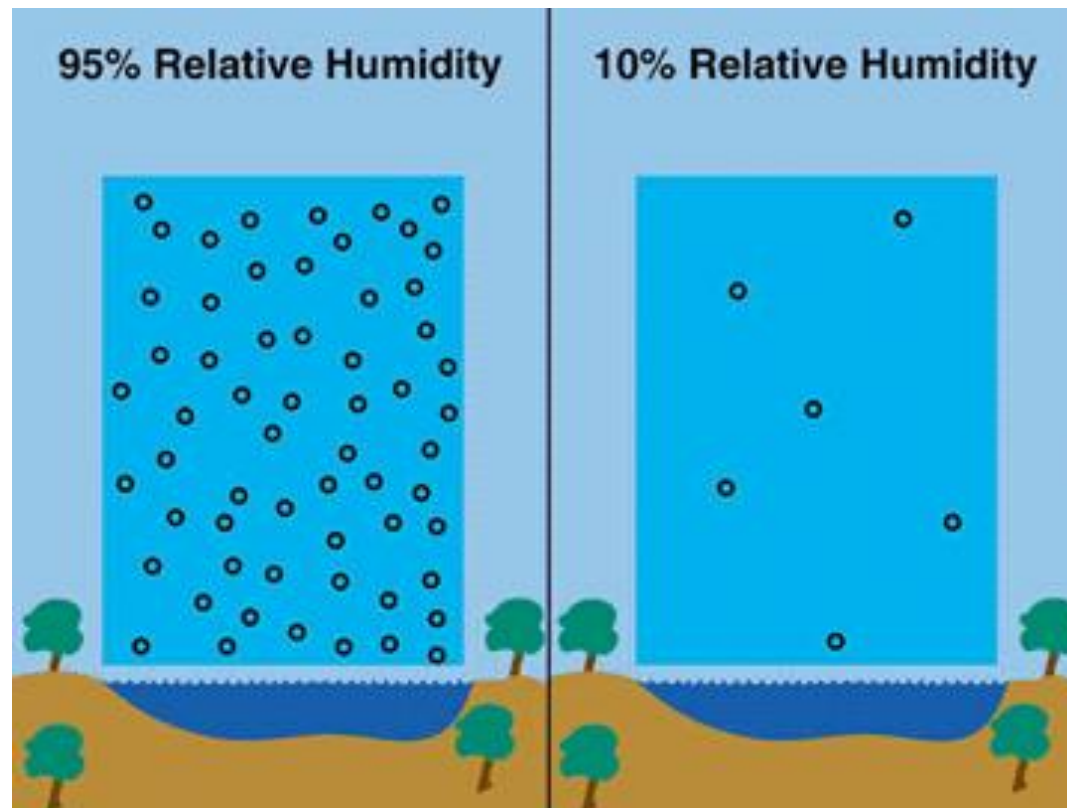

# Exercise

- Explain the phenomenon indicated by the figure below.

- Answer:

$$\begin{matrix} \uparrow & & \uparrow \\ P_{\max} & V = n_{\max} & RT \end{matrix}$$

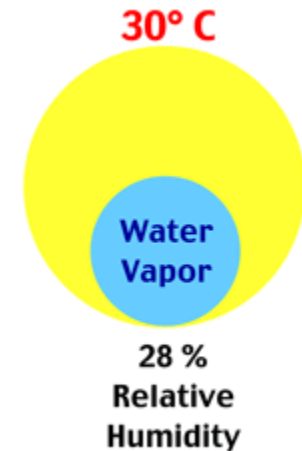
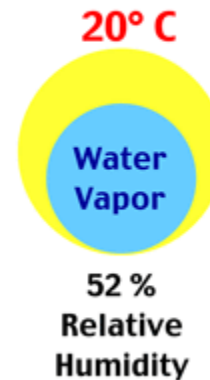

When temperature rises, the maximum pressure increases under the condition of the same maximum mole number. Hence, relative humidity reduces.

# What is the difference between humidity and moisture?

▶ Humidity refers to:

- ▶ The amount of water in the state of gas (i.e. vapor).
- ▶ The presence of water vapor inside a space.

Could we change its moisture level?

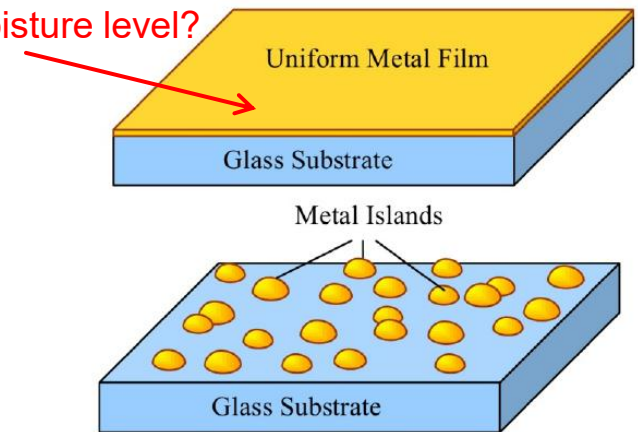

▶ Moisture refers to:

- ▶ The amount of water in the state of liquid.
- ▶ The presence of liquid water inside objects in solid state.

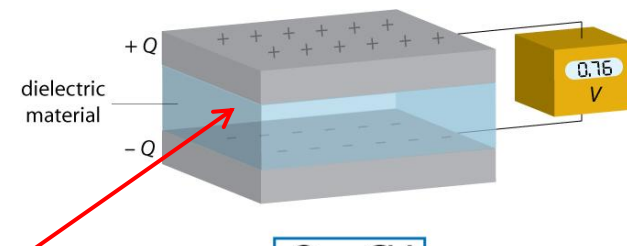

Could we change its moisture level?

$$Q = CV$$

# Outline

- ▶ Understanding of Humidity
- ▶ Computation of Humidity
- ▶ Measurement of Humidity

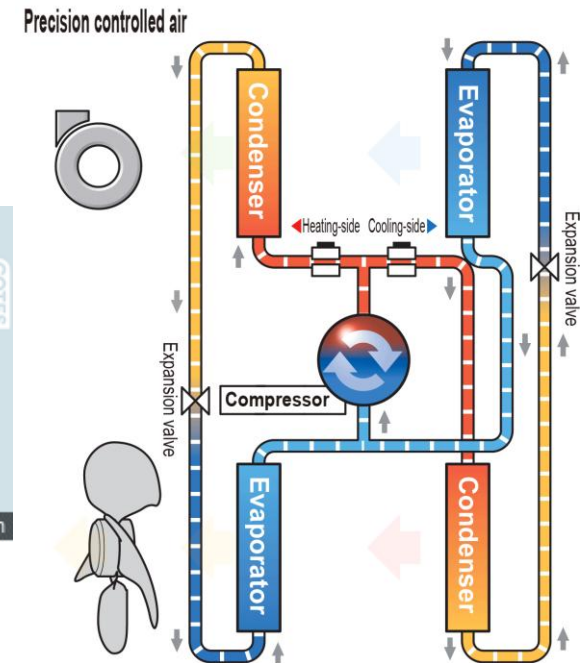
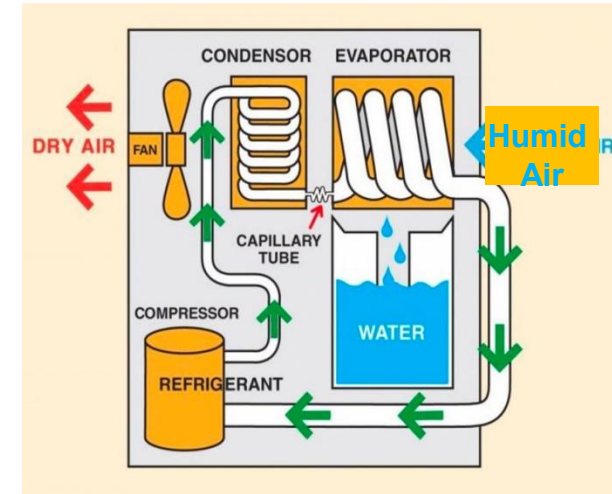
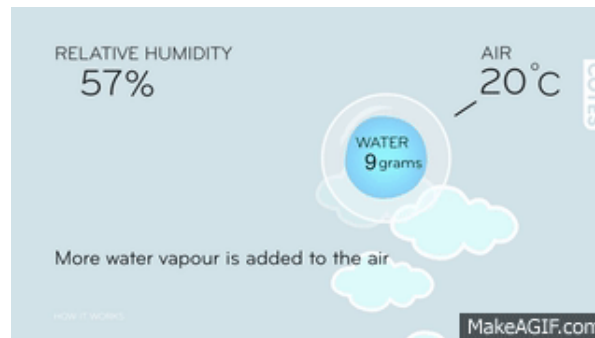
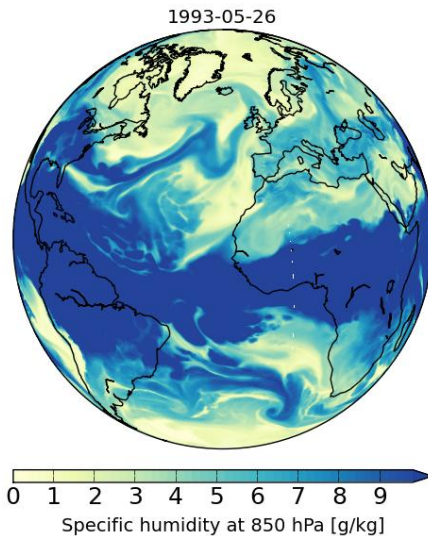

# Example

- As shown in the figure, there is initially 300 g of liquid water and dry air inside a bottle at 0 °C. When the temperature rises to  $t_1 = 20.0$  °C, the mass of liquid water reduces to 295.0 g while the pressure rises to 1.1 atm. When the temperature further rises to  $t_2 = 30.0$  °C, the mass of liquid water reduces to 288.0 g while the pressure rises to 1.3 atm. What are the humidity inside the bottle when the temperatures are at 20.0 °C and 30.0 °C, respectively?

- Answer:

$$H = \frac{m_{\text{vapour}}}{V} = \frac{m_{\text{vapour}}}{nRT} P = \frac{M_{\text{water}}}{R} \times \frac{P}{T}$$

Molar mass of water  
↓

$$H(20^\circ\text{C}) = \frac{0.018}{0.0821} \times \frac{1.1}{273.15 + 20} = 8.23 \times 10^{-4} \text{ kg/L}$$

$$H(30^\circ\text{C}) = \frac{0.018}{0.0821} \times \frac{1.3}{273.15 + 30} = 9.40 \times 10^{-4} \text{ kg/L}$$

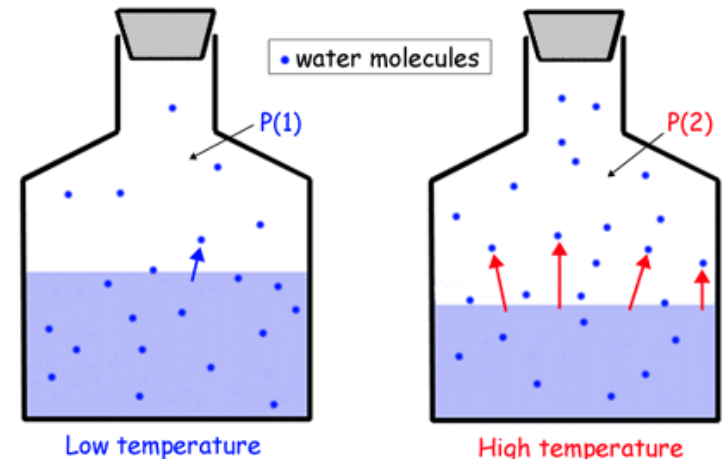

# Example

- ▶ As shown in the figure, the temperature is 25 °C which is kept constant. If the increase of pressure is 0.2 atm, what is the increase of absolute humidity?

- ▶ Answer:

Molar mass of water

$$H = \frac{m_{\text{vapour}}}{V} = \frac{M_{\text{water}}}{R} \times \frac{P}{T}$$

$$\Delta H = \frac{M_{\text{water}}}{R} \times \frac{\Delta P}{T}$$

$$\Delta H = \frac{0.018}{0.0821} \times \frac{0.2}{273.15 + 25} = 1.47 \times 10^{-4} \text{ kg/L}$$

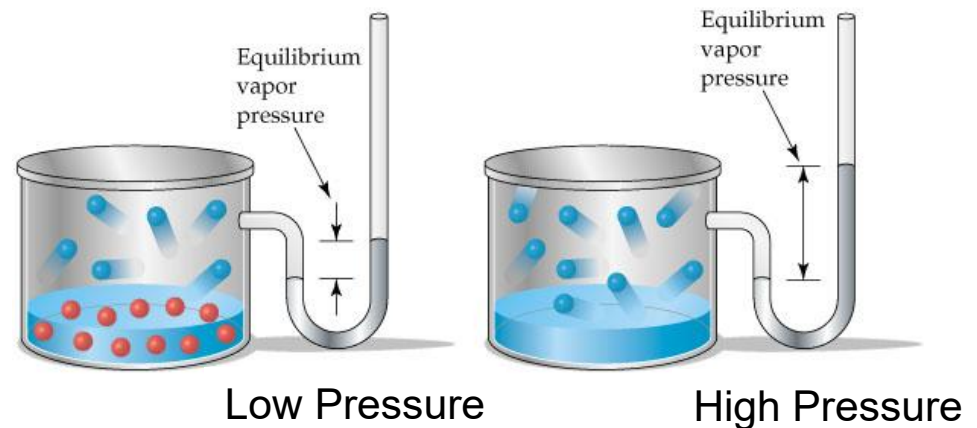

# Example

- ▶ Assume that the air in a room could contain  $30.0\text{g/m}^3$  of water vapour. If the air in the room actually contains  $10.0\text{g/m}^3$  of water vapour, what is the relative humidity of the air?
- ▶ Answer:

$$RH = \frac{P}{P_{\max}} = \frac{n}{n_{\max}}$$

$$\frac{n}{n_{\max}} = \frac{m}{m_{\max}}$$

$$RH = \frac{10}{30} = 33.33\%$$

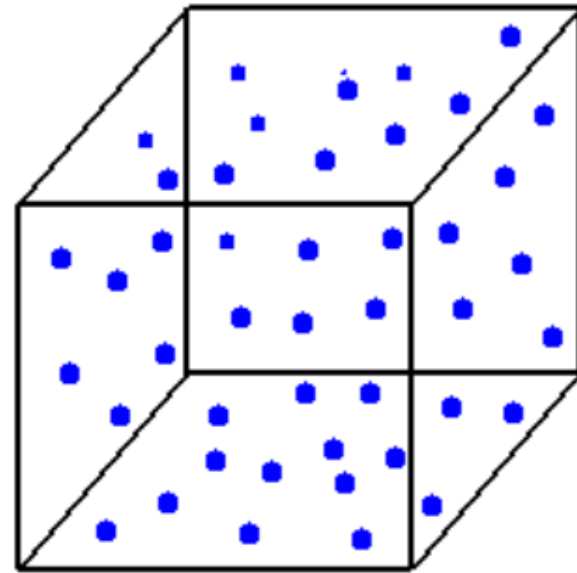

# Example

- ▶ Refer to the figure which is the plot of experimental data with humidity in a room. If the room's temperature now is at 30 °C, what is the percentage of water in the air if the relative humidity is 70%?

▶ Answer:

▶ 3.0%

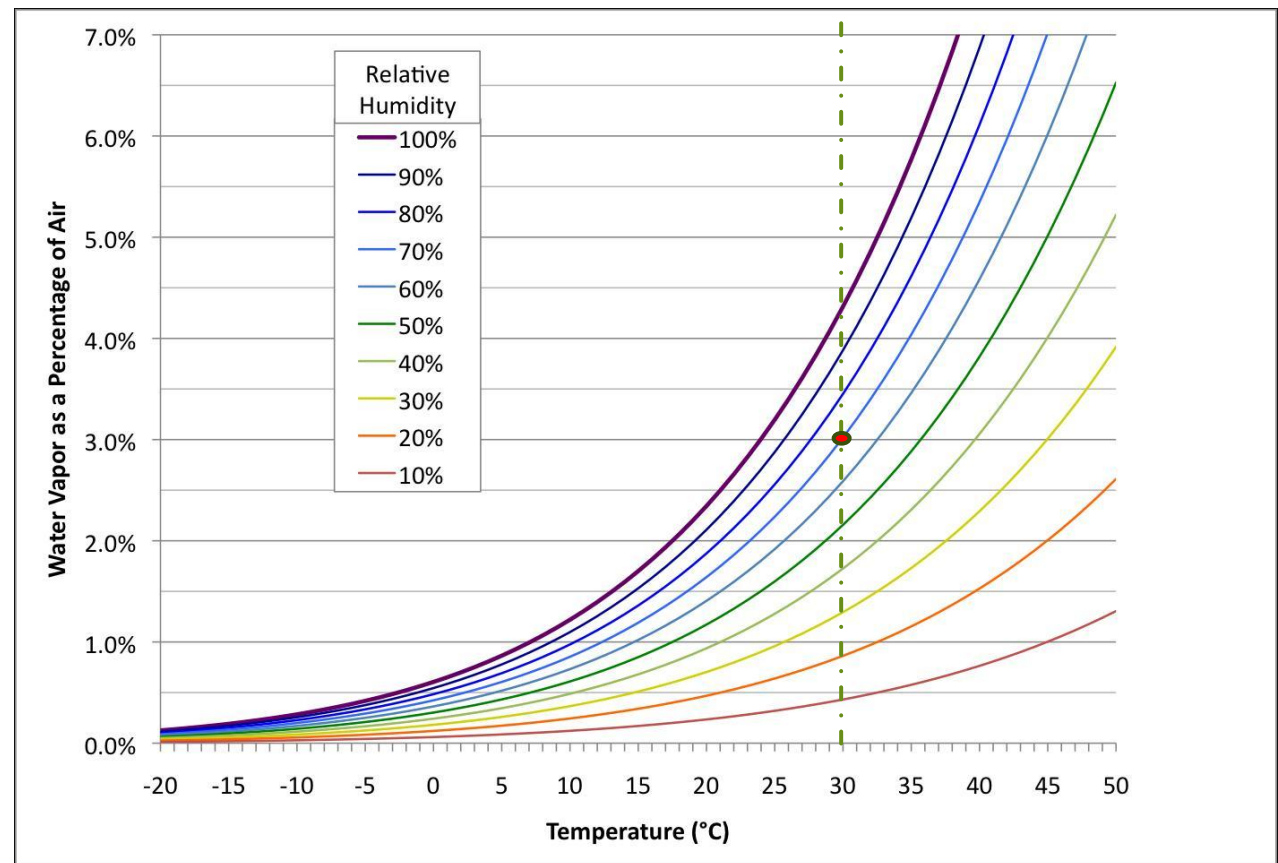

# Outline

- ▶ Understanding of Humidity
- ▶ Computation of Humidity
- ▶ Measurement of Humidity

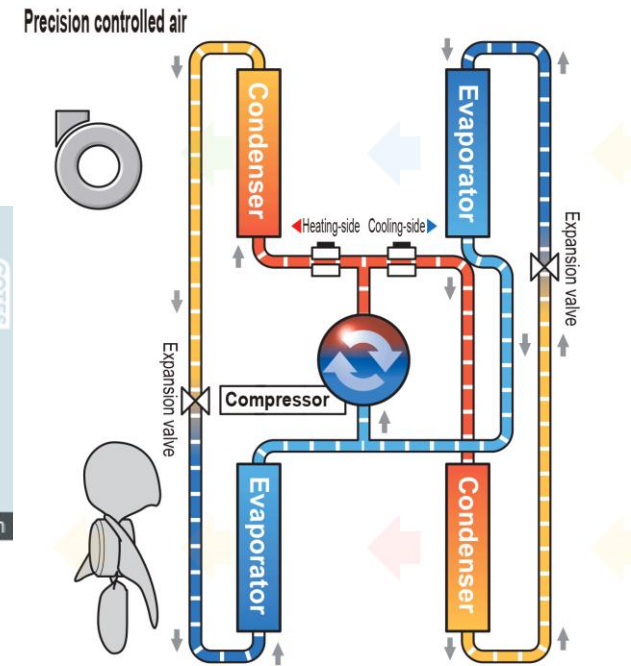
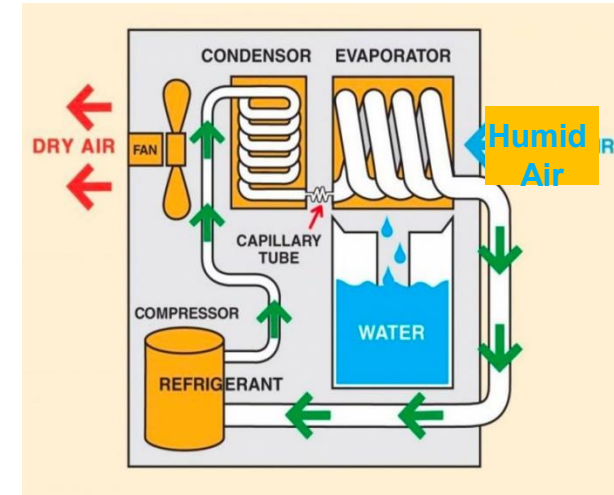
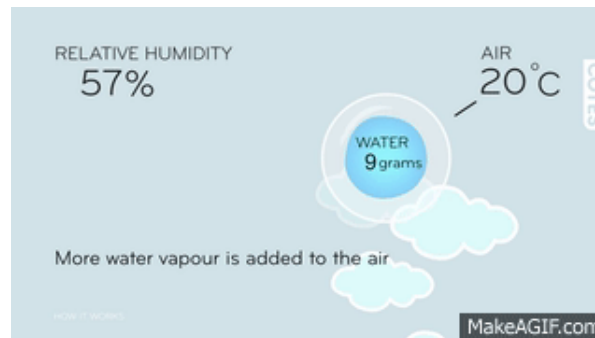
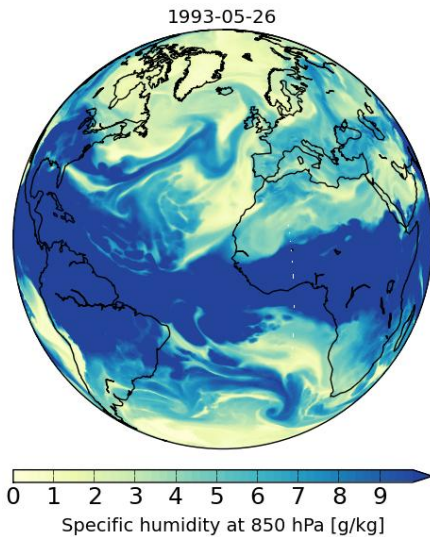

# Humidity Control in Agriculture ...

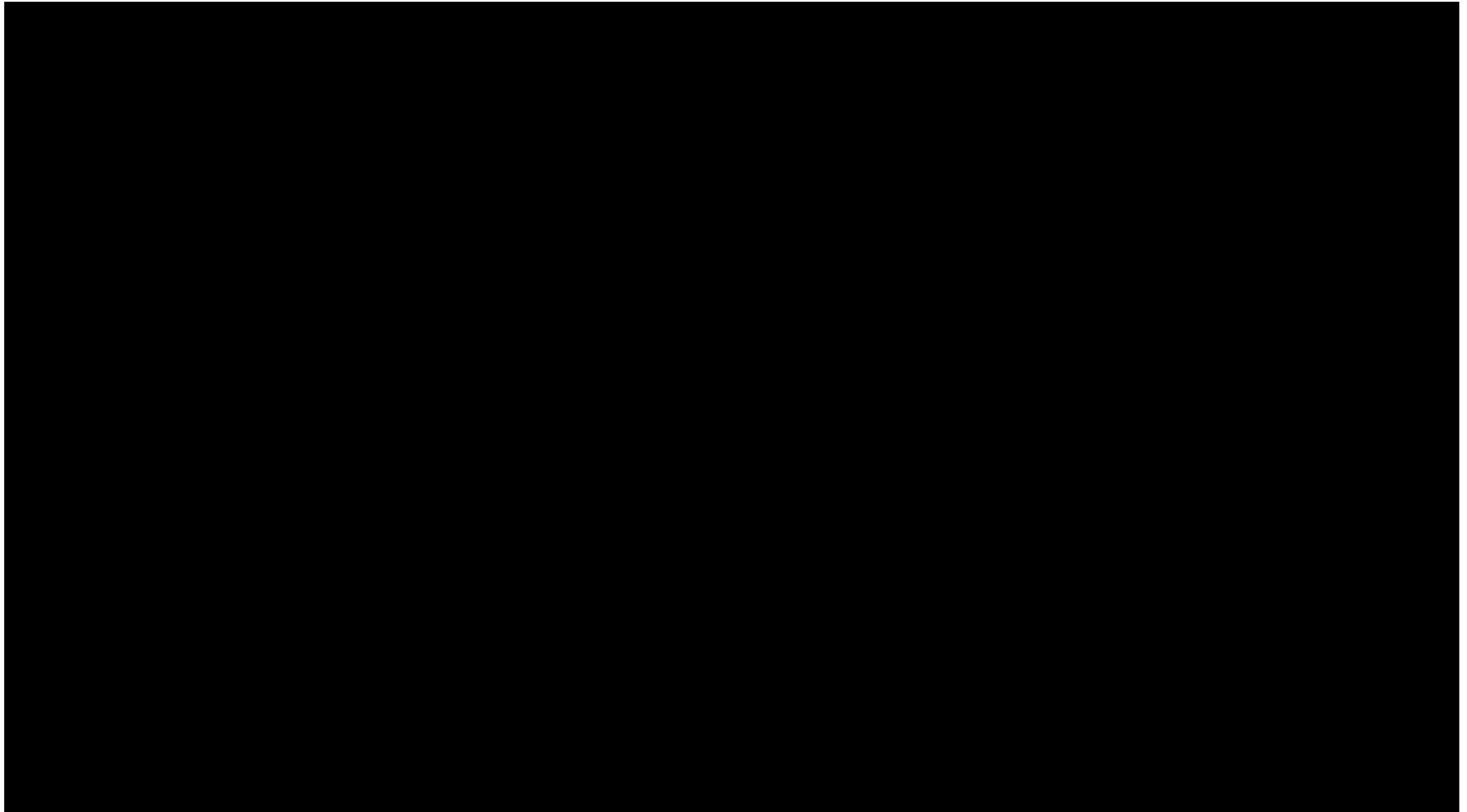

# Humidity Control in Agriculture ...

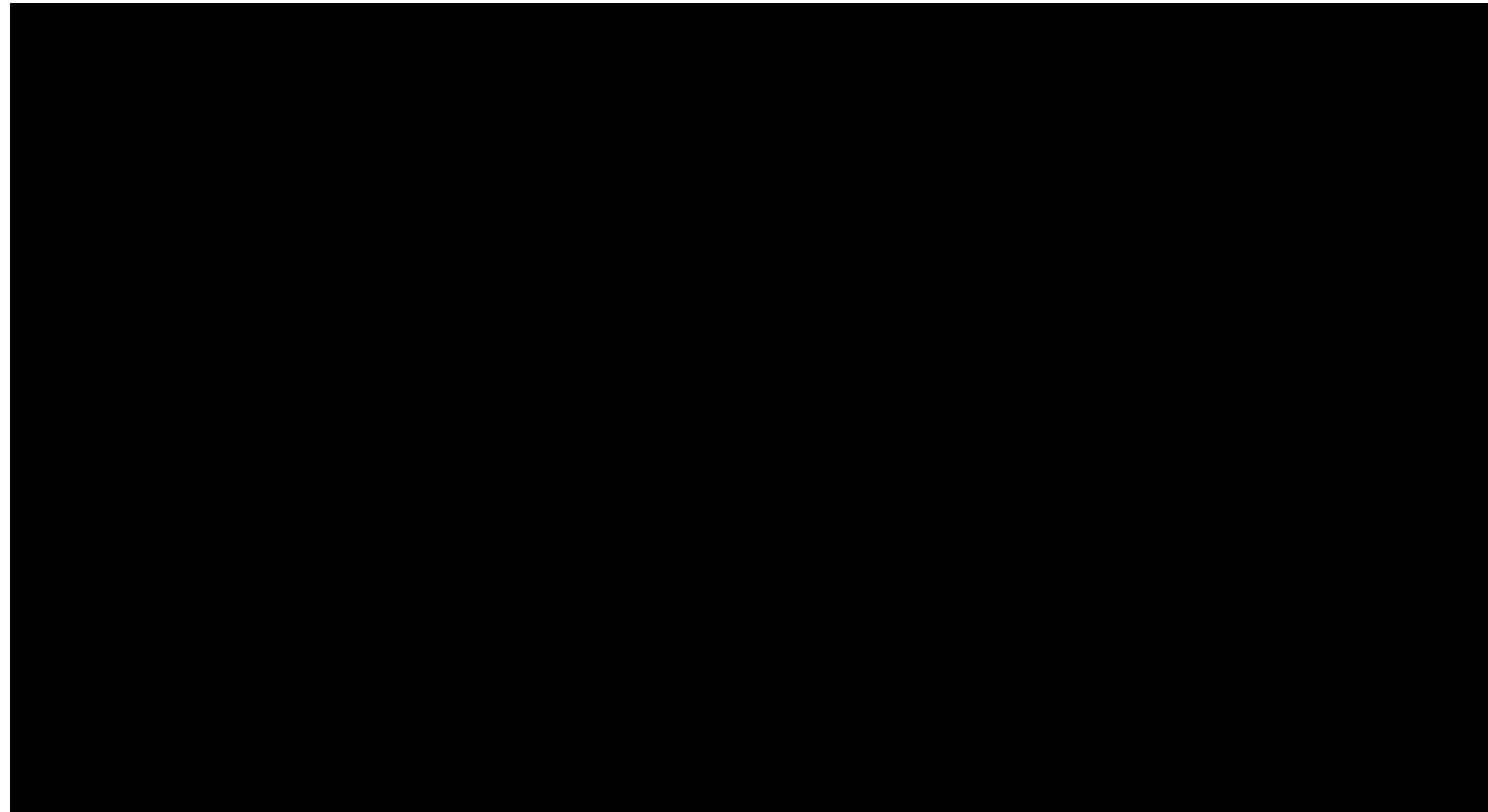

# Humidity Control at Home ...

Reducing humidity at the source  
Improving indoor ventilation  
Dehumidifying  
Improving window thermal efficiency  
prevent condensation

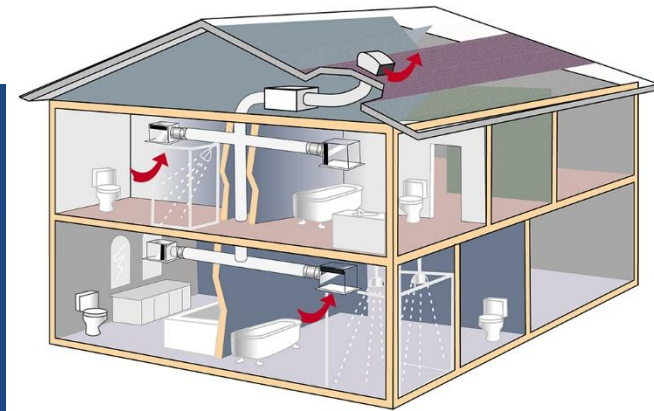

# Humidity Control in Industry ...



# Principles of Measurement

- ▶ **Principle 1:** Humidity could change the moisture level of conductive materials, which will change their **resistance** level. Resistance could be converted into DC voltage which could be automatically measured.
- ▶ **Principle 2:** Humidity could change the moisture level of the dielectric materials inside capacitors, which will change their **capacitances**. Capacitance could be converted into DC voltage which could be measured.

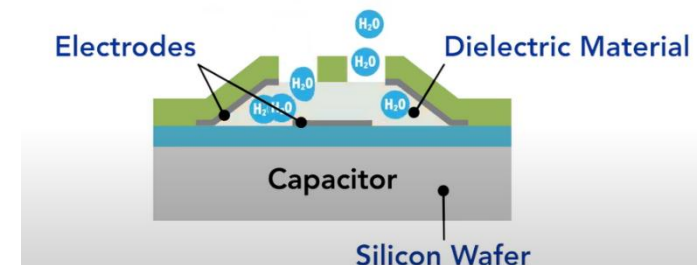
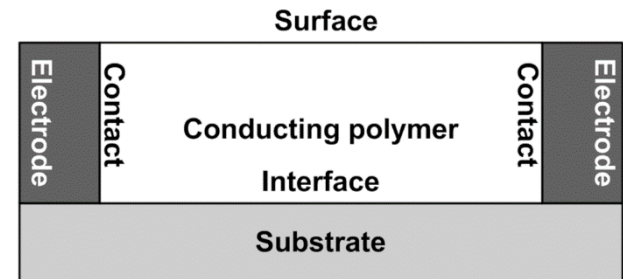

# How to apply principle 1 to design digital measurement and sensing systems for humidity?

- ▶ Humidity is converted to resistance which is then converted to voltage. Finally, the voltage is measured by digital voltmeter (e.g. microcontrollers).

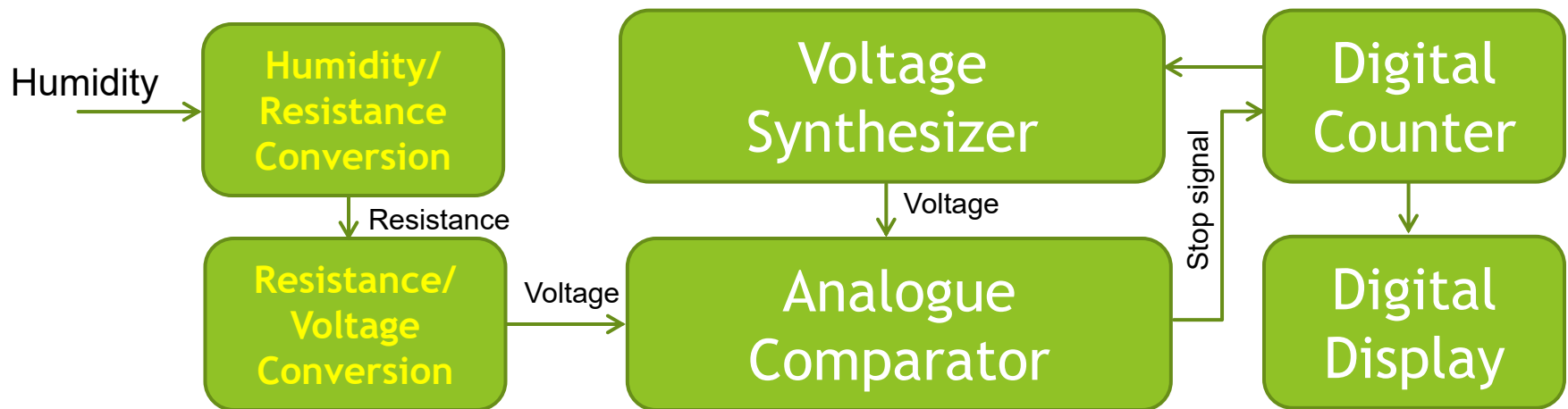

All microcontrollers are programmable digital sensors of voltage!

# How to convert humidity to resistance?

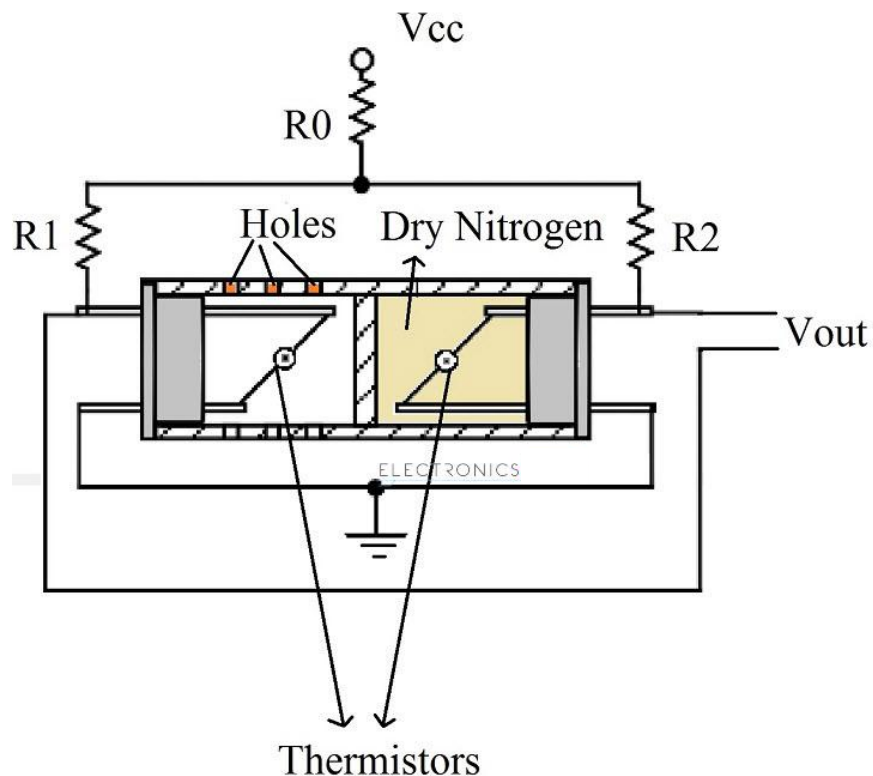

- Humidity to moisture
- Moisture to resistance

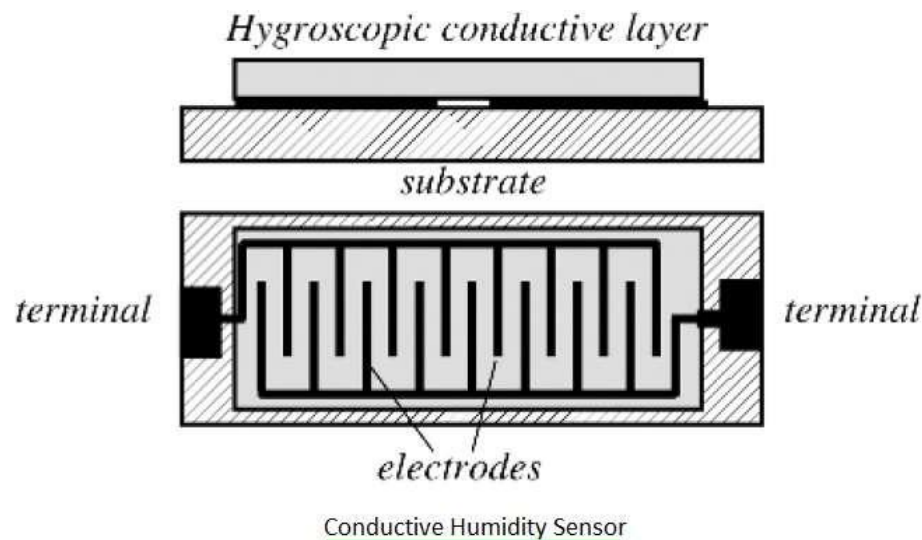

# Example of Sensor Design ...

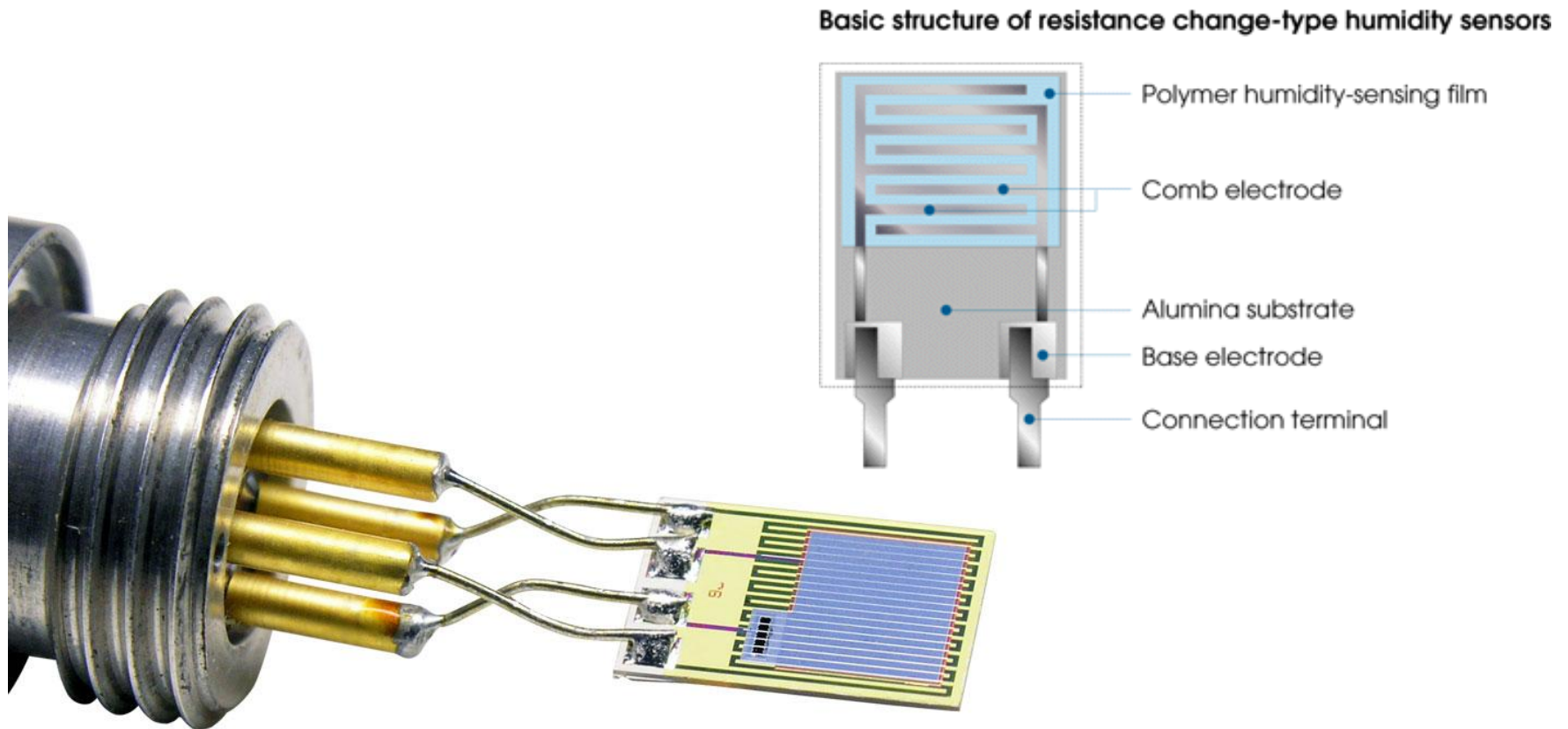

# Example of Implementation ...

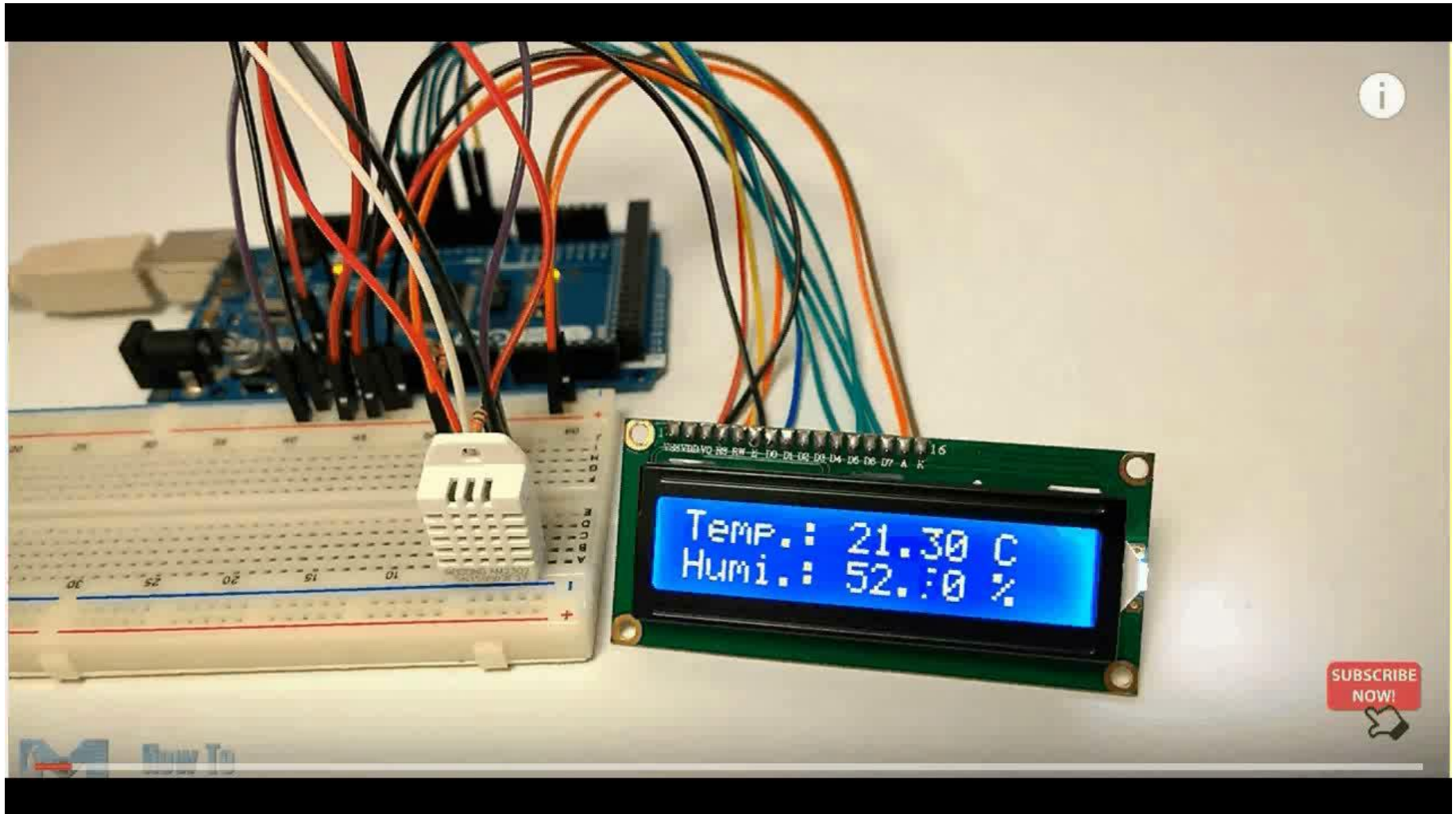

# Example of Application

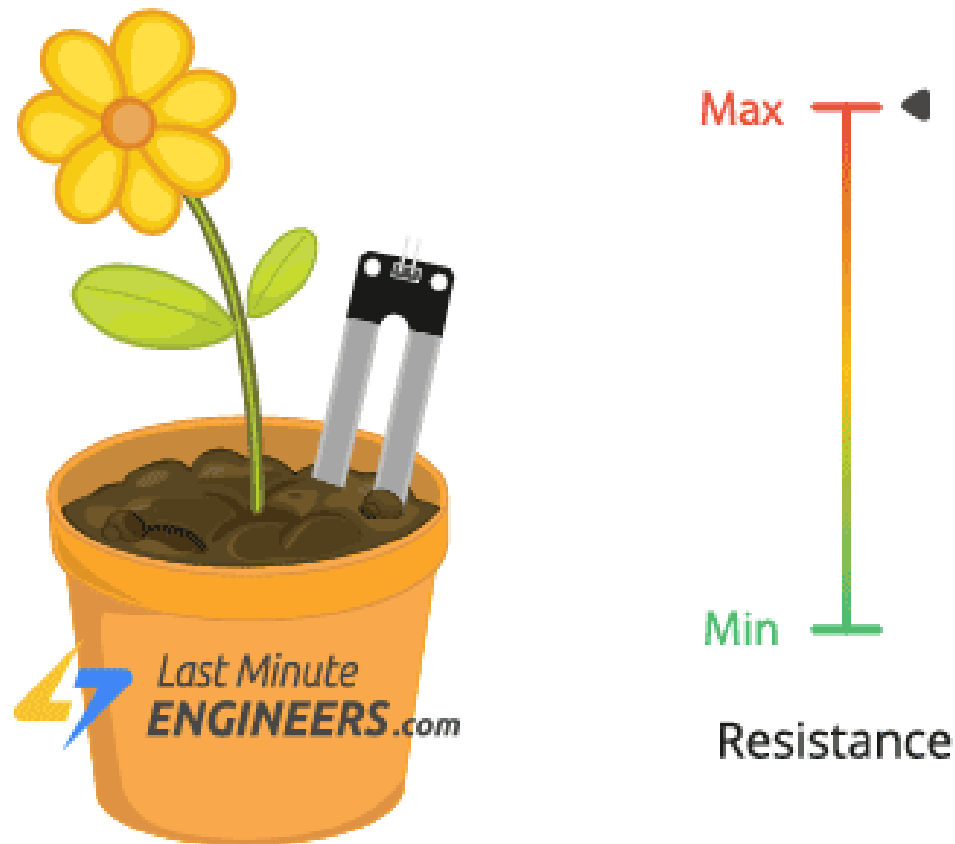

# How to apply principle 2 to design digital measurement and sensing systems for humidity?

- ▶ Humidity is converted to capacitance which is then converted to voltage. Finally, the voltage is measured by digital voltmeter (e.g. microcontrollers).

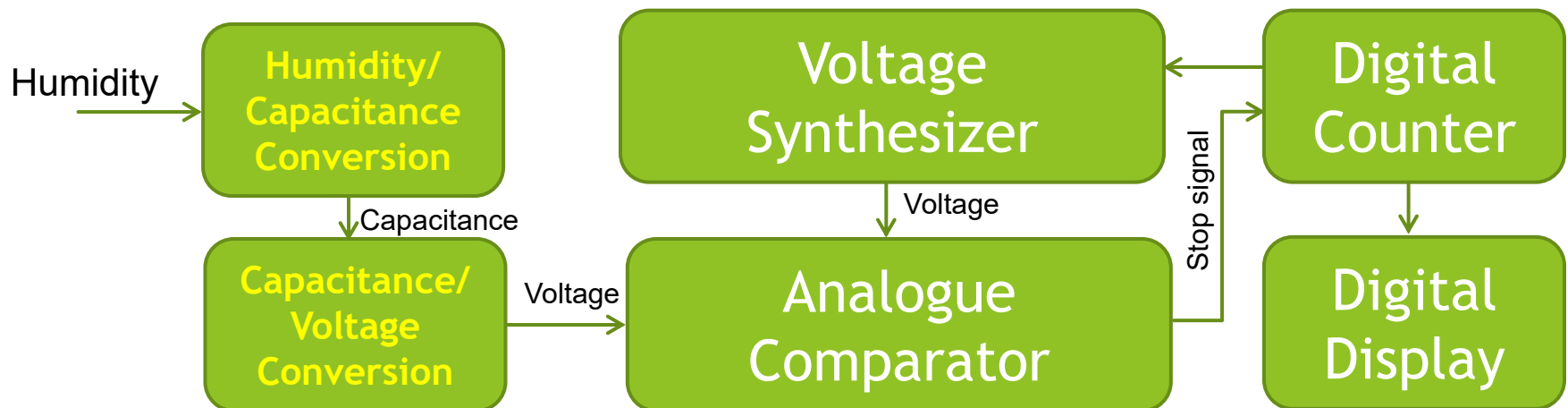

All microcontrollers are programmable digital sensors of voltage!

# How to convert humidity to capacitance?

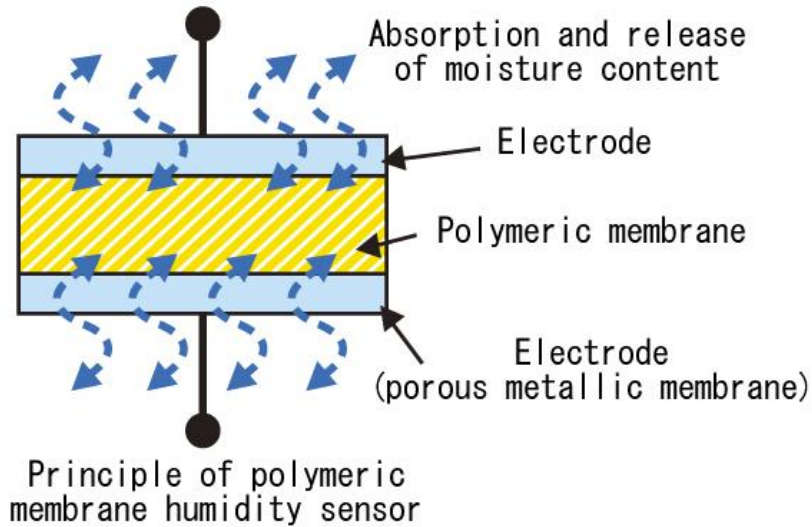

- Humidity to moisture
- Moisture to capacitance

## Humidity sensor

→ Principle

- (1) Water vapor permeably electrode
- (2) Humidity sensitive polymer
- (3) Backplate electrode
- (4) Basesubstrat
- (5) Pin – capacitive measurement
- (6) Pin – temperature measurement

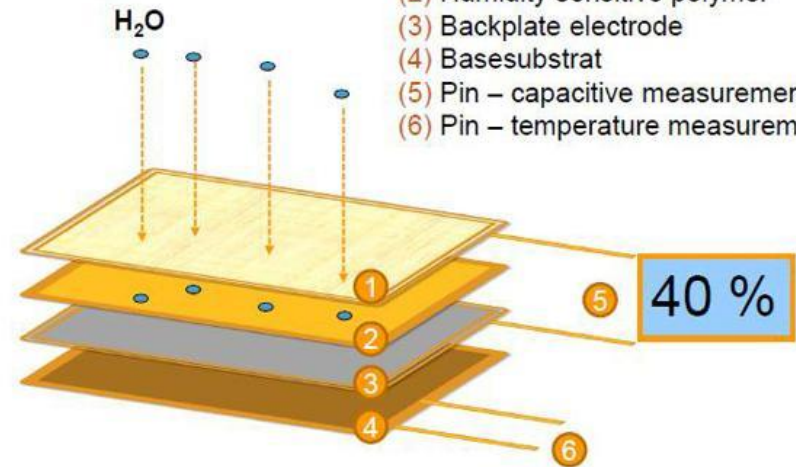

# Example of Application



# Other Principles ...

## Metal paper foil type

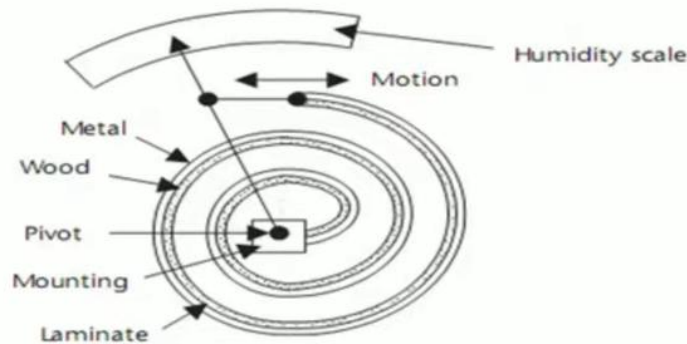

- Humidity to moisture
- Moisture to expansion
- Expansion to resistance  
or
- Expansion to capacitance

## Hair tension Hygrometer

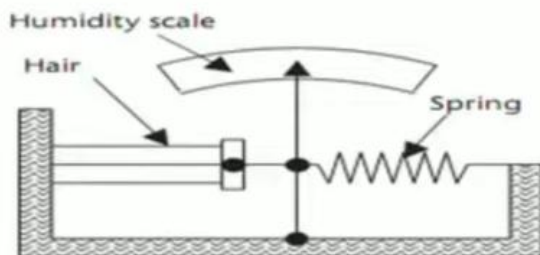

# Remember to Do Calibration

- ▶ Curve fitting for calibration:
  - ▶  $Y_i$  is produced by  $X_i$
  - ▶  $Z_i$  is computed from  $Y_i$
  - ▶  $Z_i$  must be equal to  $X_i$

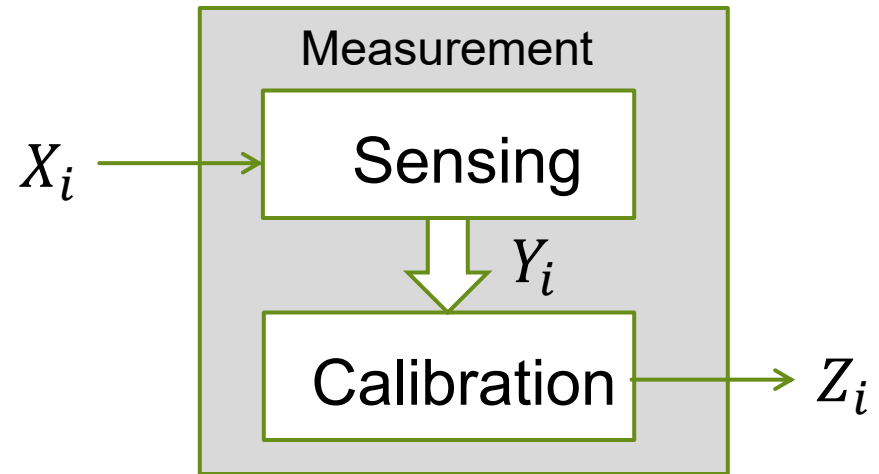

Calibrated Values  $Z_i$

Measured Values  $Y_i$

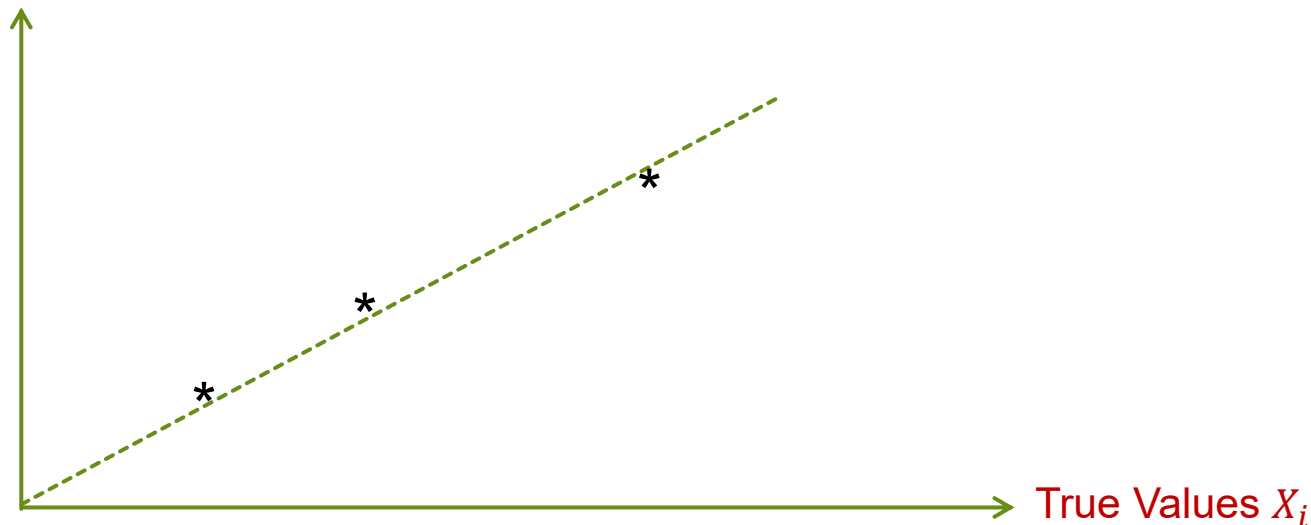

# Example of Calibration Setup

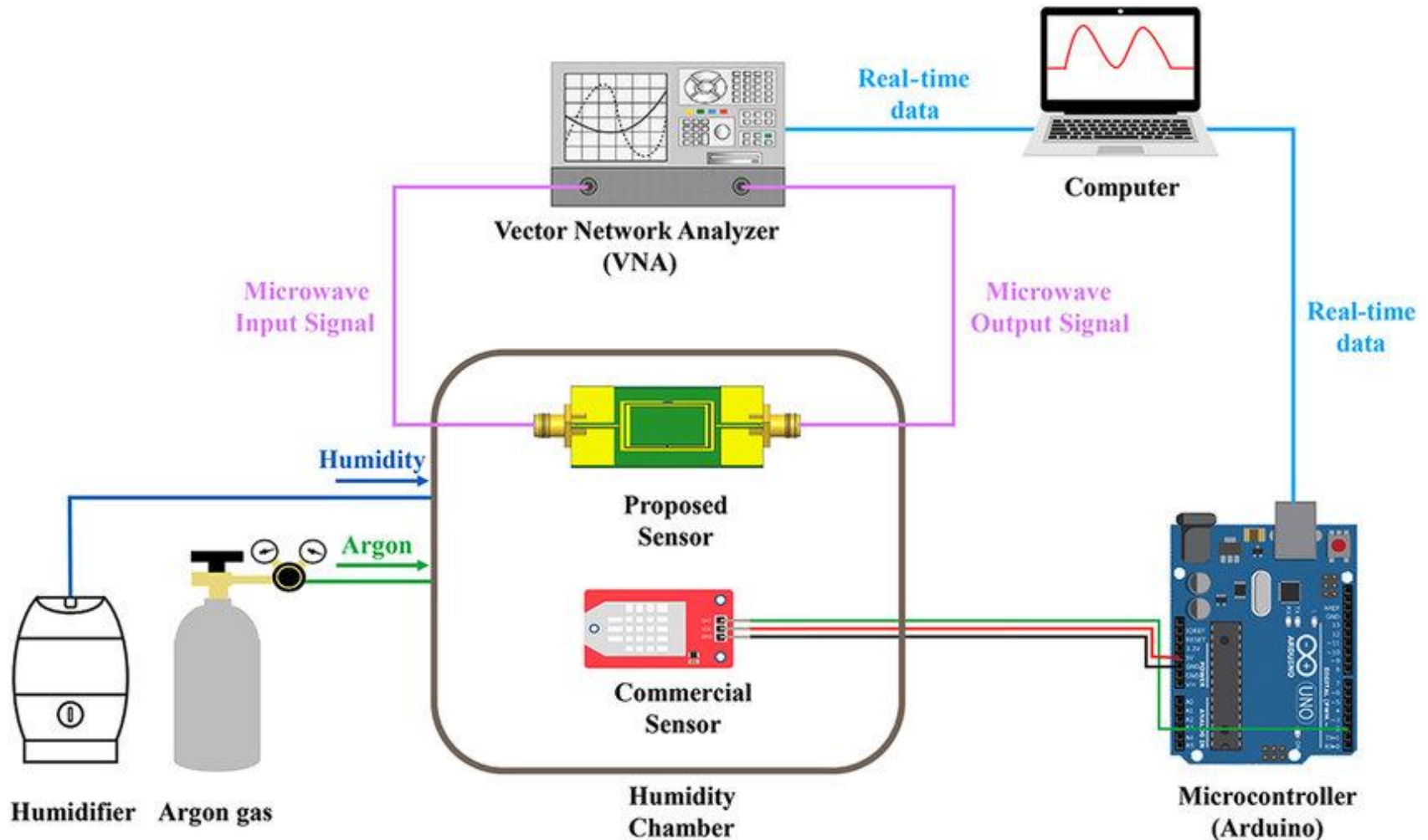

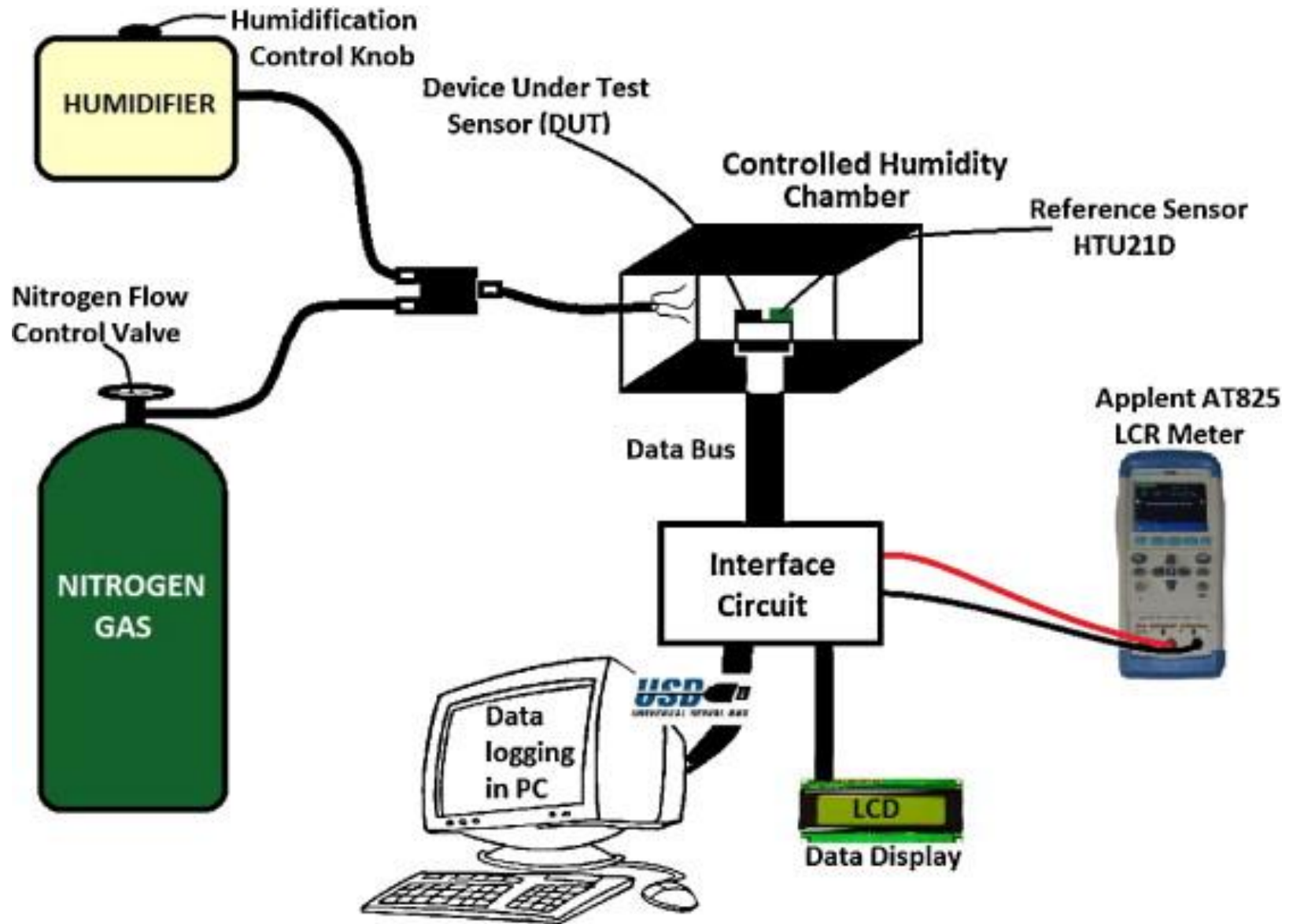

# Remember to Do Error Analysis

- ▶ Systematic error = mean value - true value
- ▶ Repeatability error = value with maximum error - mean value
- ▶ Accuracy = value with minimum error - mean value
- ▶ Hysteresis error = |measured value in increasing - measured value in decreasing|

For each true value, we can do error analysis

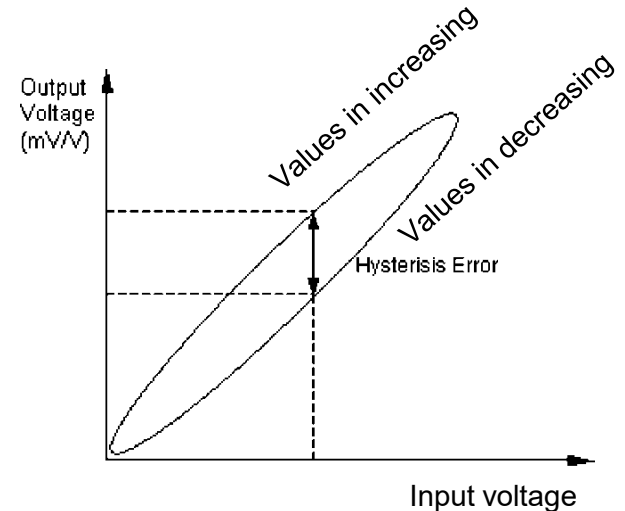
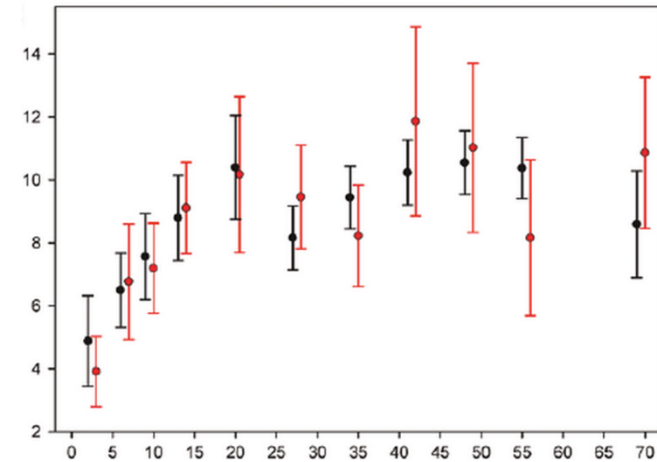

# Summary

- ▶ Understanding of Humidity
- ▶ Computation of Humidity
- ▶ Measurement of Humidity

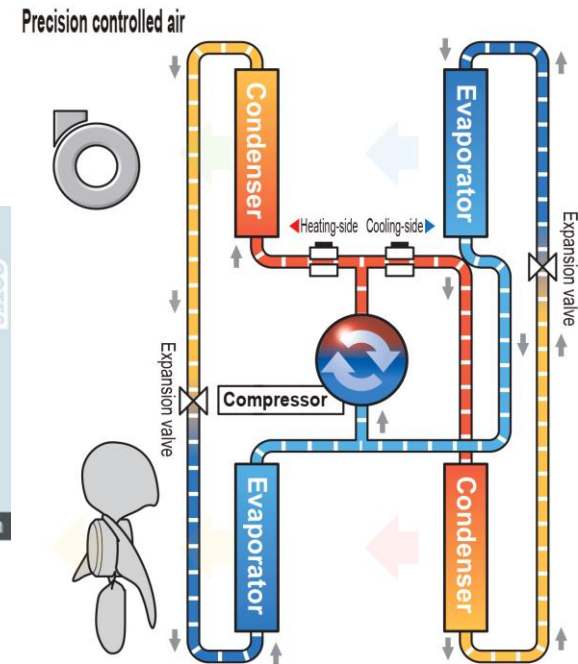
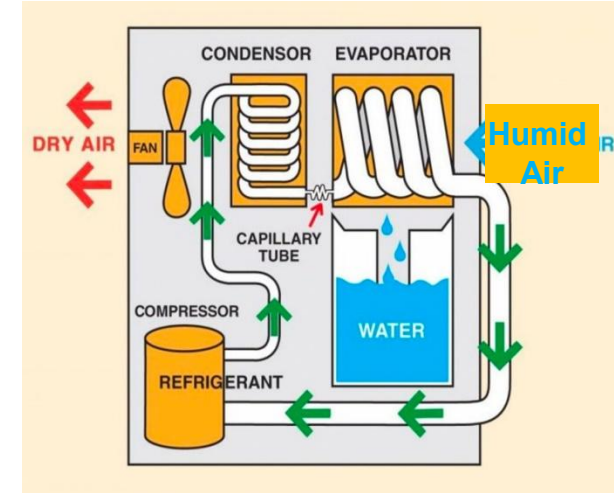
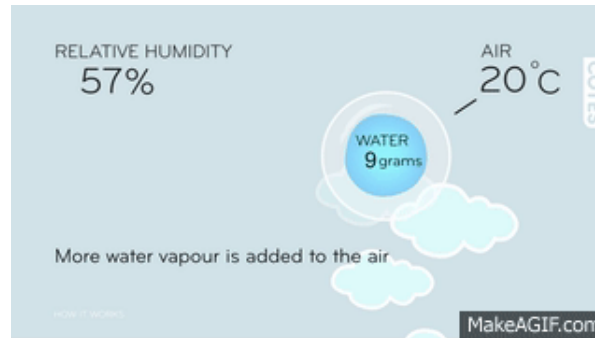
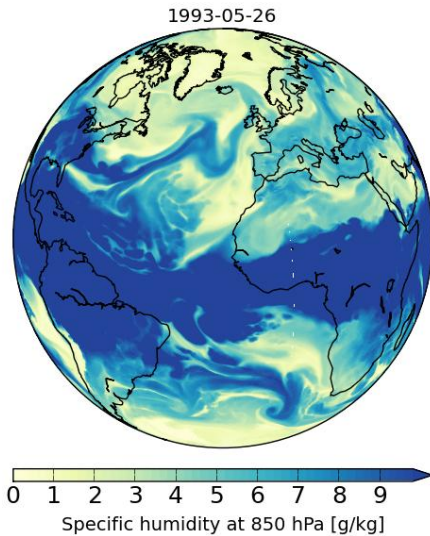

# Outline of Module 4

- ▶ Lecture 1:
  - ▶ Measurement of Pressure
- ▶ Lecture 2:
  - ▶ Measurement of Temperature
- ▶ Lecture 3:
  - ▶ Measurement of Humidity
- ▶ Lecture 4:
  - ▶ Measurement of Vibration
- ▶ Lecture 5:
  - ▶ Measurement of Air Quality

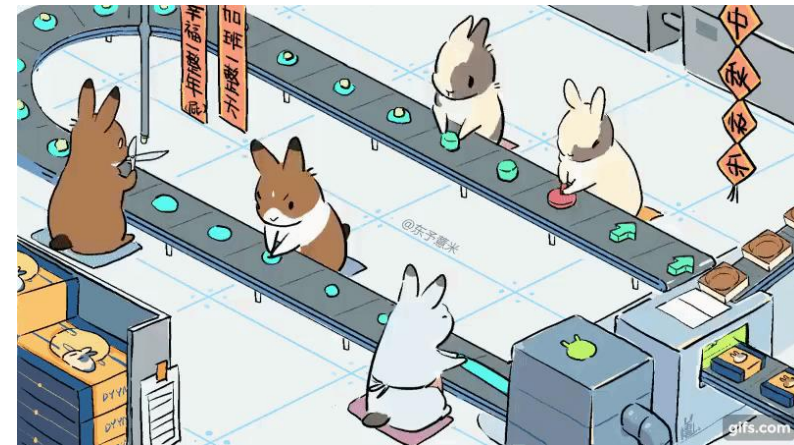



**NANYANG  
TECHNOLOGICAL  
UNIVERSITY**

**School of Mechanical & Aerospace Engineering**

Design, Machine, Control, Intelligence

Module 4 Lecture 4

MA4822

# Measurement of Vibration

Xie Ming, PhD (France)

[mmxie@ntu.edu.sg](mailto:mmxie@ntu.edu.sg)

<http://personal.ntu.edu.sg/mmxie>

# Outline

- ▶ Understanding of Vibration
- ▶ Computation of Vibration
- ▶ Measurement of Vibration

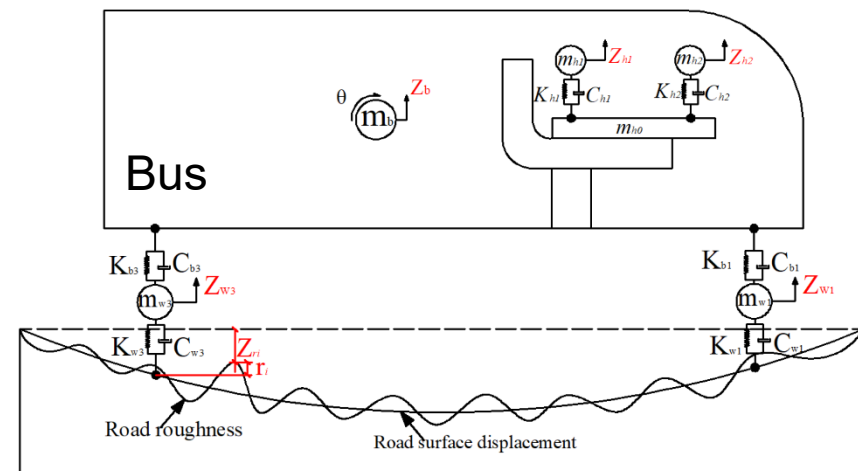

# Outline

- ▶ Understanding of Vibration
- ▶ Computation of Vibration
- ▶ Measurement of Vibration

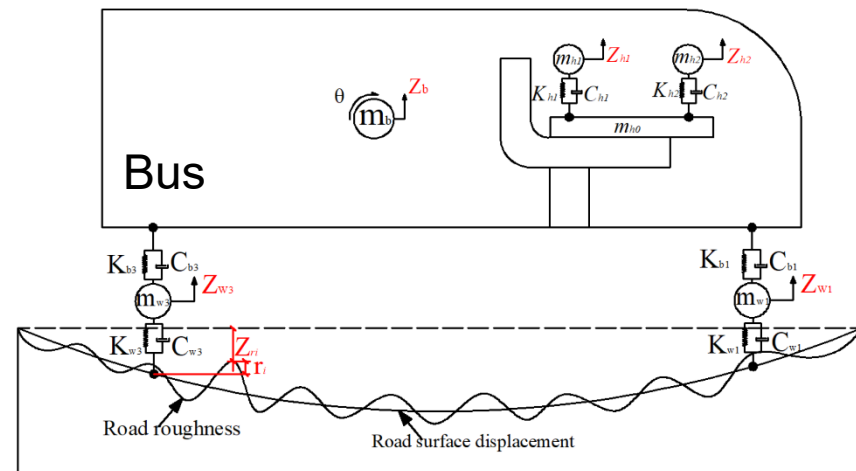
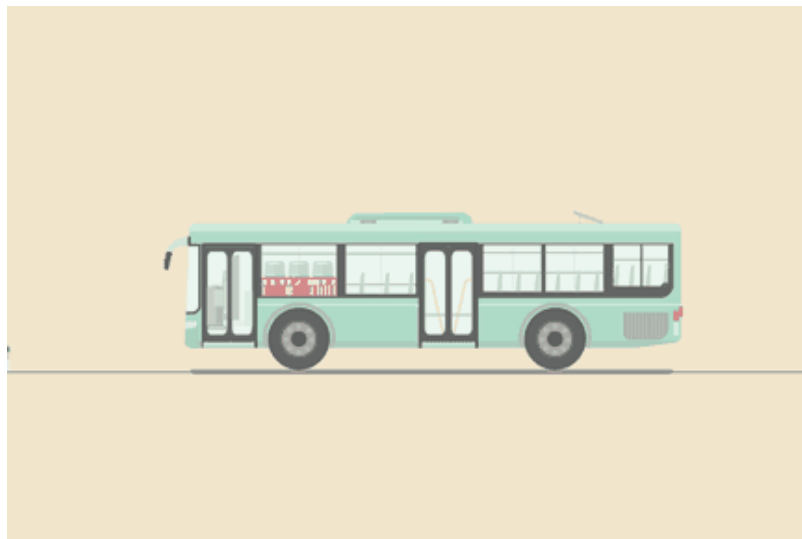

# Importance of Vibration ...

- ▶ In mechanical engineering, we talk about **vibrations**.
- ▶ In electrical engineering, we talk about **oscillations**
- ▶ In mathematics, we talk about **sine waves**.
- ▶ They share the same meanings.
- ▶ All signals are the sums of sine waves.

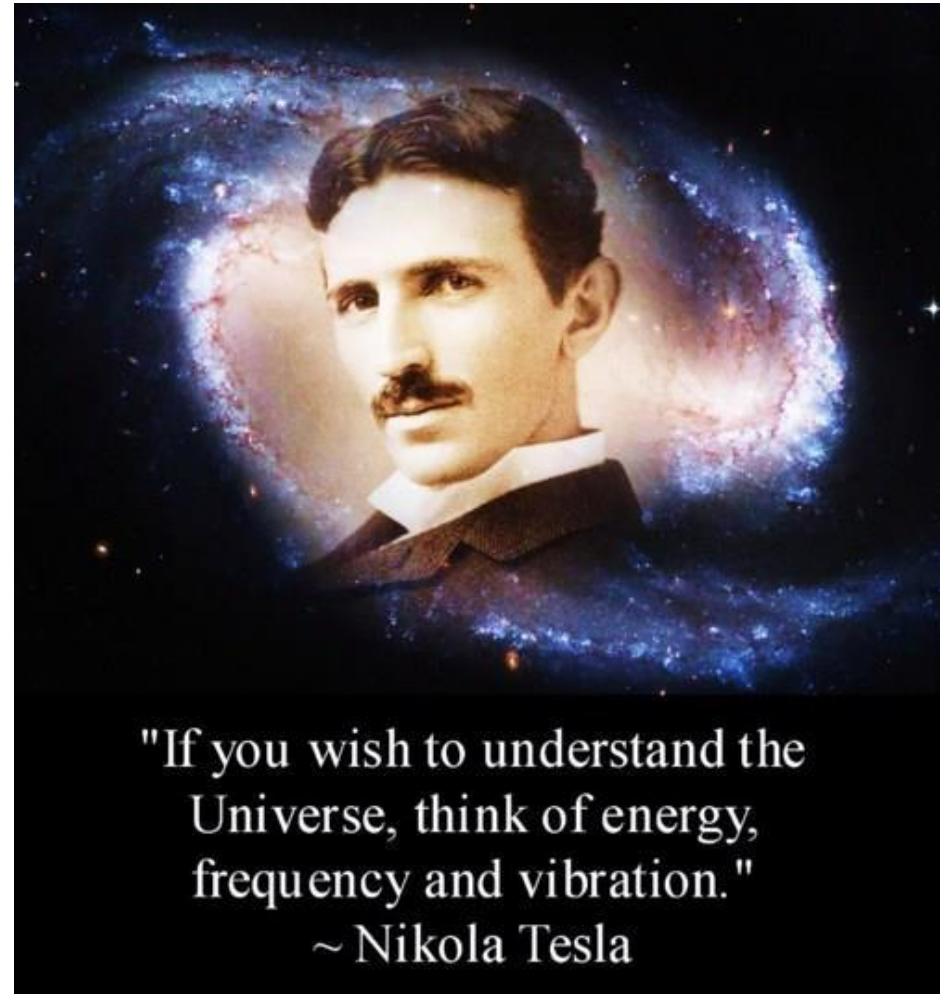

# Illustration of Sin Waves ...

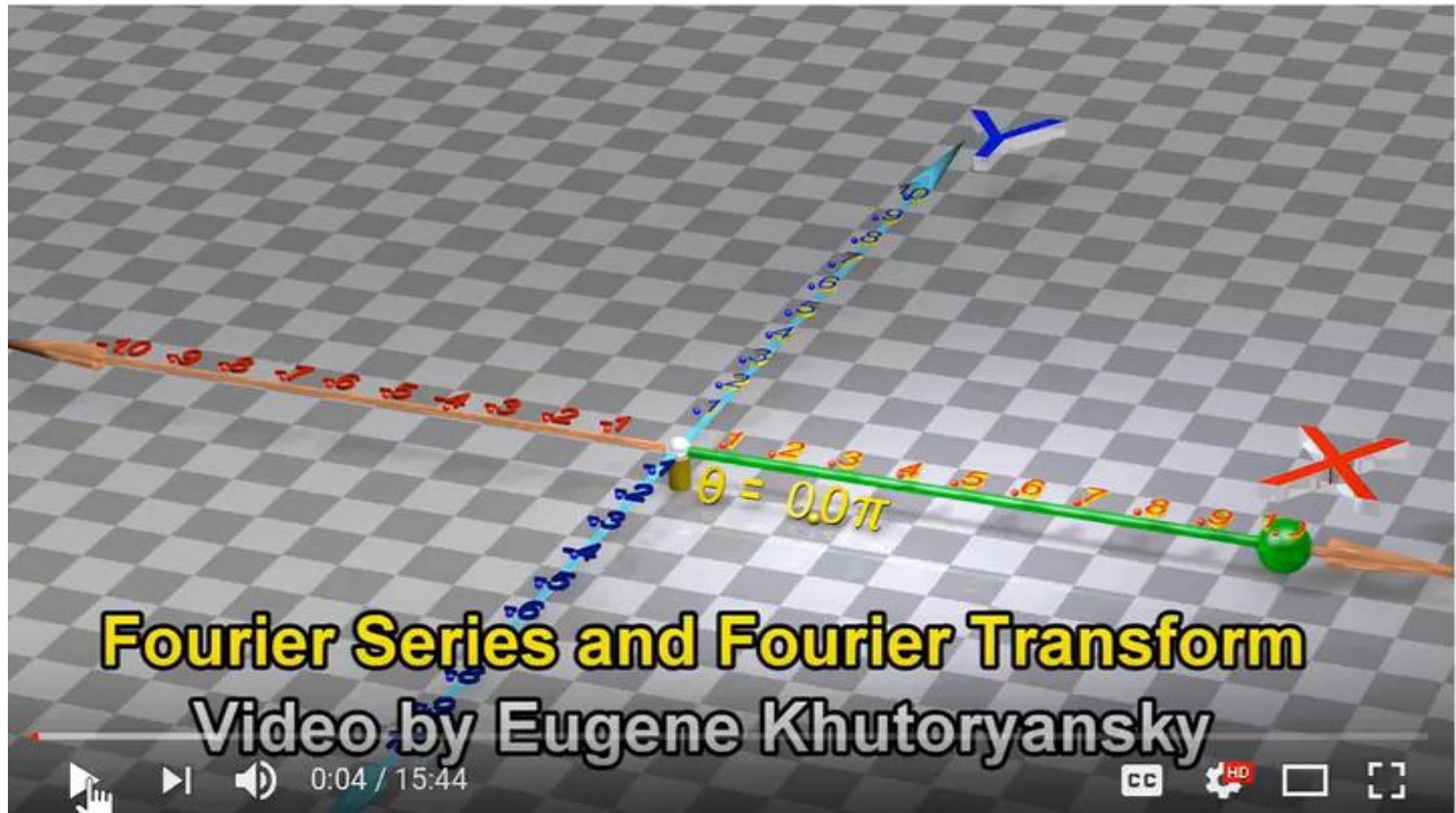

# Illustration of Sin Waves (continued)

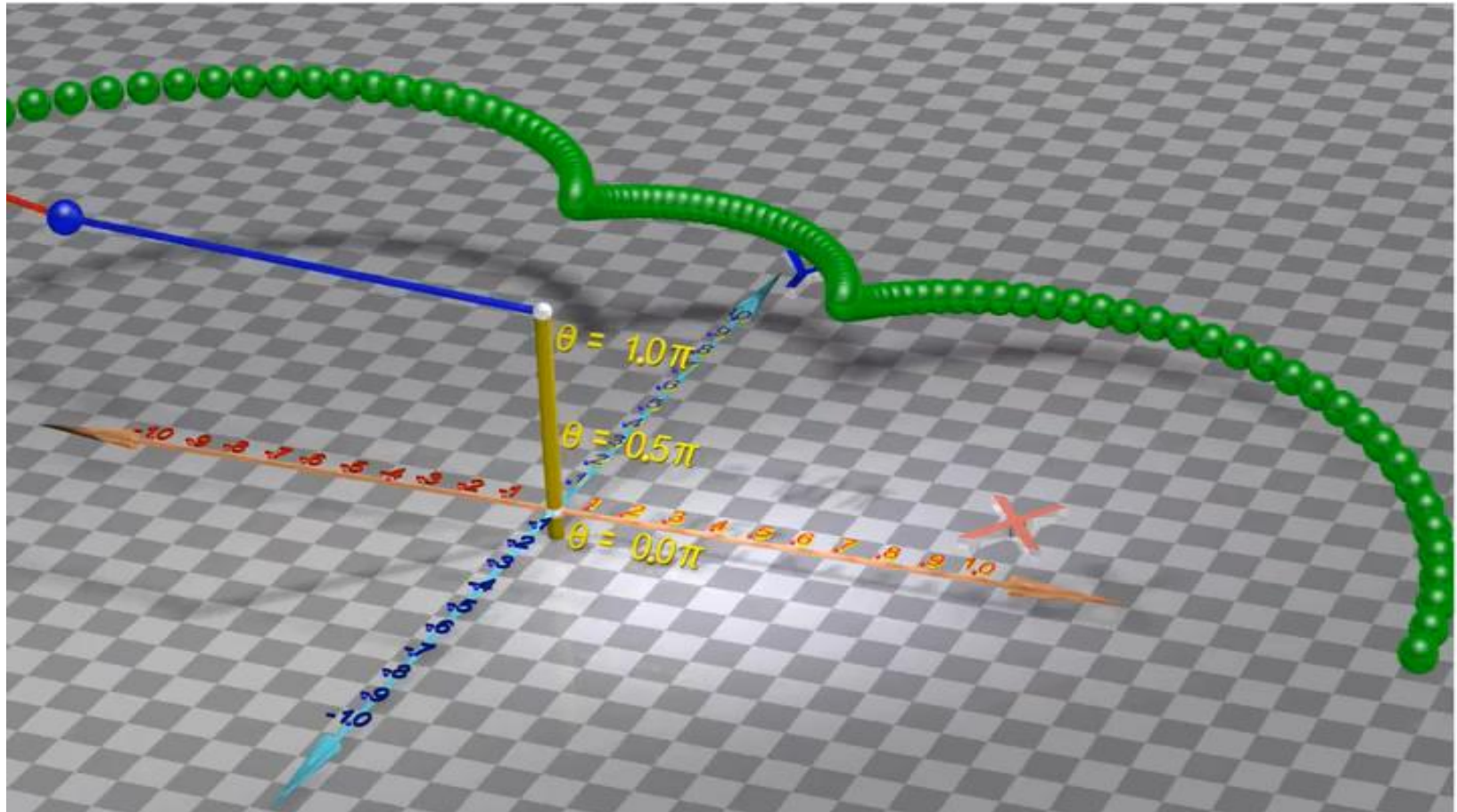

# Definition of Vibration

- ▶ Vibration refers to periodic movement of **gas, liquid or solid**. And, vibration is a phenomenon of dynamic response.

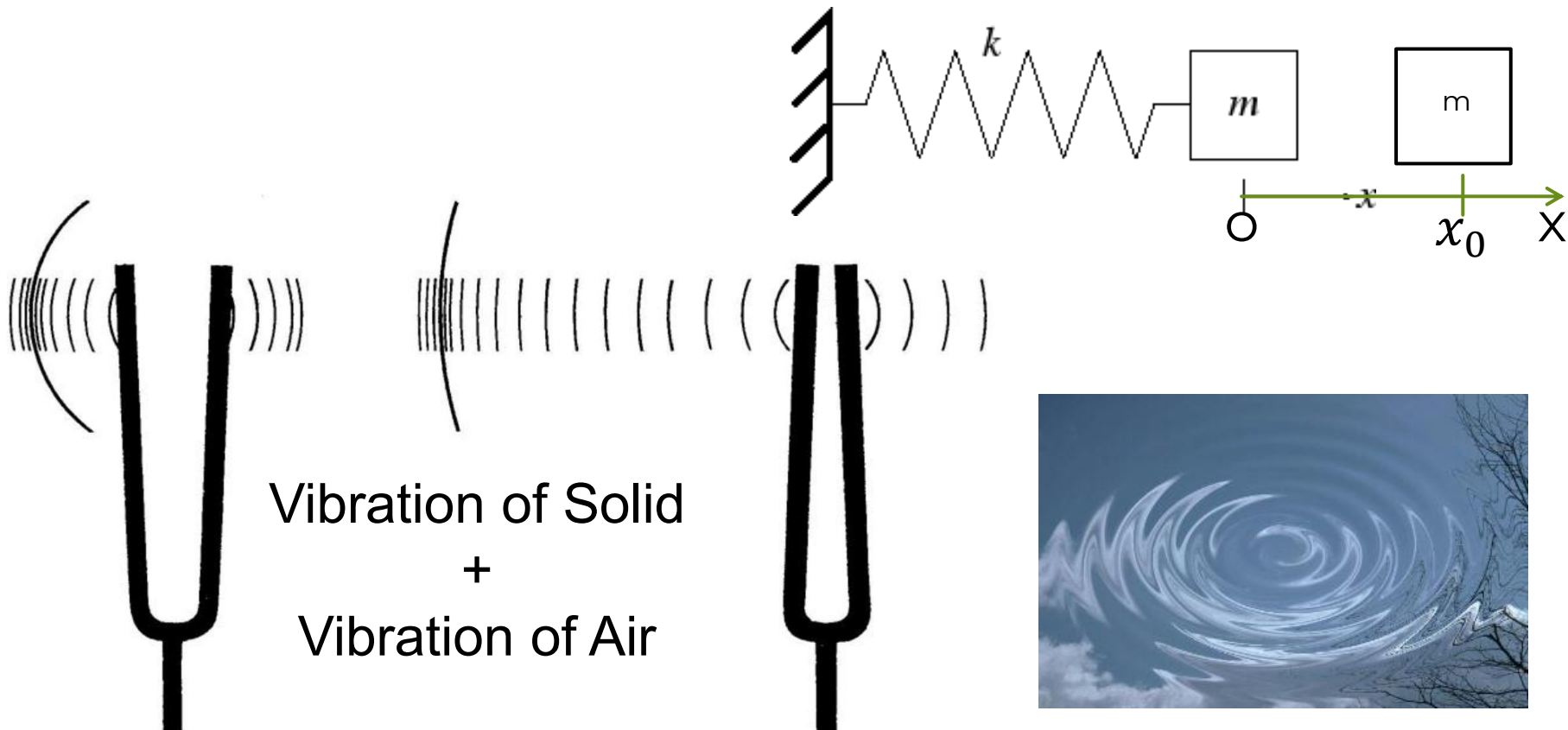

# Example of Vibration by Rigid Objects

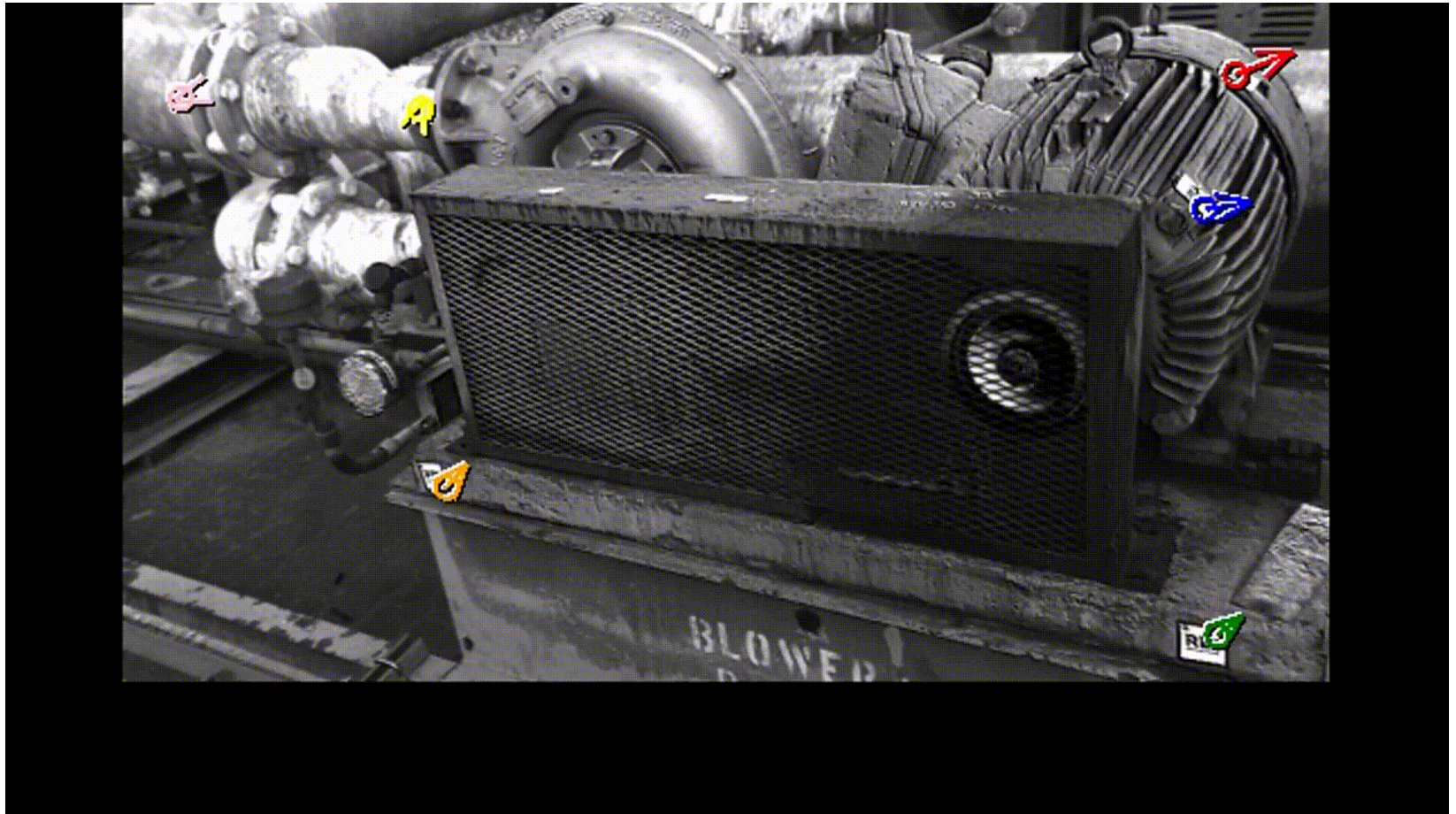

# Example of Axial Vibration of Solid

- ▶ Vibration is alternating acceleration

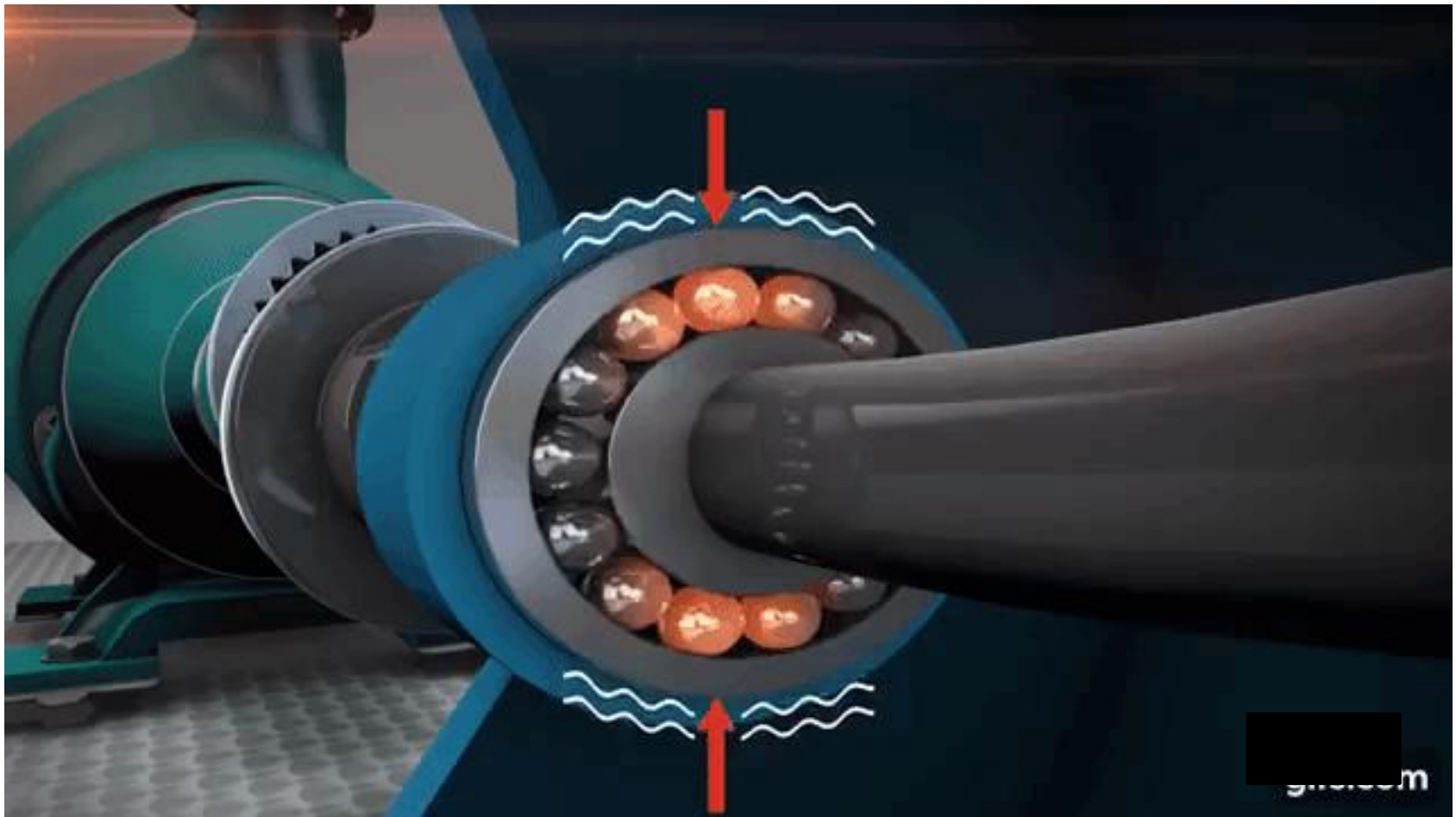

# Example of Radial Vibration of Solid

- ▶ Vibration is alternating acceleration

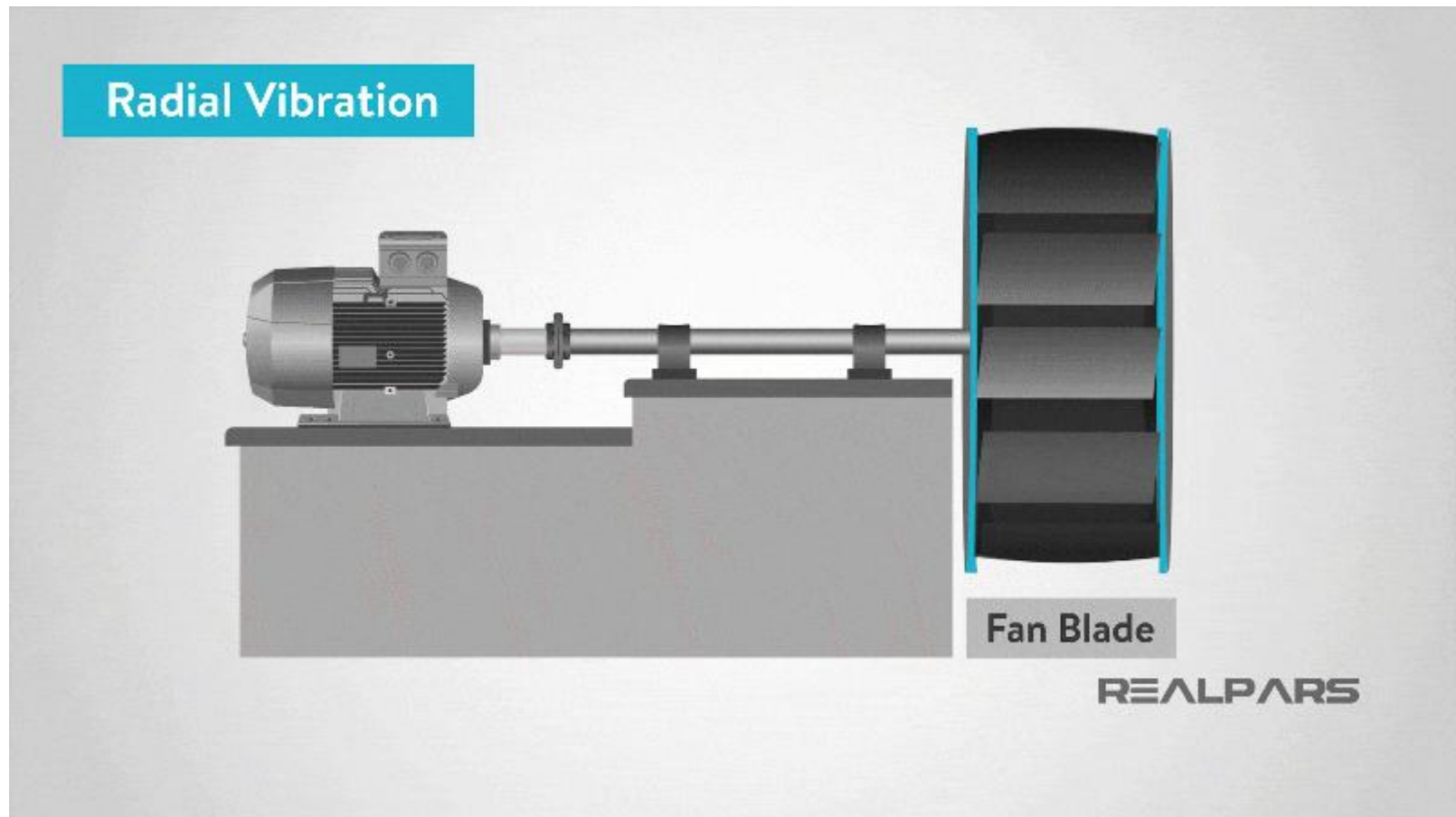

# Example of Vibration in Air

- ▶ Vibration is alternating pressure

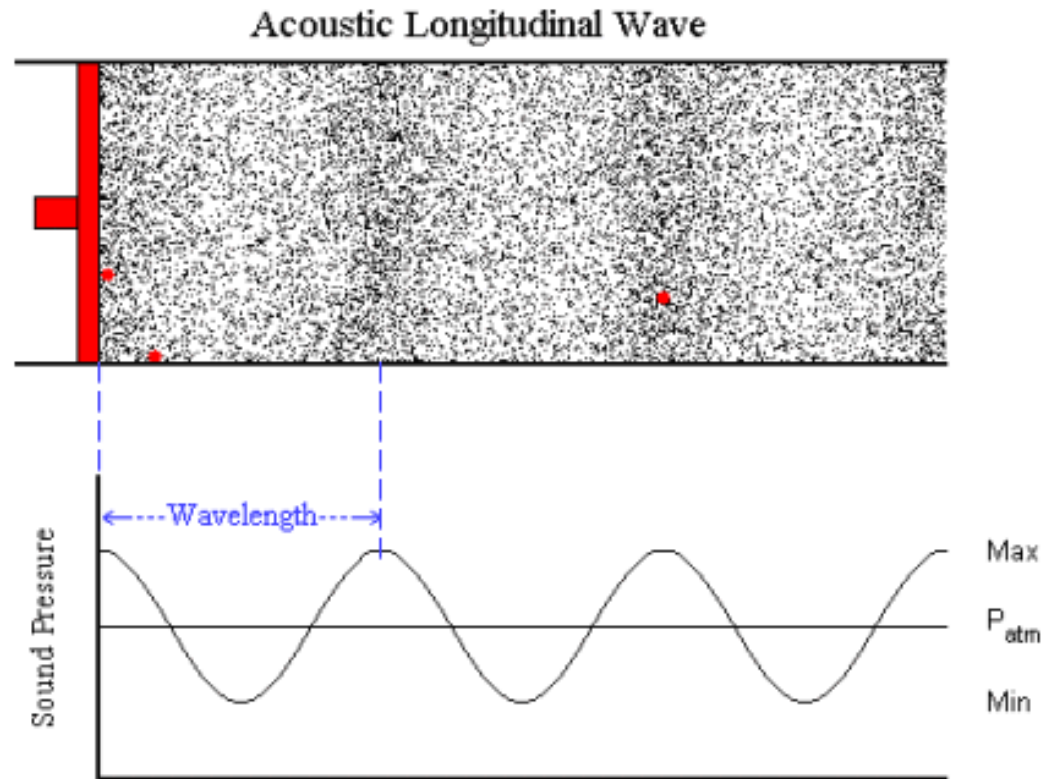

# Example of Vibration in Liquid

- ▶ Vibration is alternating displacement



# There are three types of vibrations by solids:

- ▶ a) free/natural vibrations,
- ▶ b) forced vibrations, and
- ▶ c) damped vibrations ...

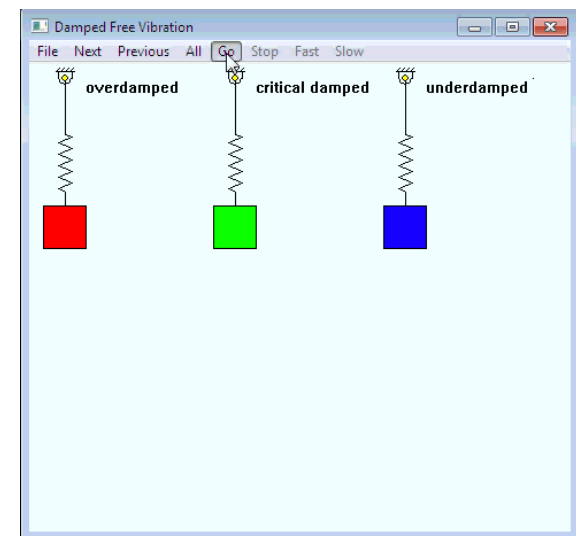
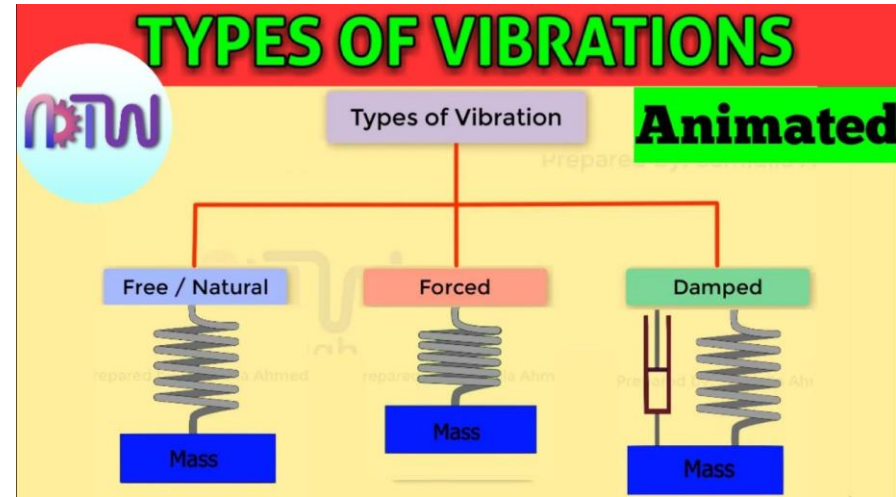

# Illustration of Dynamics of Vibration ...

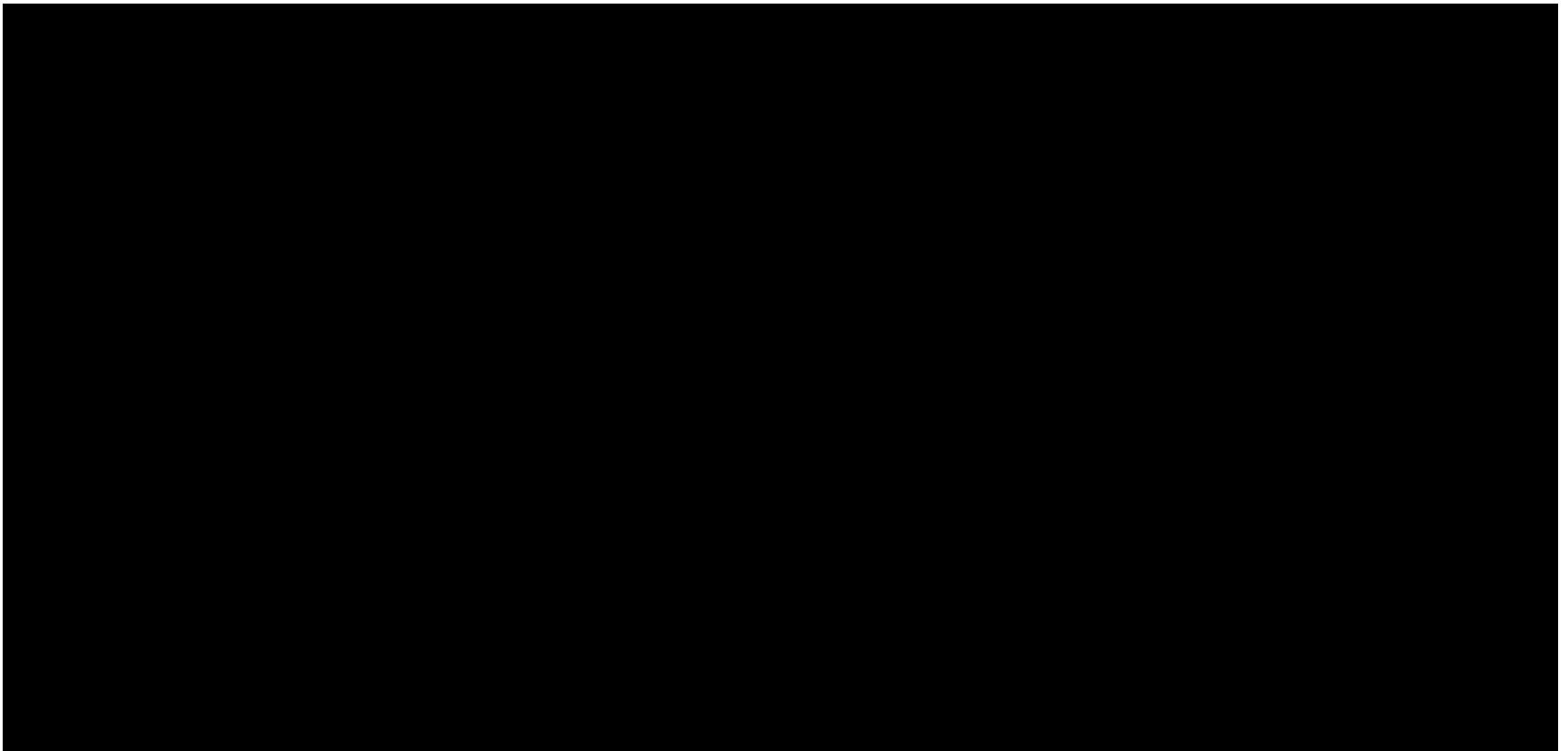

# Vibration may cause resonance ...

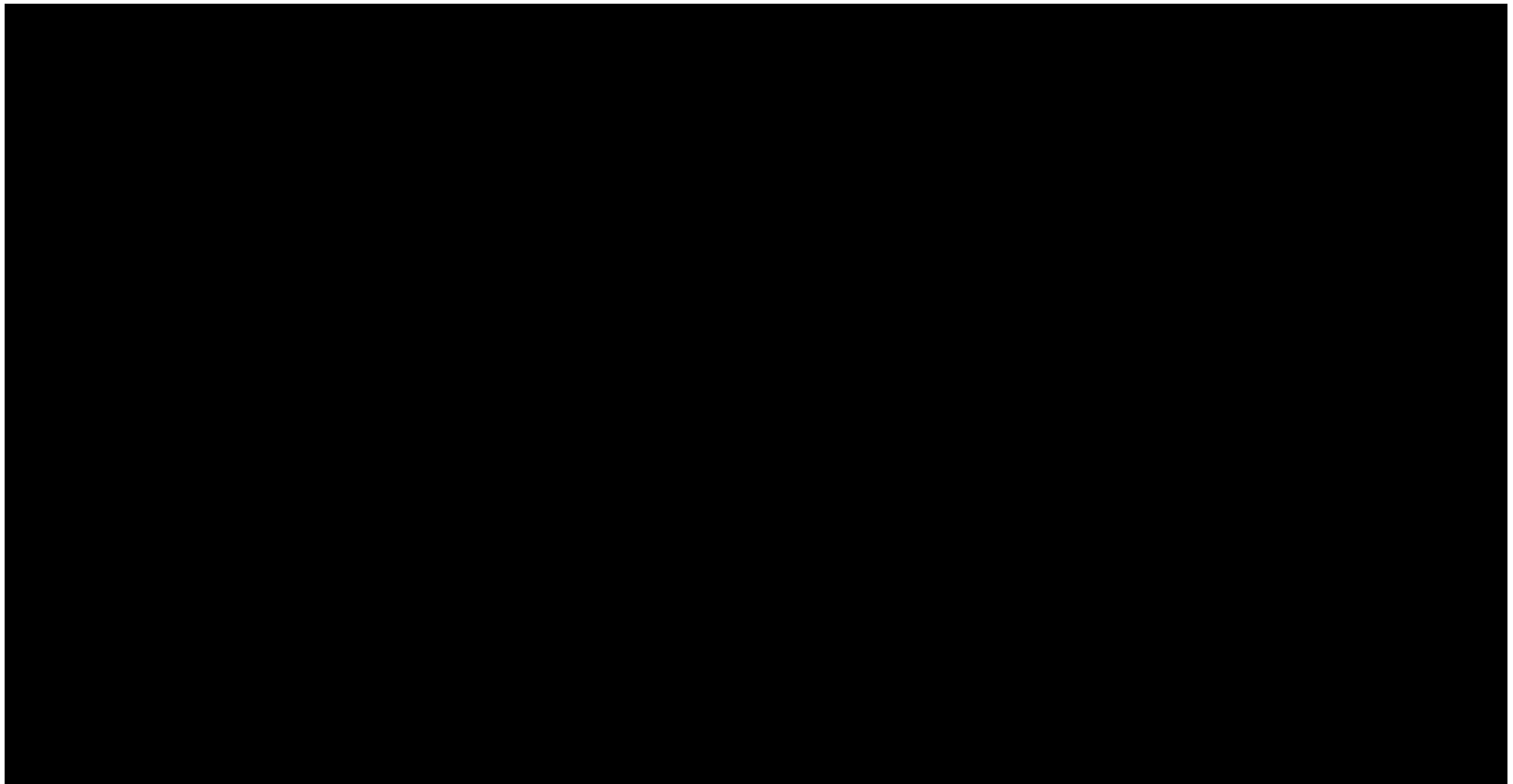

# Systems of vibration may be either SISO systems or MIMO systems ...

- ▶ SISO: Single Input, Single Output
- ▶ MIMO: Multiple Input, Multiple Output

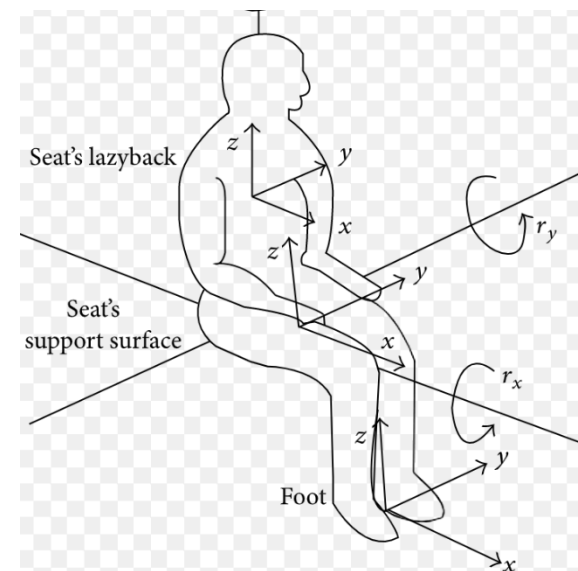
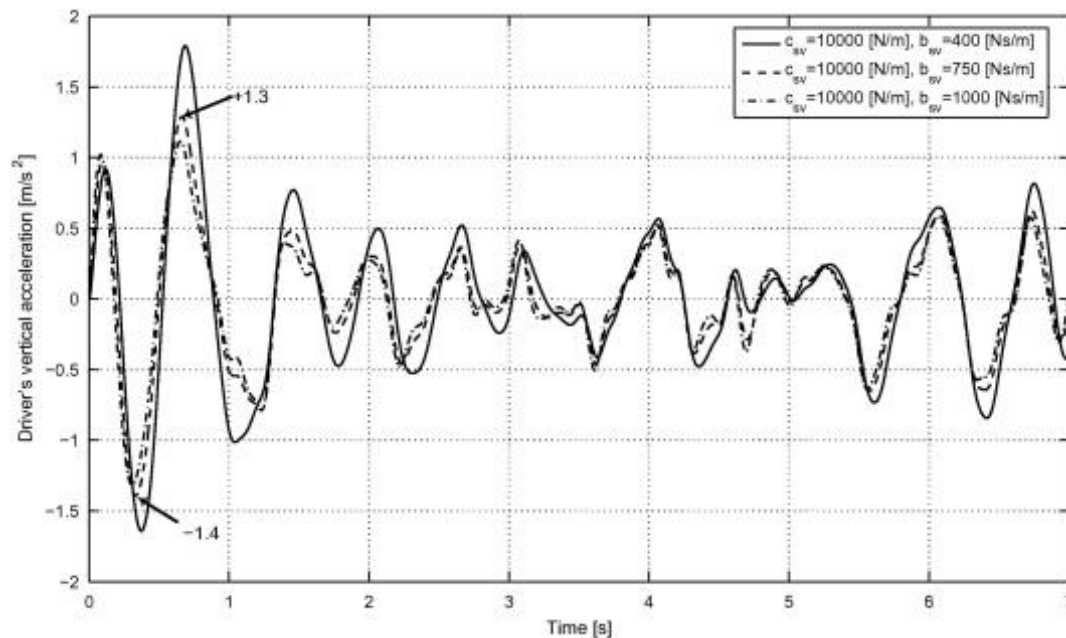

# How to analyze MIMO systems?

- ▶ Any signal is the sum of sine waves
- ▶ MIMO = Sum of SISOs

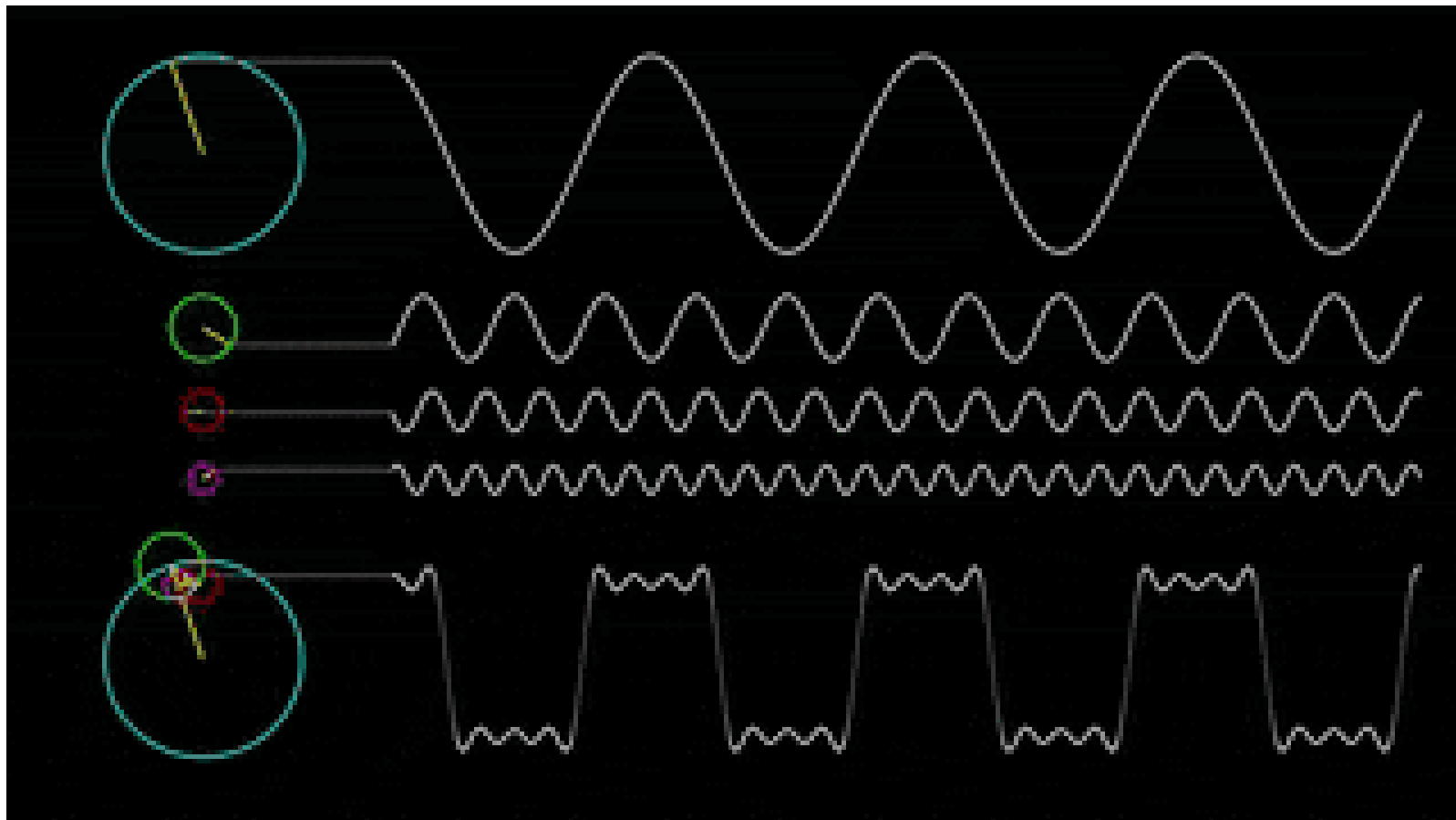

# Quantities of Ideal Vibration Signal

✓ ▶ Angular Speed

▶ Period or Wavelength

▶ Frequency

✓ ▶ Amplitude (Peak)

▶ Average

▶ Root Mean Square

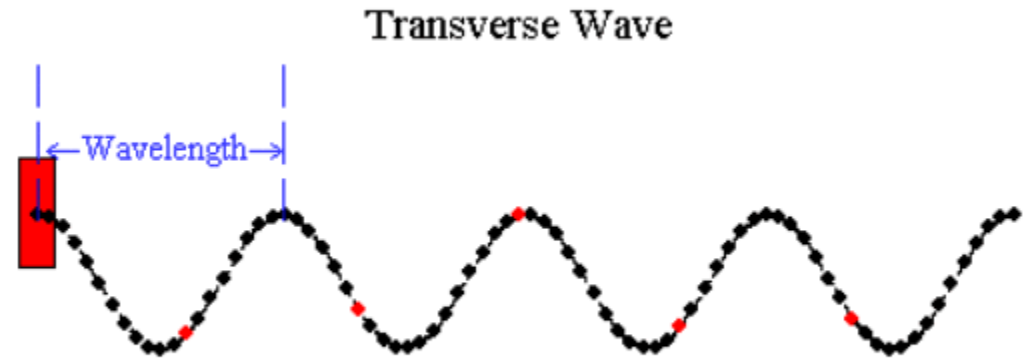

$$y = A \sin(\omega t + \varphi_0)$$

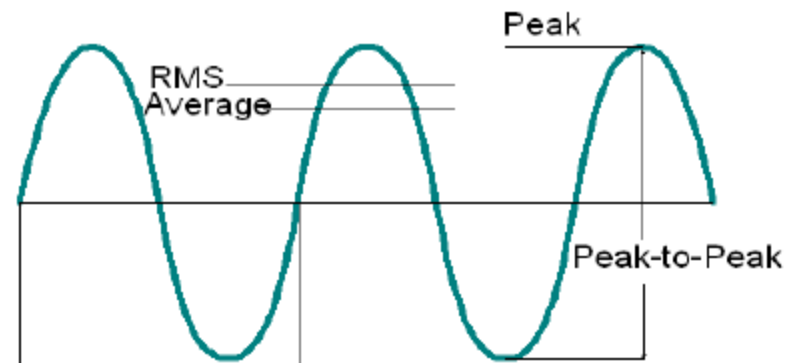

# Angular Speed

$$y = A \sin(\omega t + \varphi_0)$$

$$\omega = 2\pi f$$

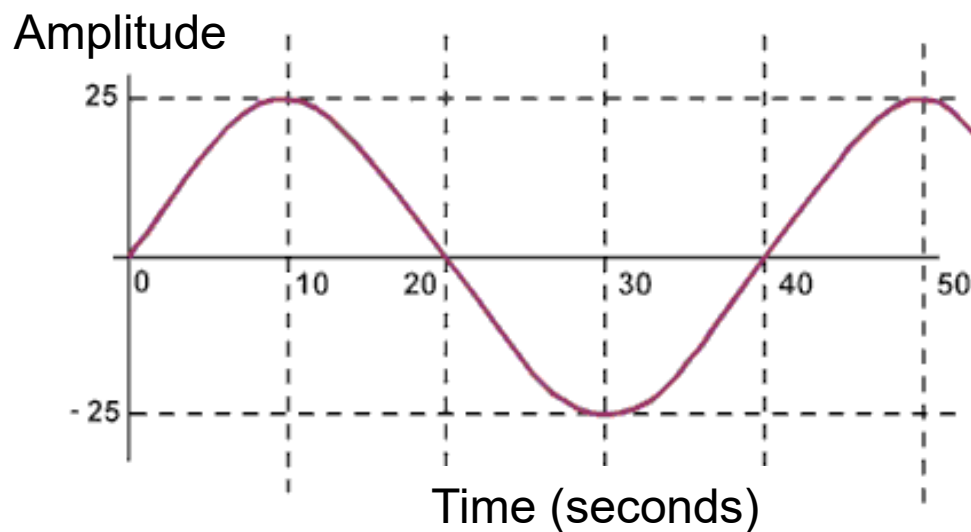

# Period or Wavelength

$$\omega T = 2\pi \quad \rightarrow \quad T = \frac{2\pi}{\omega}$$

$$\omega = 2\pi f$$

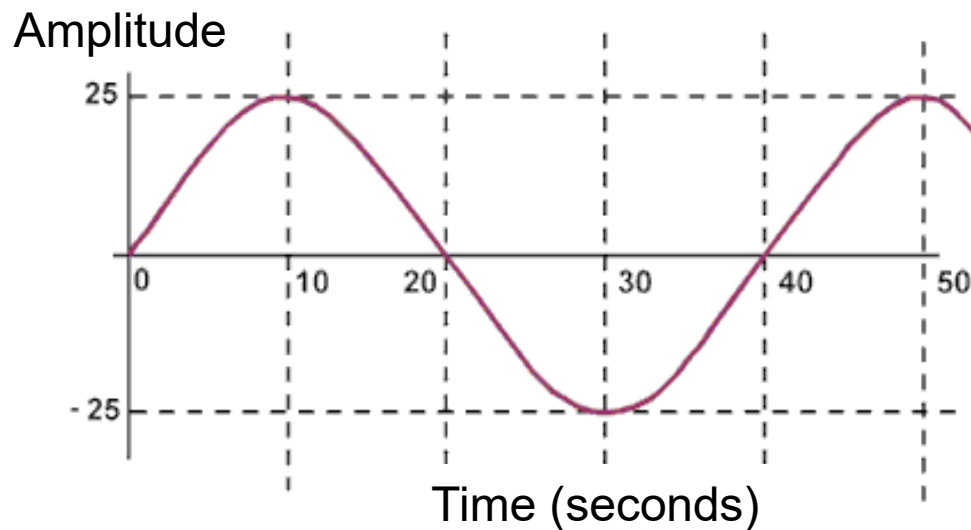

# Frequency

$$f = \frac{1}{T} \qquad \qquad \qquad f = \frac{\omega}{2\pi}$$

$$\omega = 2\pi f$$

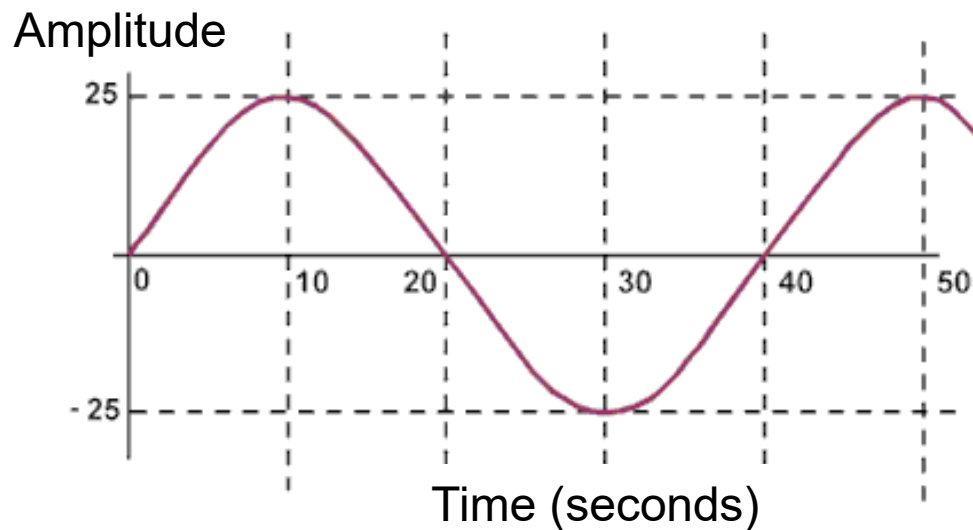

# Amplitude

$$y = A \sin(\omega t + \varphi_0)$$

$$\omega = 2\pi f$$

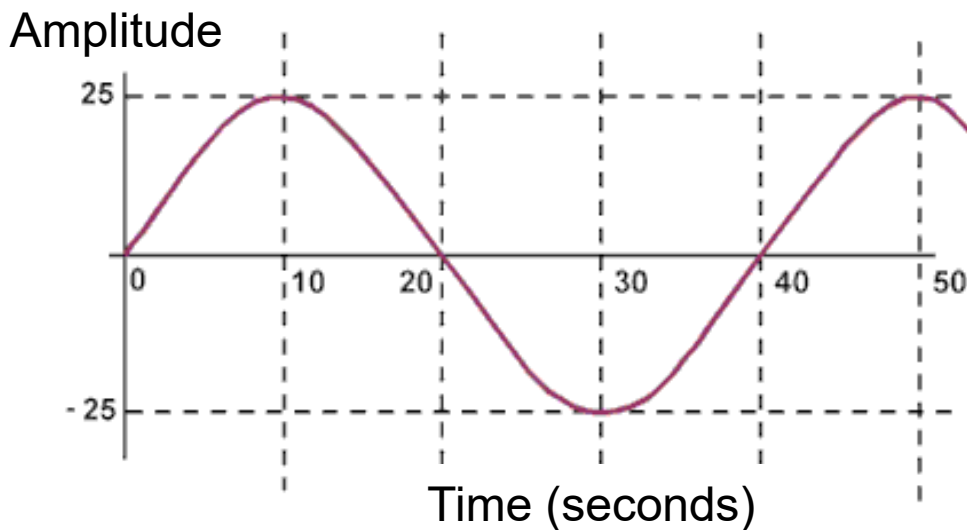

# Outline

- ▶ Understanding of Vibration
- ▶ Computation of Vibration
- ▶ Measurement of Vibration

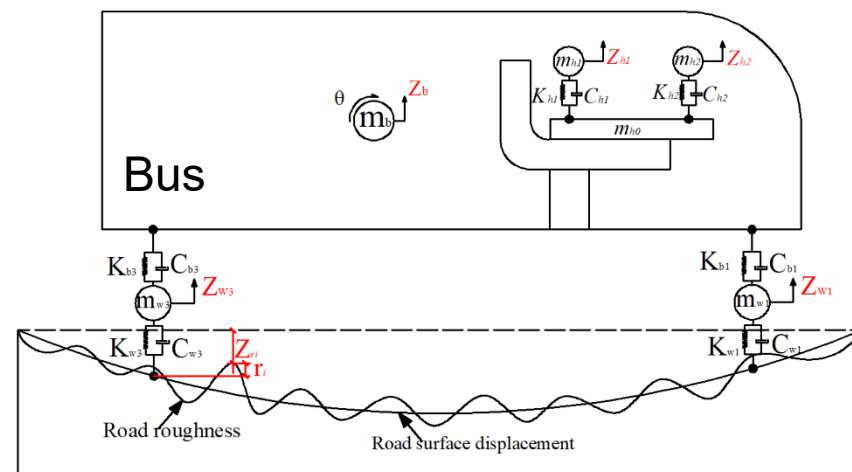

# There Are Two Scenarios of Doing Computation

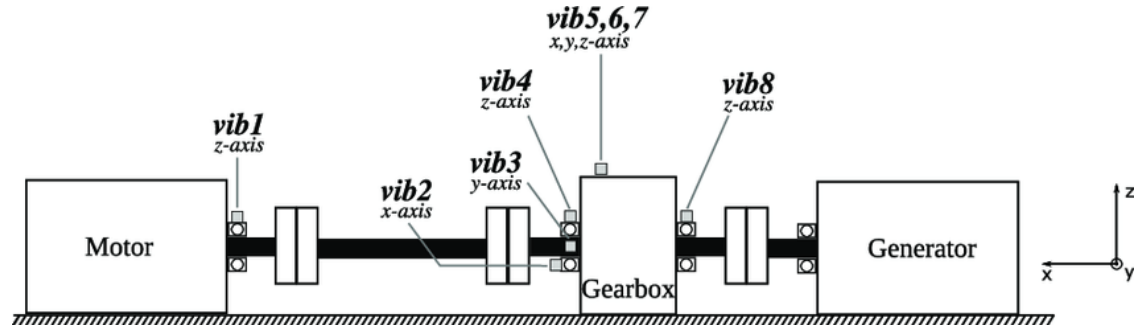

- Scenario 1: We know the individual sine functions of all the vibration sources. Then, we can compute the combined vibration signal.

$$f(t) = \sum_{i=0}^n A_i \sin(\omega_i t + \varphi_i)$$

- Scenario 2: We know a vibration signal. Then, we could compute its individual sine functions. This is because vibration is a combination of a finite number of sources.

(Fourier Transform)

# Forward Fourier Transform

$$F(j\omega) = \int_{-\infty}^{+\infty} f(t)e^{-j\omega t} dt \quad \Rightarrow \quad F(j\omega) = \int_{-\infty}^{+\infty} \frac{f(t)}{\cos(\omega t) + j \sin(\omega t)} dt$$

$$\omega = 2\pi f$$

$$s = \sigma + j\omega$$

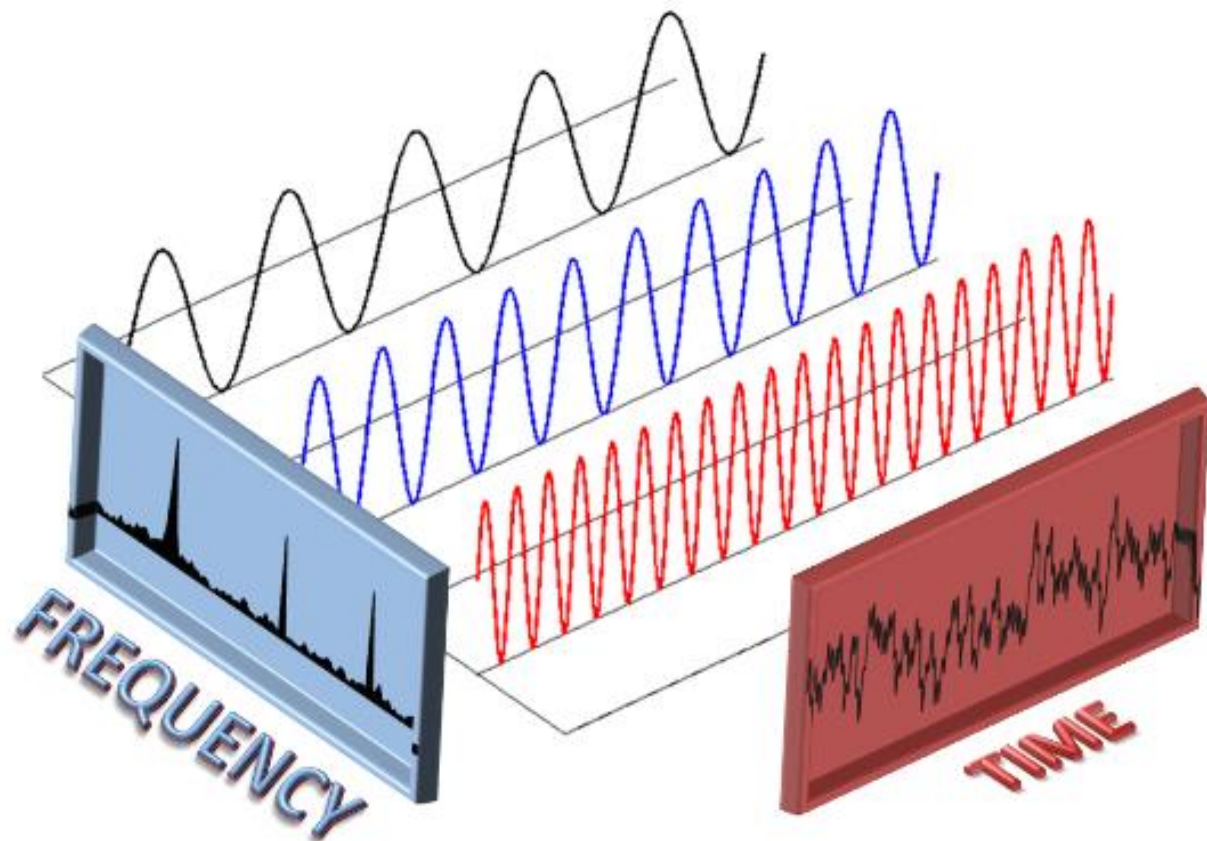

# Example of Doing Forward Fourier Transform

Computing Vibration Signal's Quantities

$$F(j\omega) = \int_{-\infty}^{+\infty} \frac{f(t)}{\cos(\omega t) + j \sin(\omega t)} dt$$

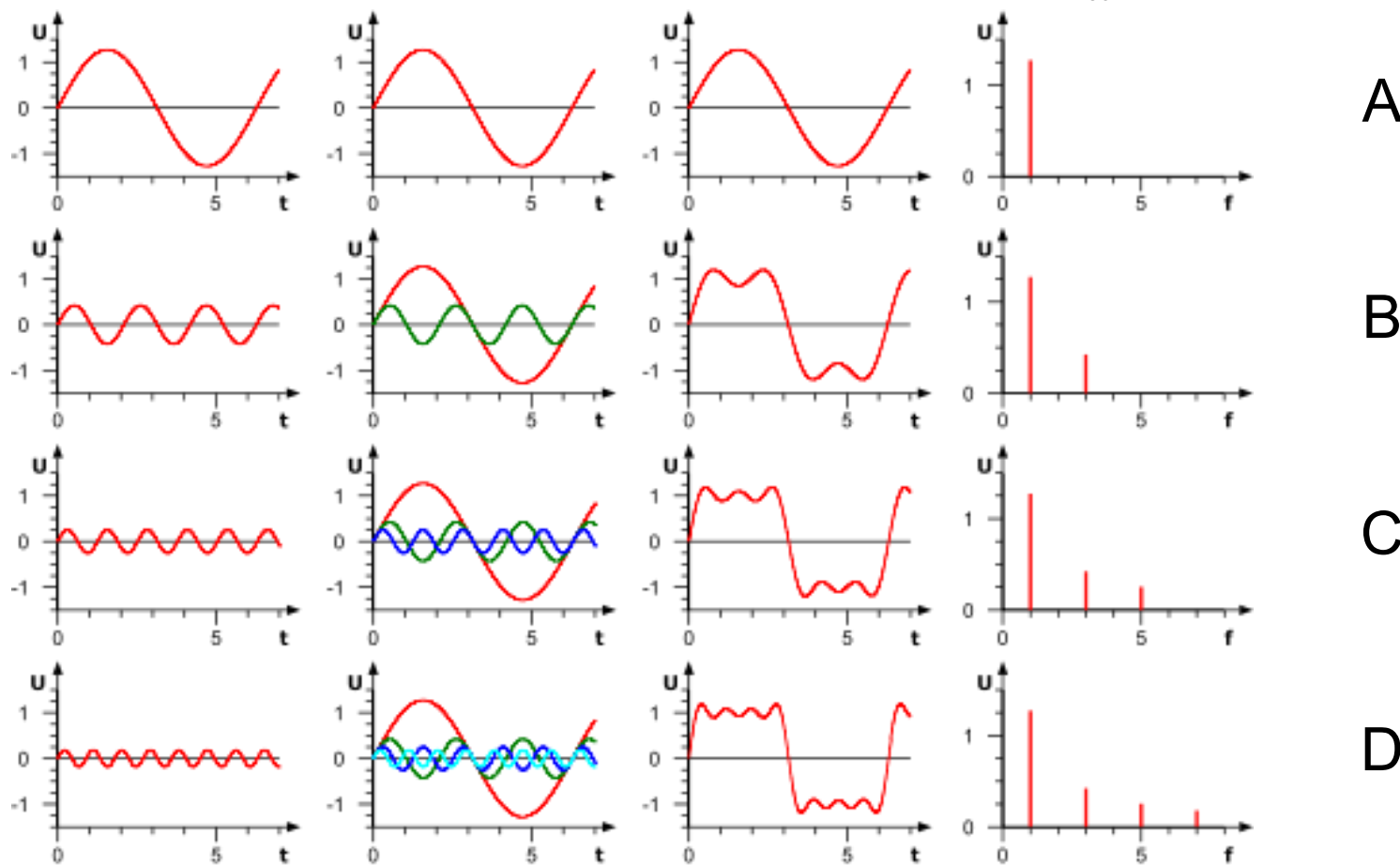

# Inverse Fourier Transform

$$f(t) = \frac{1}{2\pi} \int_{-\infty}^{\infty} F(j\omega) e^{j\omega t} d\omega$$

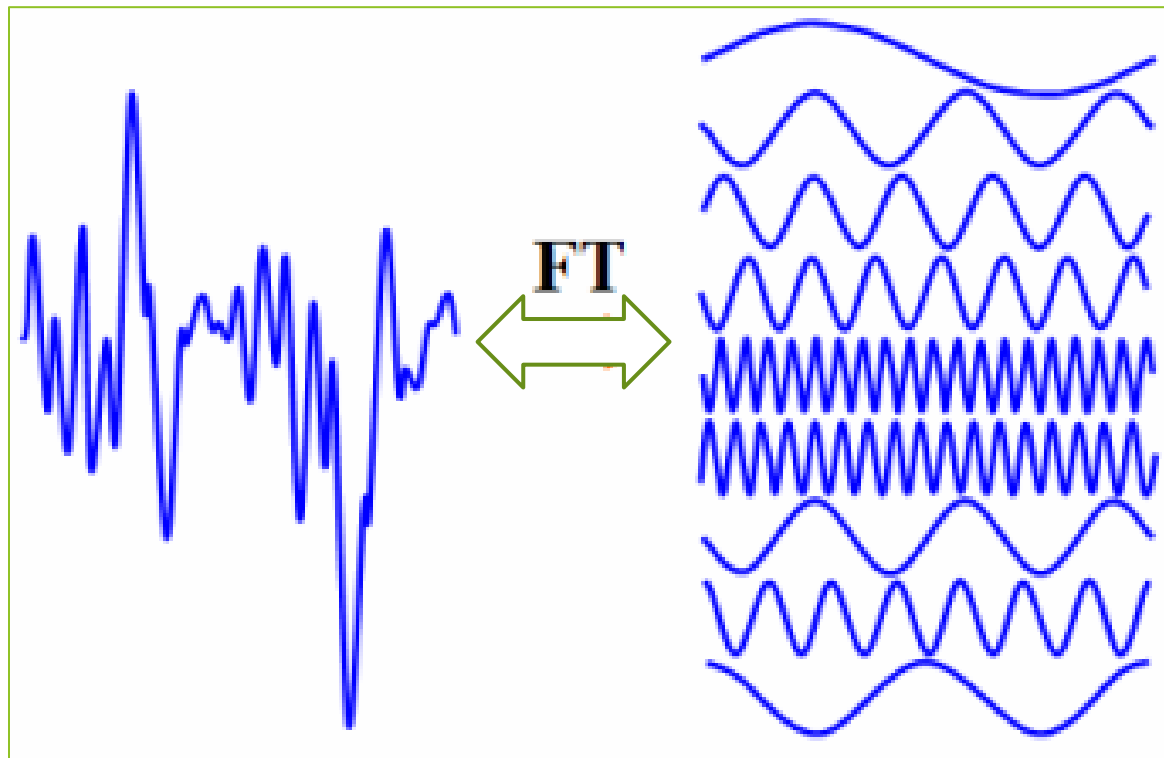

$$f(t) = \sum_{i=0}^n A_i \sin(\omega_i t + \varphi_i)$$

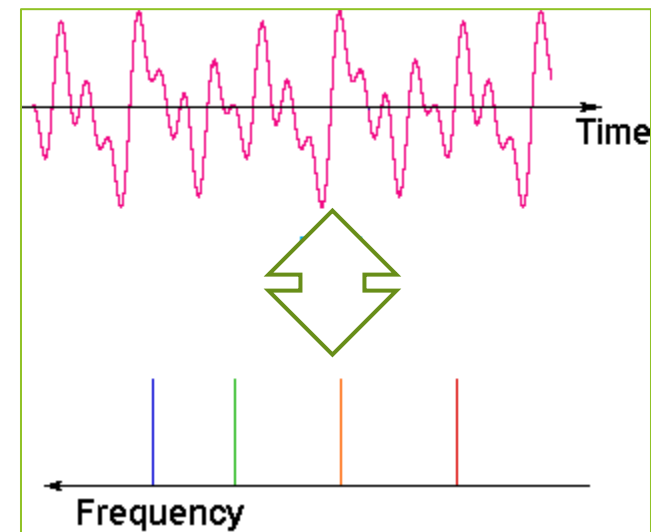

# Exercise

- ▶ What is the equation which describes the following output from a measurement of vibration due to multiple sources?

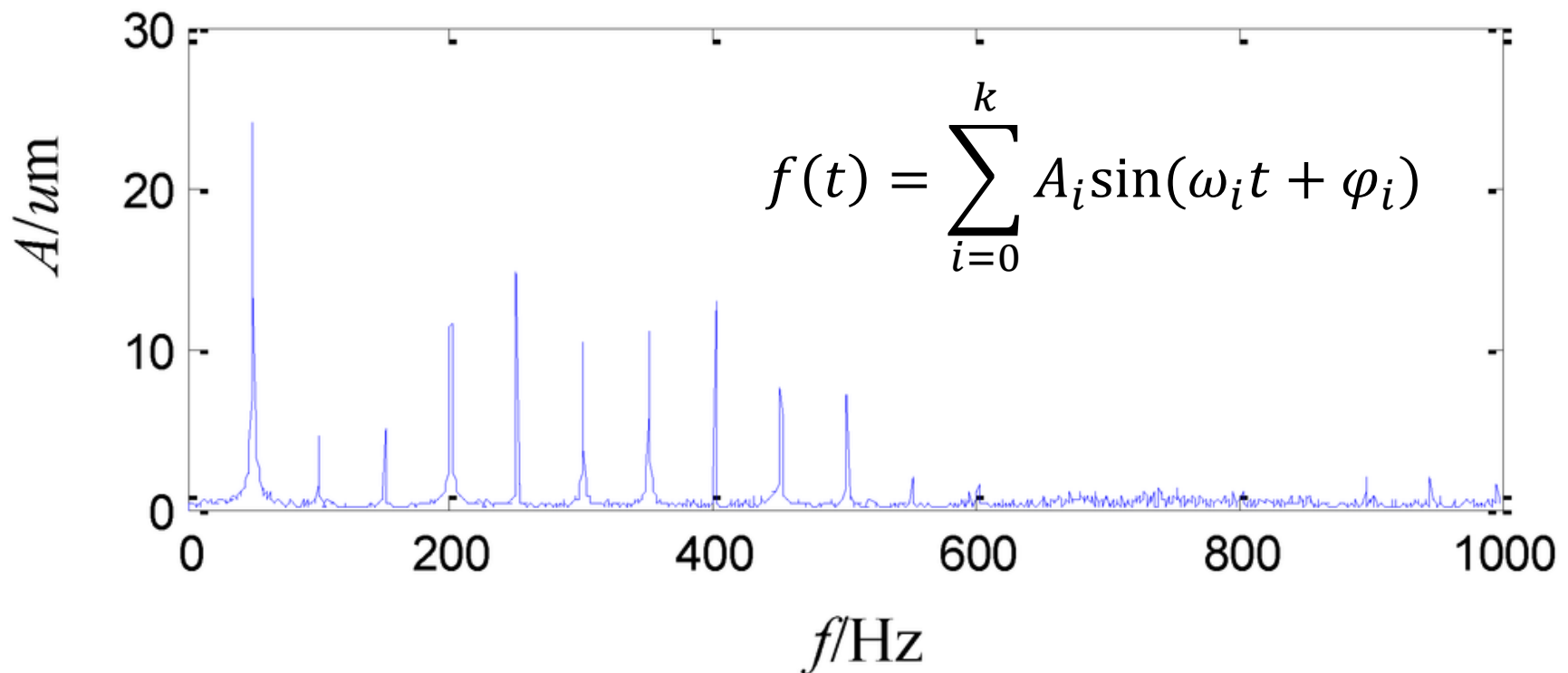

# Another Way to Do Fourier Transform (1)

$$g(t) = g_0 + \sum_{i=0}^n A_i \sin(2\pi f_i t)$$

$$t_k = \frac{\theta_k}{2\pi f_j}, k = 0, 1, 2, \dots, 359$$

$$C_x(f_j) = \text{Center}\{g(t_k) \cos(\theta_k)\}$$

Vibration = Wave of Pressure

Vibration = Wave of Acceleration

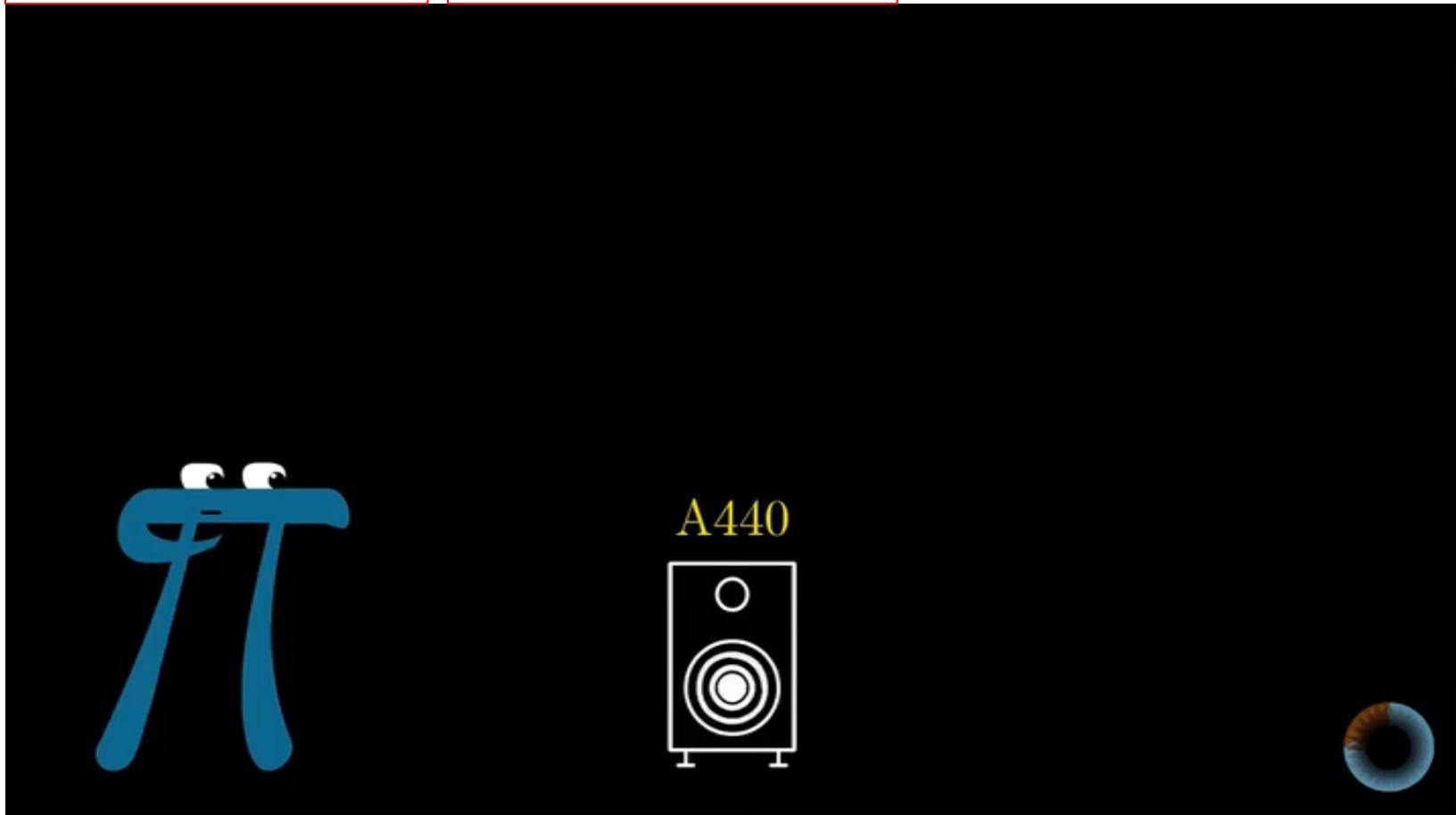

# Another Way to Do Fourier Transform (2)

$$g(t) = g_0 + \sum_{i=0}^n A_i \sin(2\pi f_i t)$$

$$t_k = \frac{\theta_k}{2\pi f_j}, k = 0, 1, 2, \dots, 359$$

$$C_x(f_j) = \text{Center}\{g(t_k) \cos(\theta_k)\}$$

Vibration = Wave of Pressure

Vibration = Wave of Acceleration

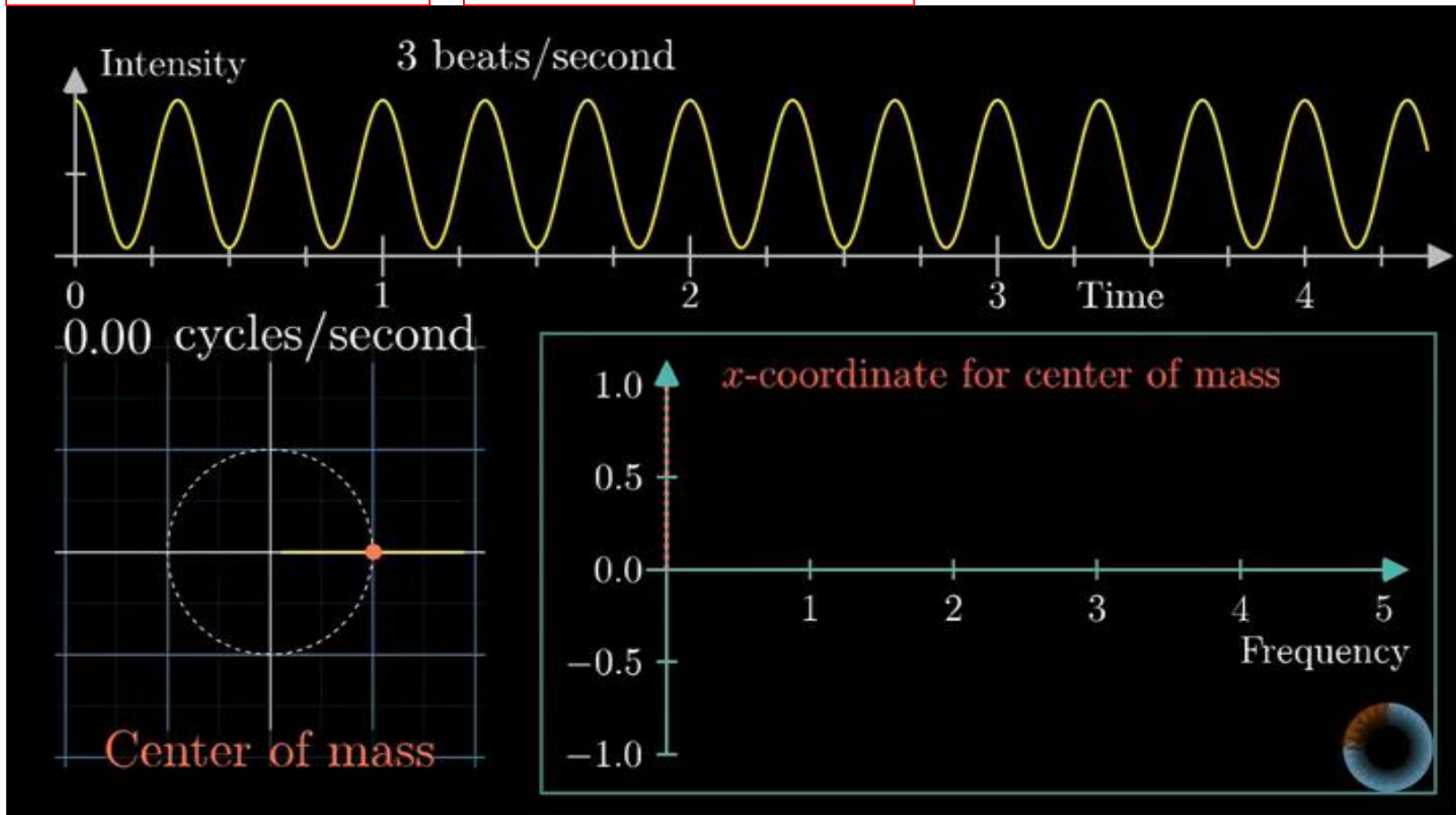

# Outline

- ▶ Understanding of Vibration
- ▶ Computation of Vibration
- ▶ Measurement of Vibration

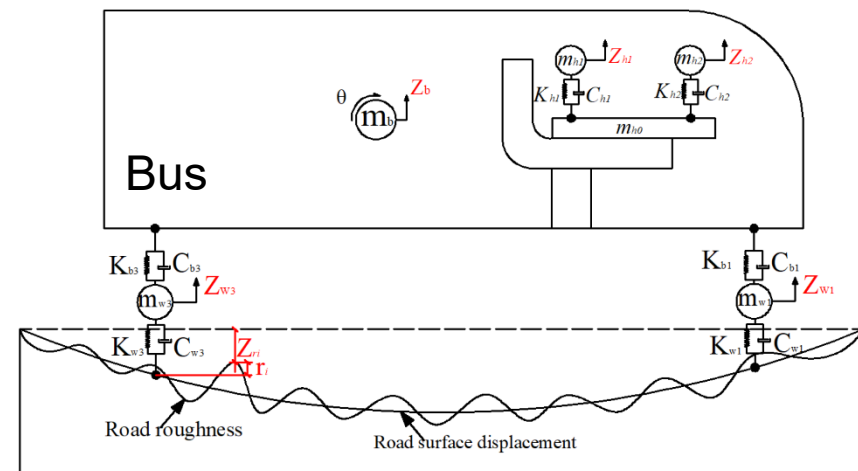

# Applications in Motion Machines

## Ultrasonic Linear and Rotary Motion

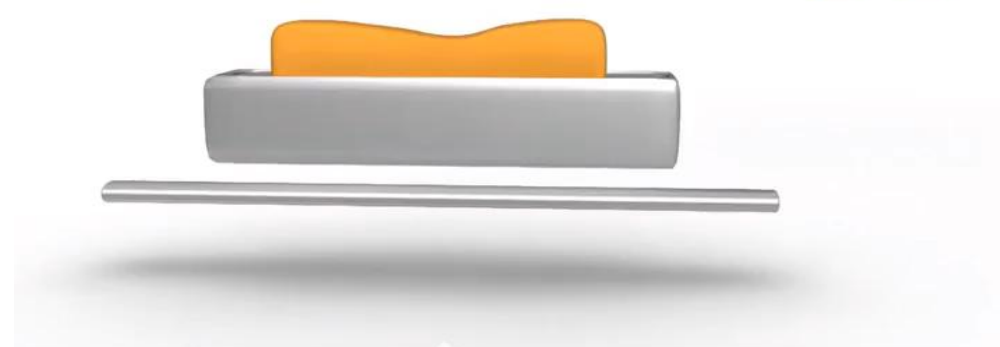

PI ultrasonic piezomotors are based on minute oscillations at inaudible frequencies (100's of kHz) generated by a piezo actuator. Each cycle transfers nanoscopic motion to a linear or rotary ceramic surface bonded to a linear runner or rotary platform.

### High-Speed, Miniature Rotary Stage

PILINE® ULTRASONIC PIEZOMOTOR TECHNOLOGY



# Applications in Dynamic Condition Monitoring of Rotary Machines



# Applications in Dynamic Condition Monitoring

- Axial misalignment in transmission
- Radial uneven distribution of masses

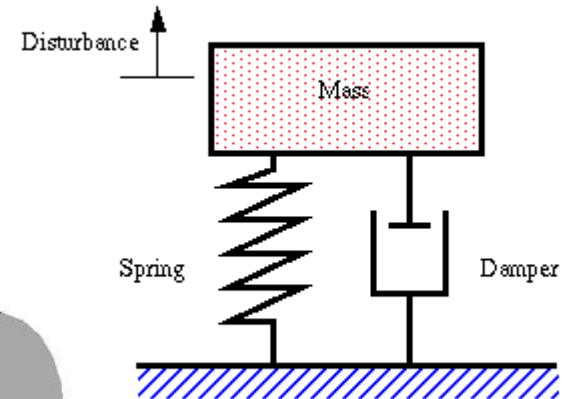
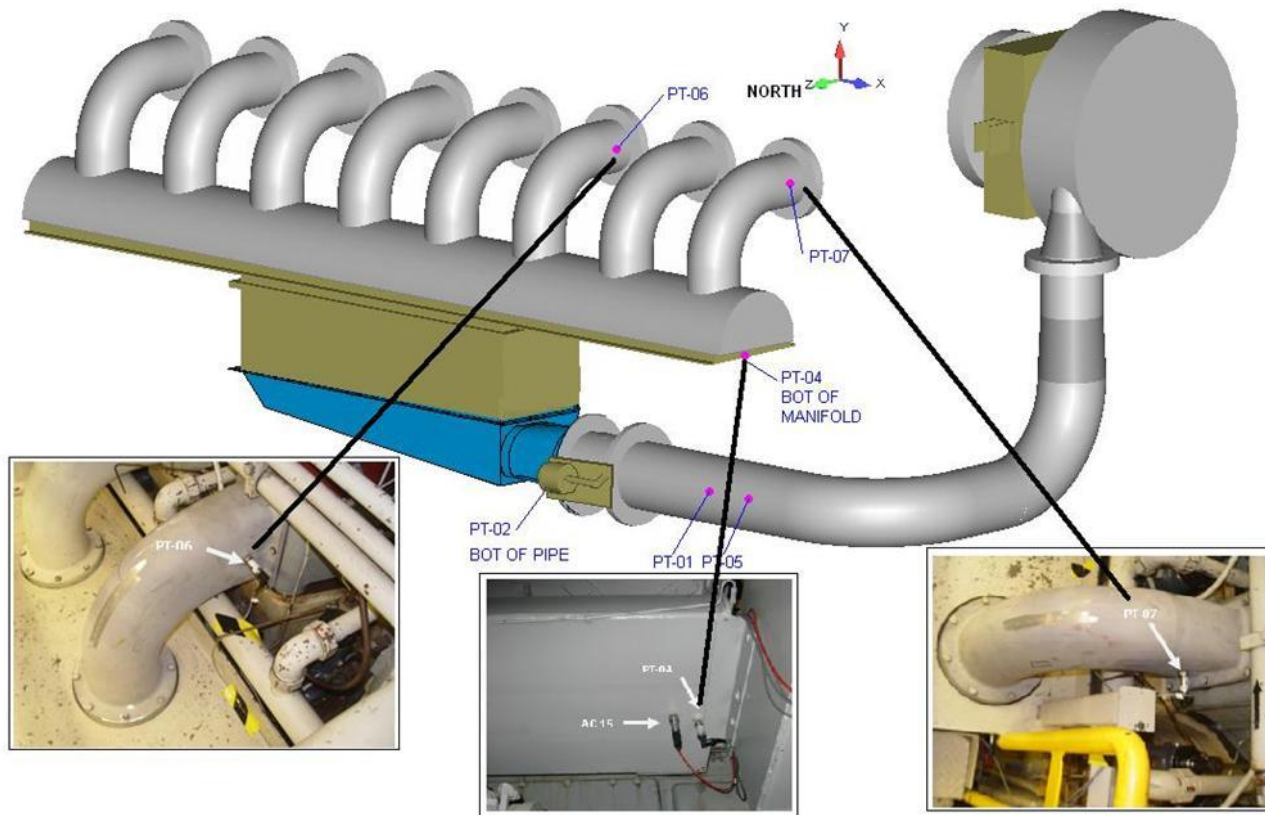

# Principles of Measurement

- ▶ **Principle 1:** Vibration of rigid body could be converted into periodic signal of **DC voltage**, which could be automatically measured.
  - ▶ **Principle 2:** Vibration of rigid body could be converted into periodic change in **magnitude of AC voltage**, which could then be converted into periodic signal of DC voltage. DC voltage could be automatically measured.
- Transformer = Sending Coil + Receiving Coil
- ▶ **Principle 3:** Vibration of rigid body could be converted into periodic change in **resistance**, which could then be converted into periodic signal of DC voltage. DC voltage could be automatically measured.

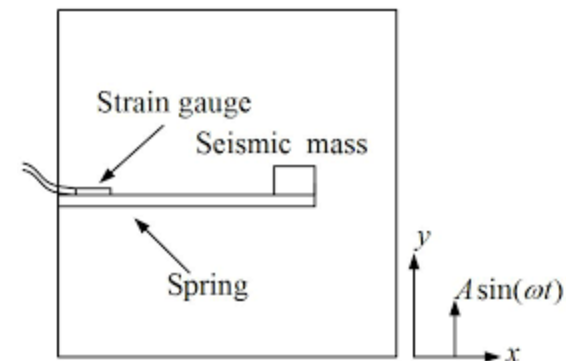
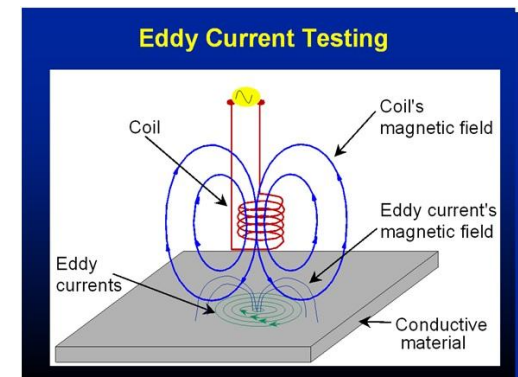
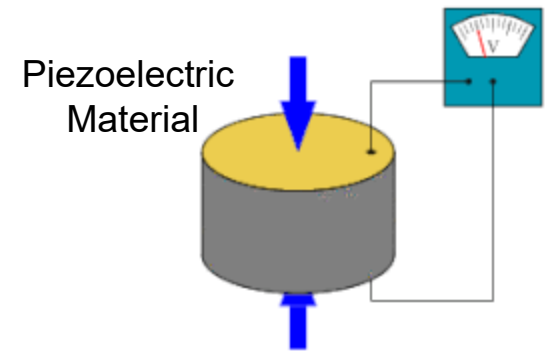

# How to apply principle 1 to design digital measurement and sensing systems for vibration?

- ▶ Vibration is converted to periodic signal of DC voltage which is measured by digital voltmeter (e.g. microcontrollers).

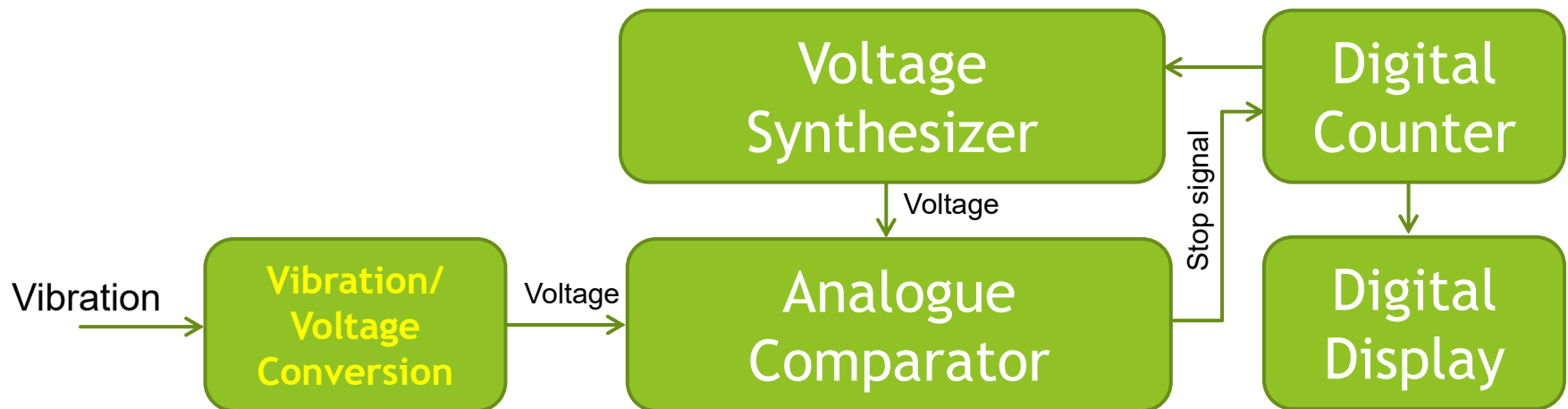

All microcontrollers are programmable digital sensors of voltage!

# How to convert vibration into periodic signal of DC voltage?

$$v_{out}(t) = A \sin(\omega_v t + \phi_0)$$

- ▶ To use Piezoelectric Effect
  - ▶ Applied mechanical vibrations produce voltages.
  - ▶ Applied voltages produce mechanical vibrations.

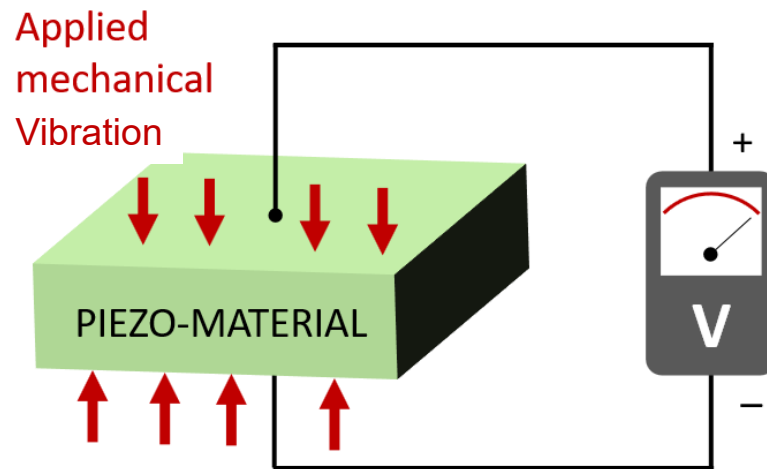

Sensing of Vibration

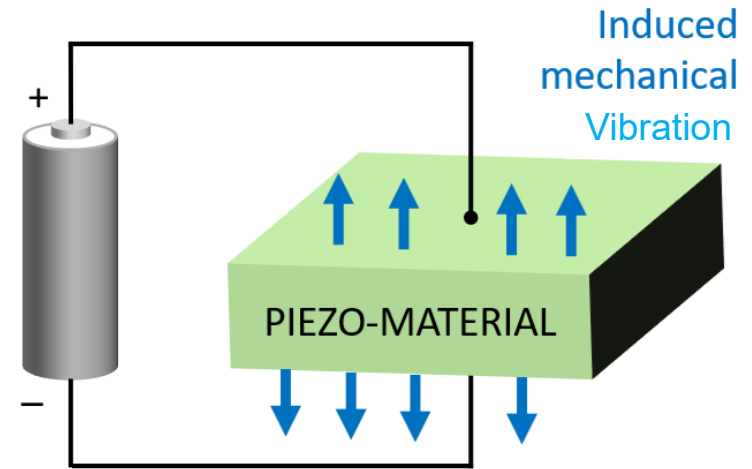

Synthesis of Vibration

# More illustration ...

Periodic voltage produced by vibration

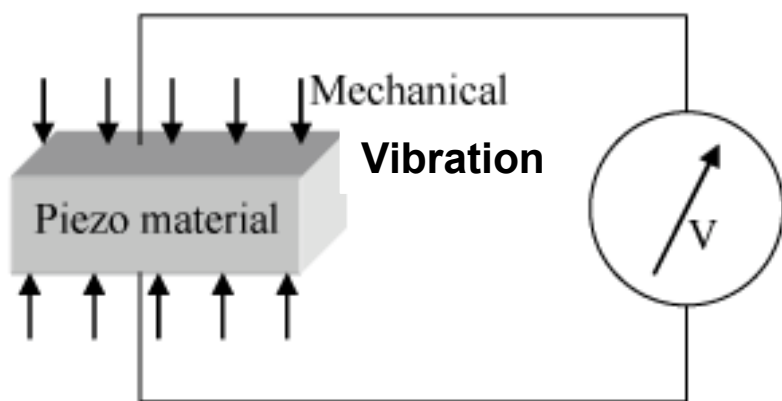

$$V(t) = V_0 + \Delta V(t)$$

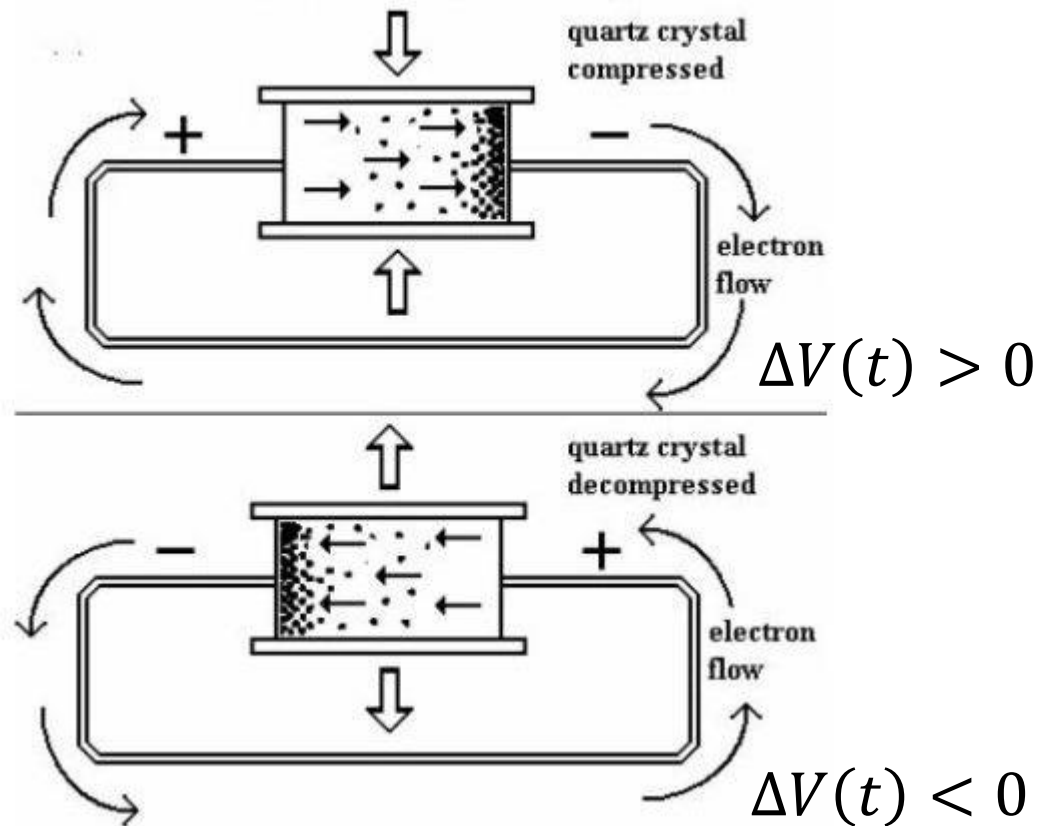

# Example of Implementation

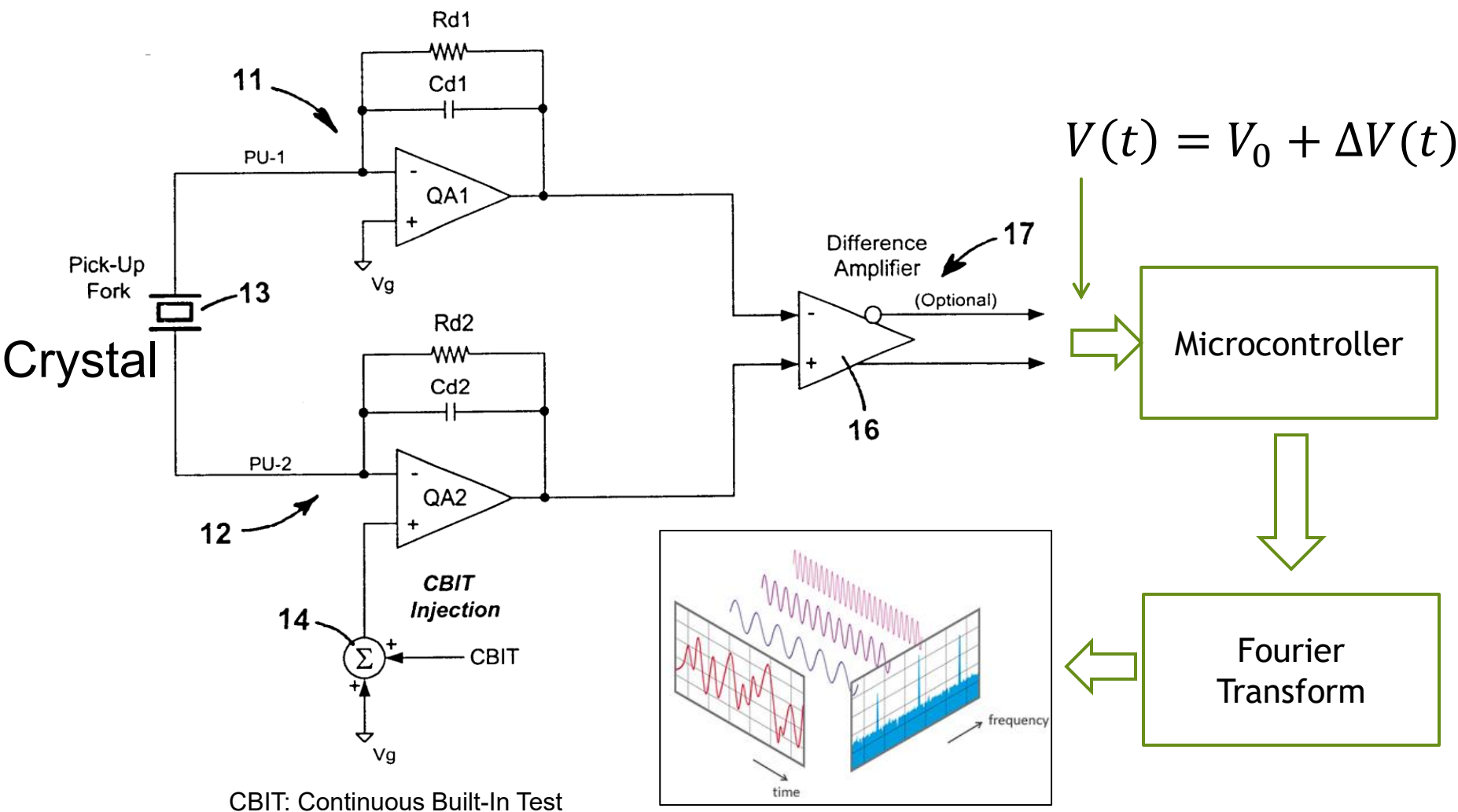

# How to apply principle 2 to design digital measurement and sensing systems for vibration?

- ▶ Vibration is converted to periodic change of AC voltage's magnitude, which is then converted into periodic signal of DC voltage. DC voltage is measured by digital voltmeter (e.g. microcontrollers).

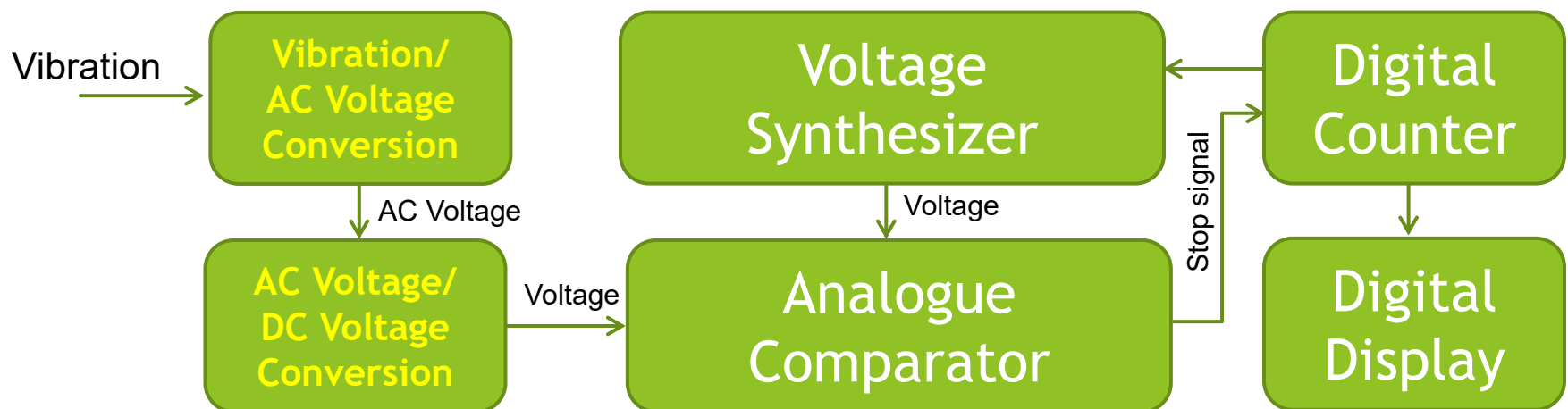

All microcontrollers are programmable digital sensors of voltage!

# What is Eddy Current?

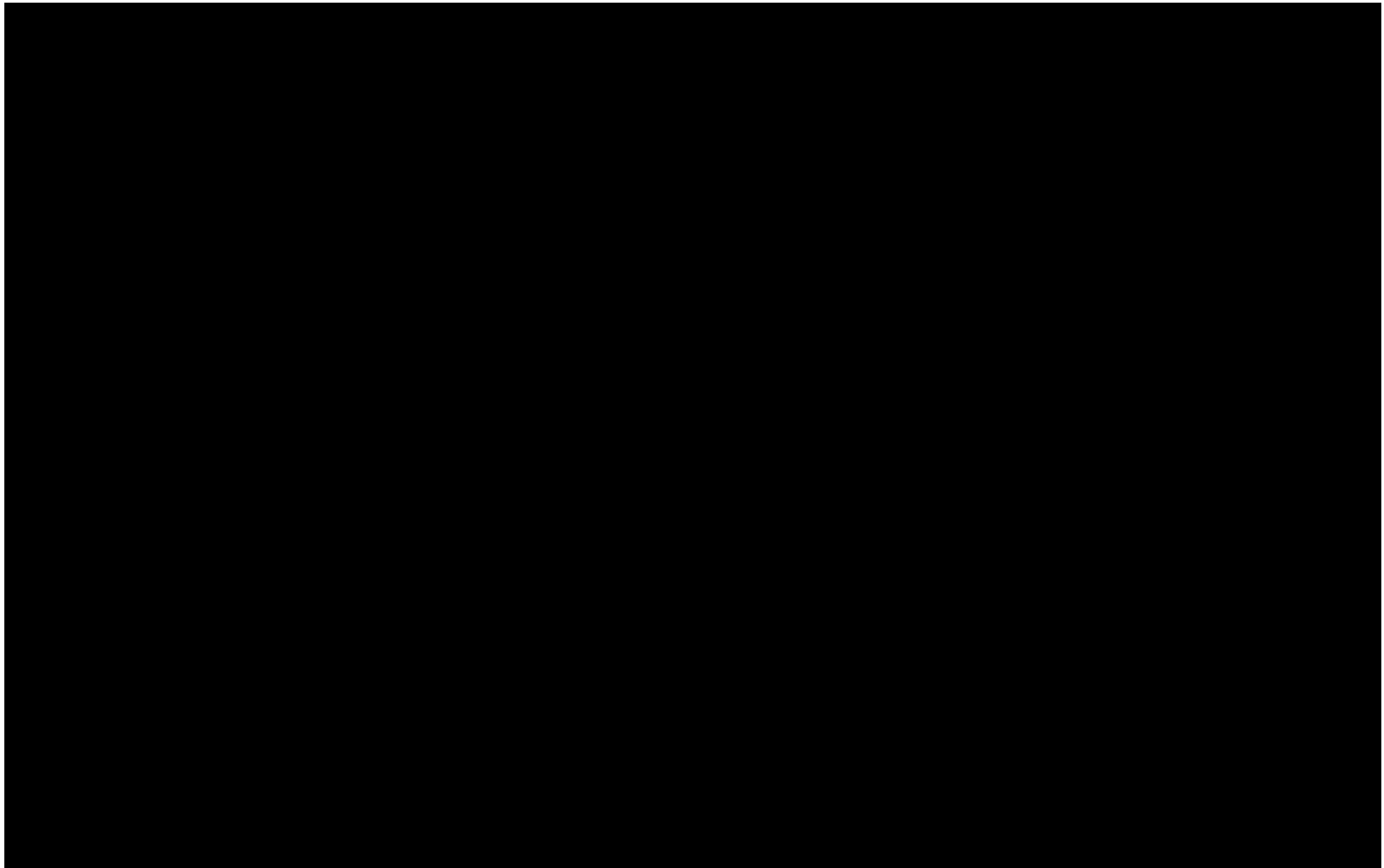

# Application of Eddy Current

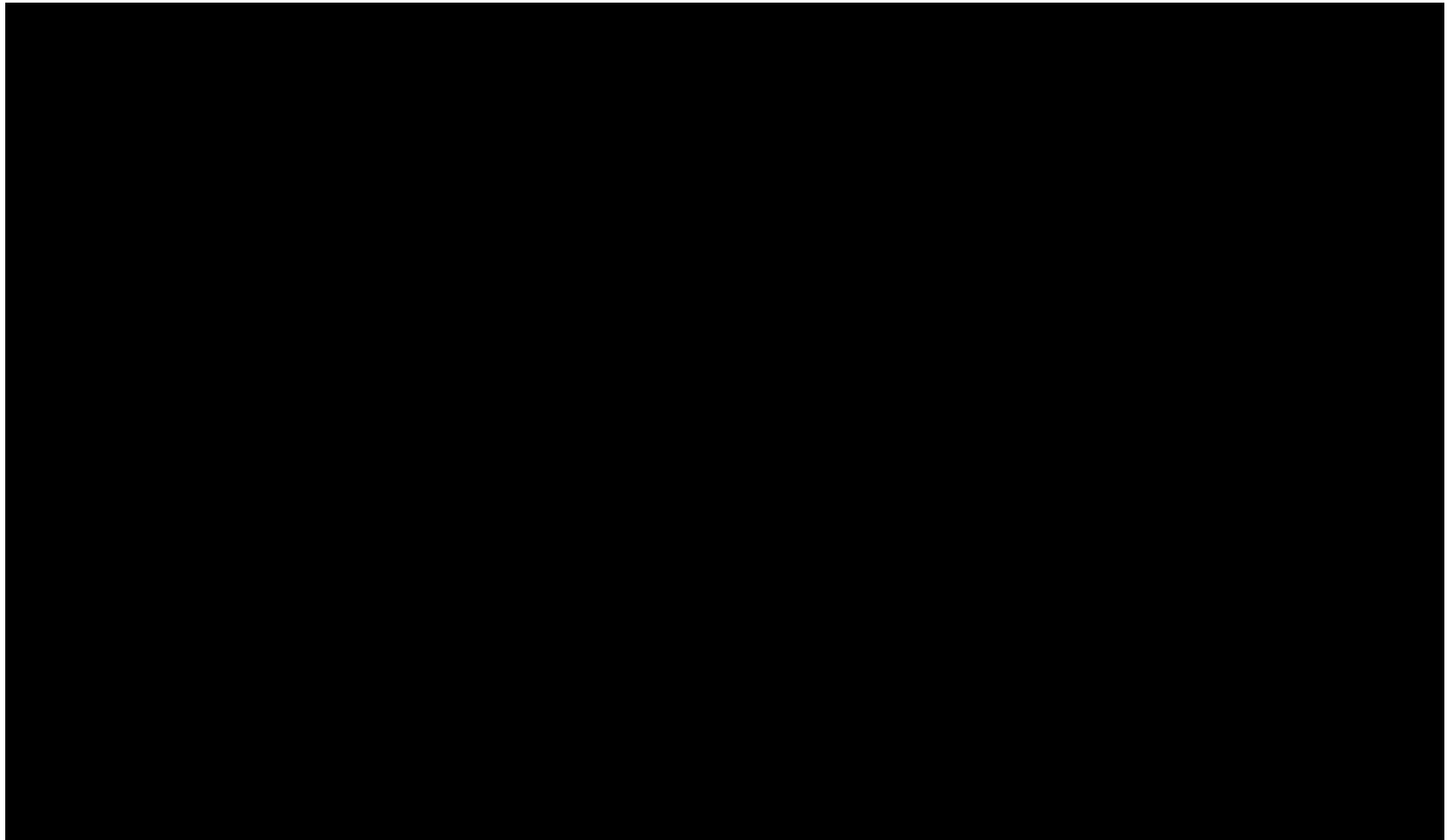

# How to convert vibration into AC voltage?

## To use Eddy Current Effect

- ▶ Alternating current in a **sending coil** could produce alternating magnetic field.
- ▶ Alternating magnetic field could produce alternating Eddy current on conductive materials.
- ▶ Alternating Eddy current could produce alternating magnetic field.
- ▶ Alternating magnetic produced by Eddy current could be converted into alternating voltage or current on a **receiving coil**.

$$v_{out}(t) = A \sin(\omega_v t + \phi_0)$$

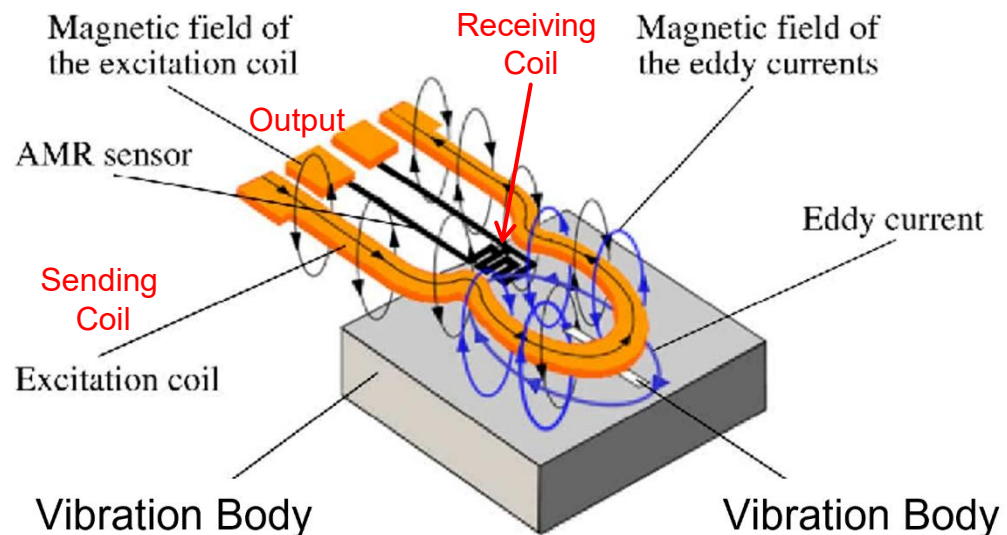
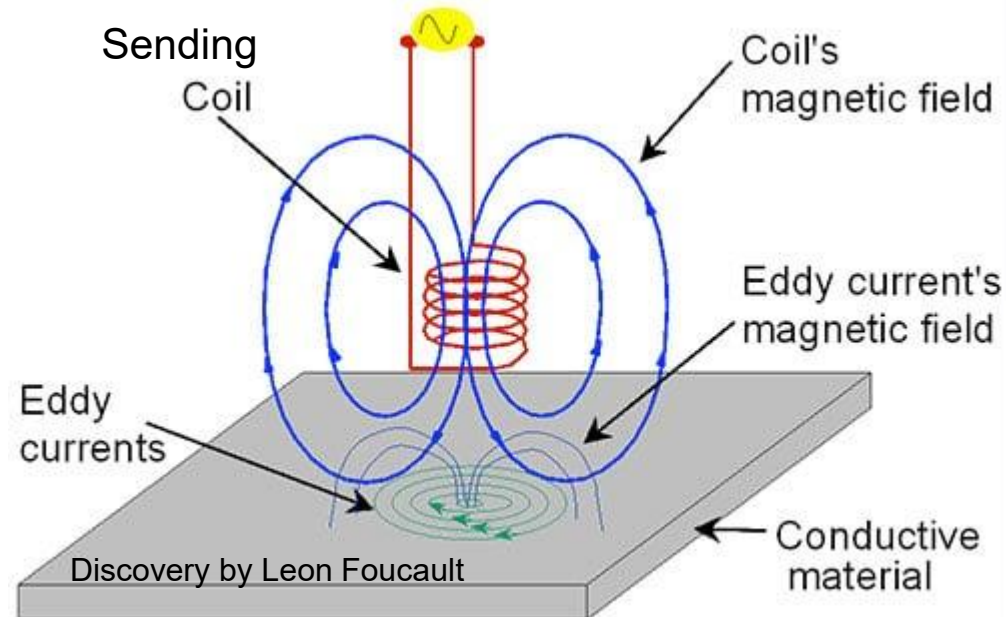

# Example of Vibration Sensor Using Eddy Current Effect

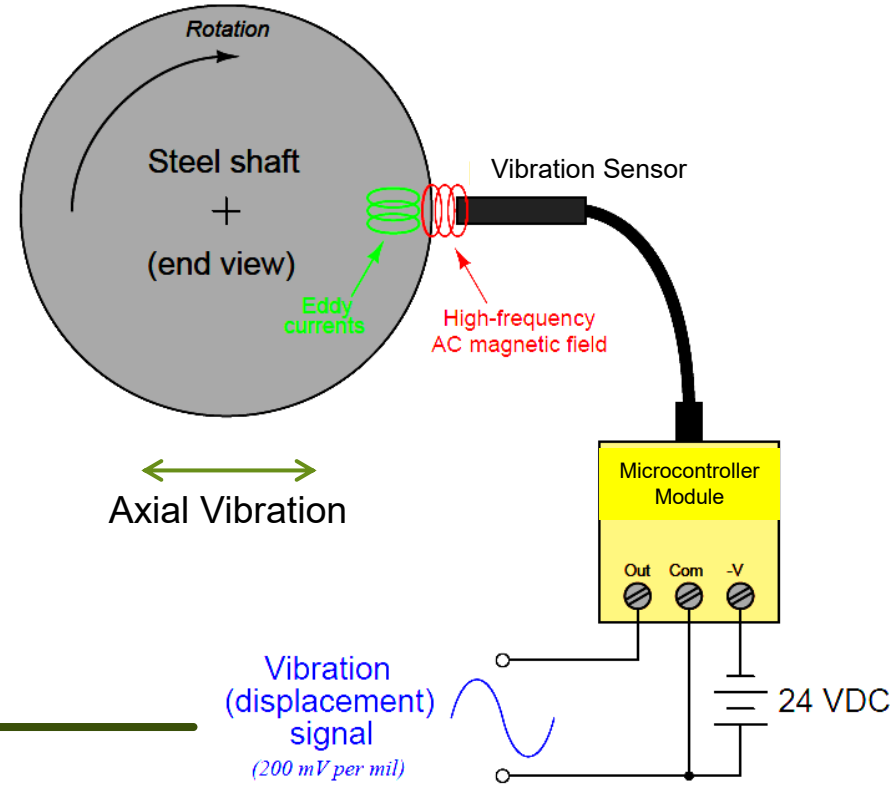

## Eddy Current Principle

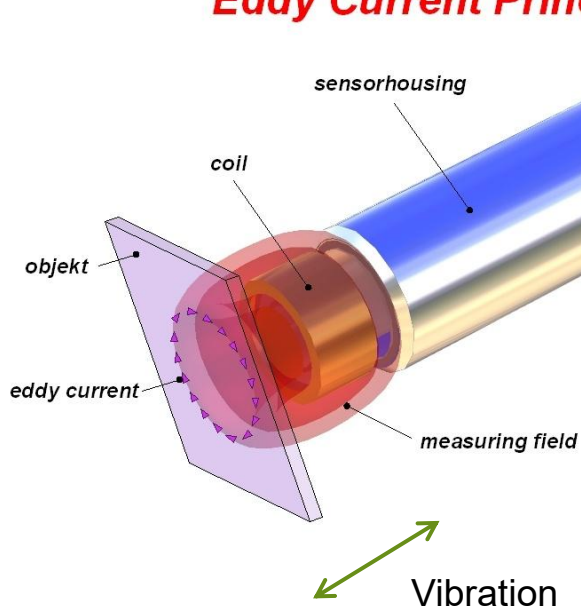

Fourier Transform

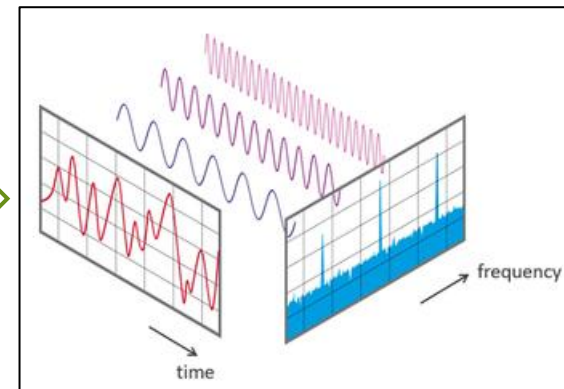

# How to convert AC voltages into DC voltages?

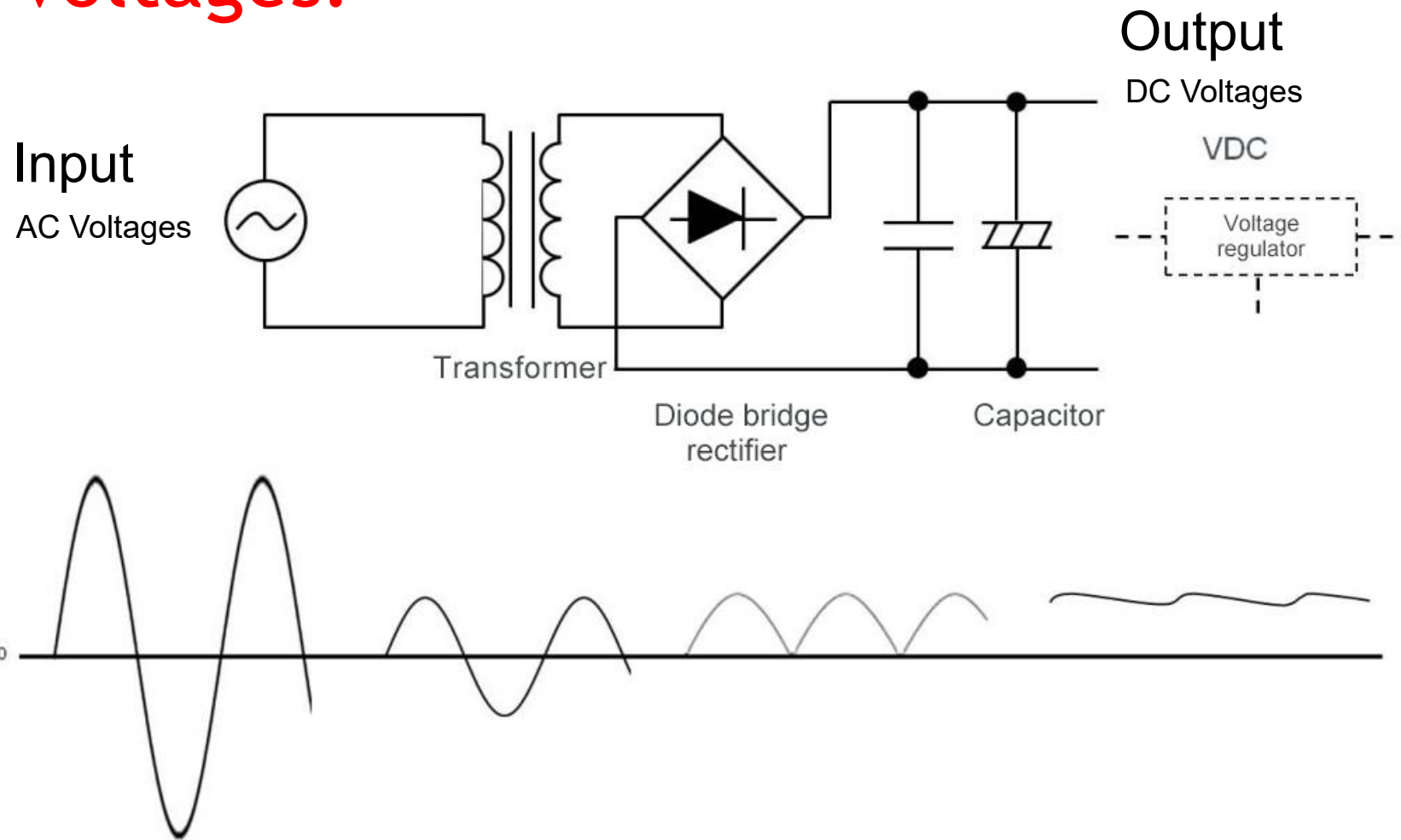

# How to apply principle 3 to design digital measurement and sensing systems for vibration?

- ▶ Vibration is converted to periodic change in resistance, which is then converted into periodic signal of DC voltage. DC voltage is measured by digital voltmeter (e.g. microcontrollers).

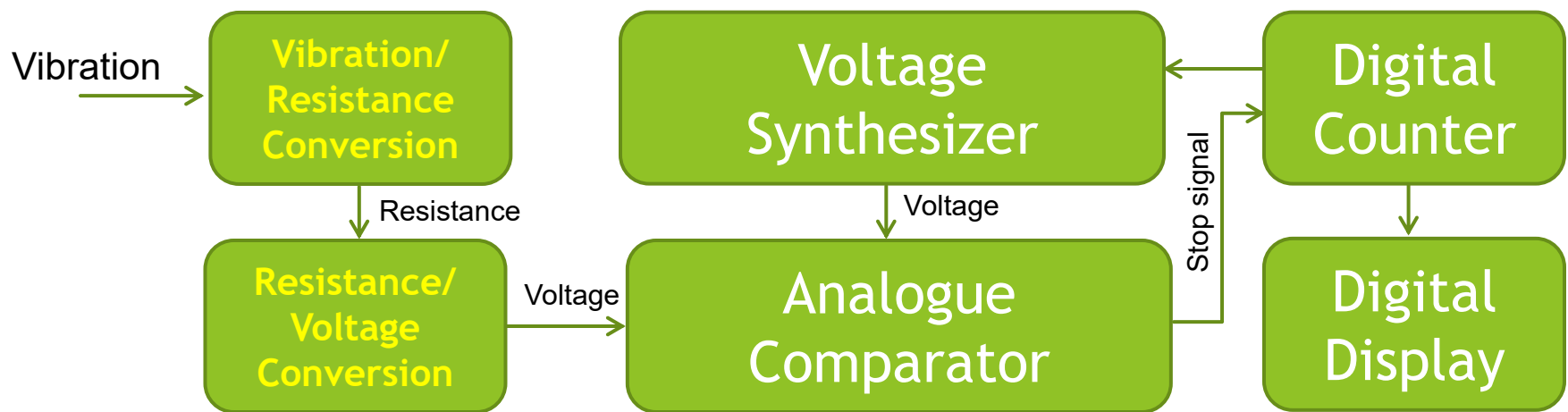

All microcontrollers are programmable digital sensors of voltage!

# How to convert vibration into periodic change in resistance?

- ▶ Strain gauges are placed on cantilever beam, which is fixed at one end and carries a seismic mass at the other end. The seismic mass vibrates together with a vibration source. Then, vibration is converted into periodic change of resistance of strain gauges.

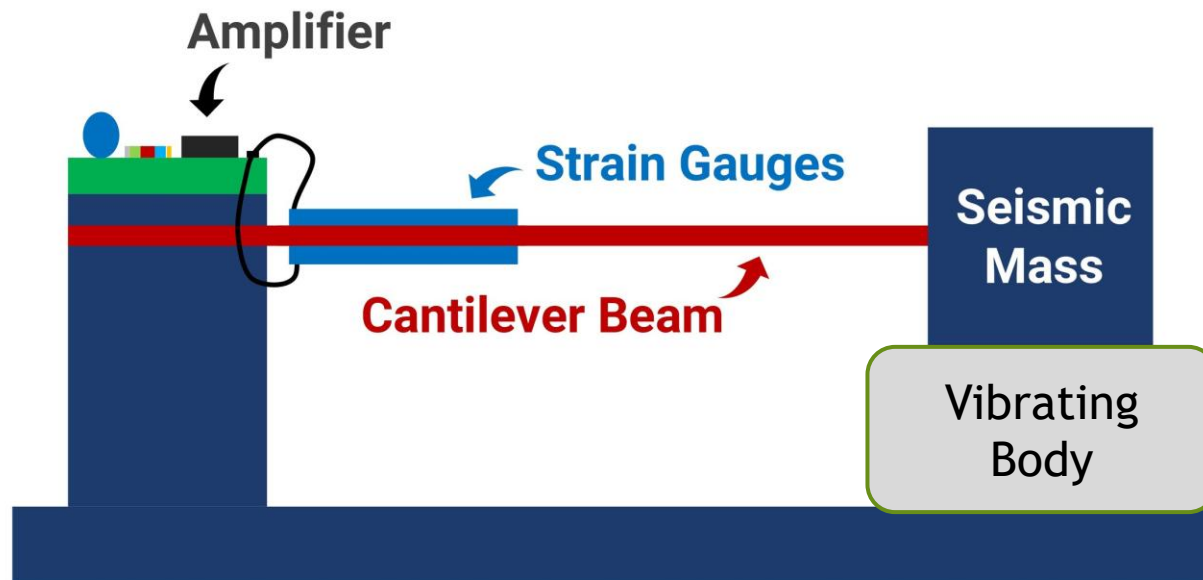

## Other design principles ...

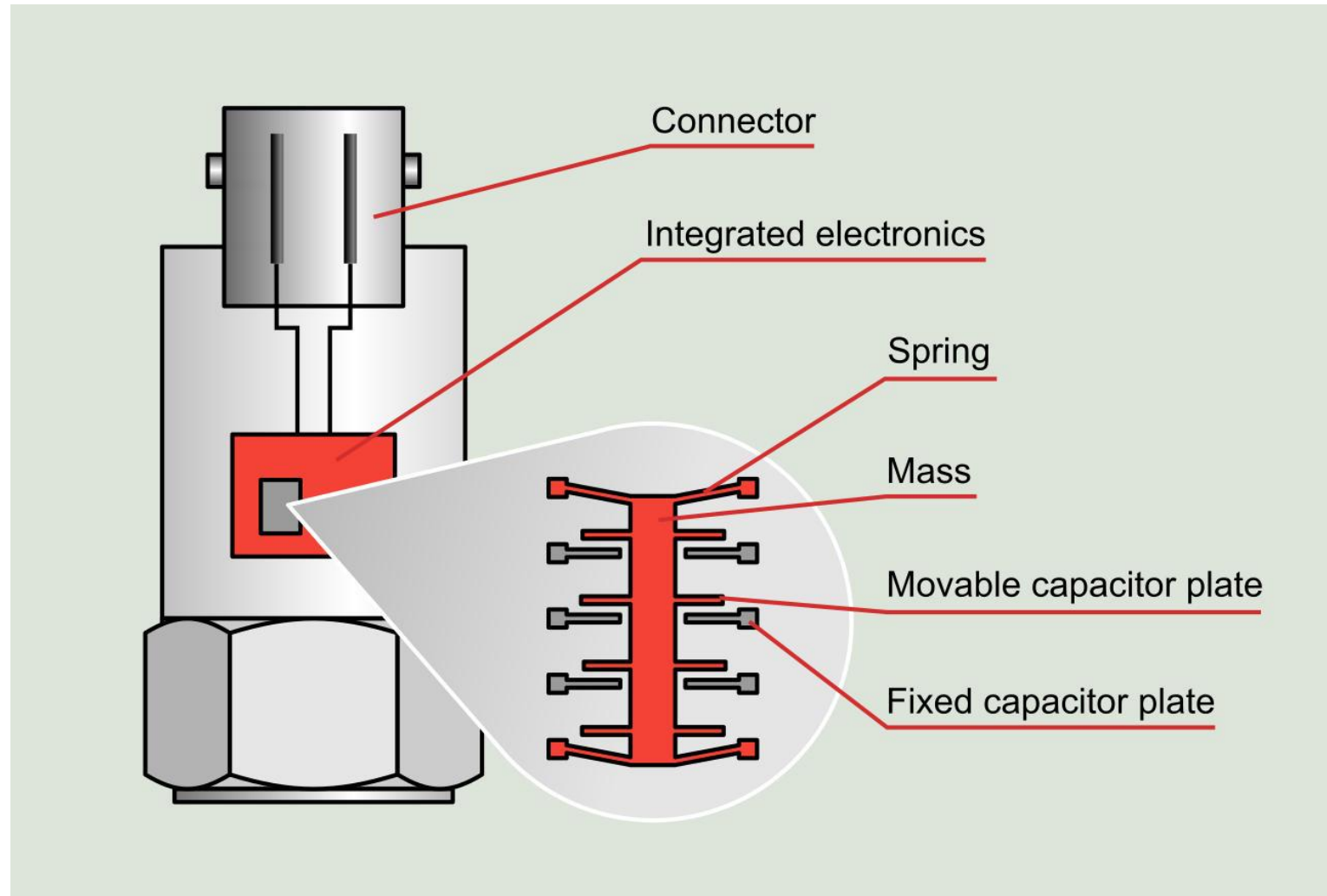

# Remember to Do Calibration

► Curve fitting for calibration:

- $Y_i$  is produced by  $X_i$
- $Z_i$  is computed from  $Y_i$
- $Z_i$  must be equal to  $X_i$

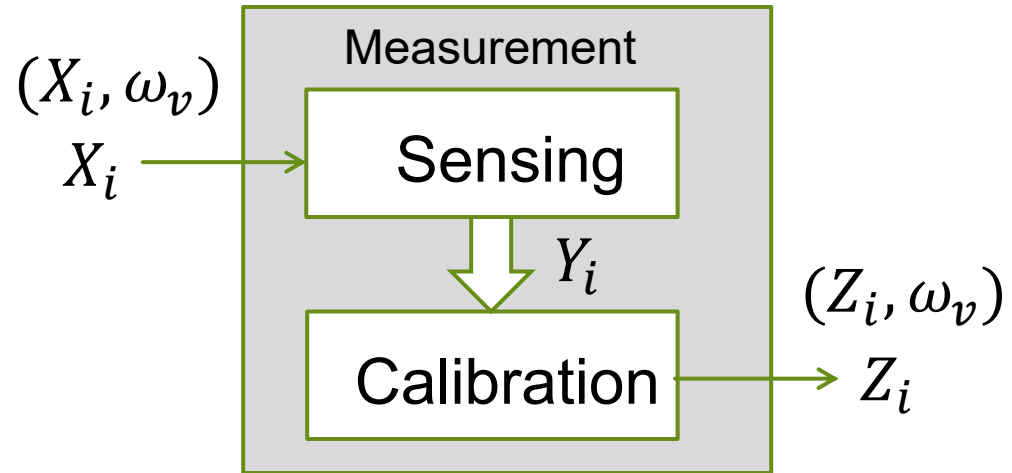

Calibrated Values  $Z_i$

Measured Values  $Y_i$

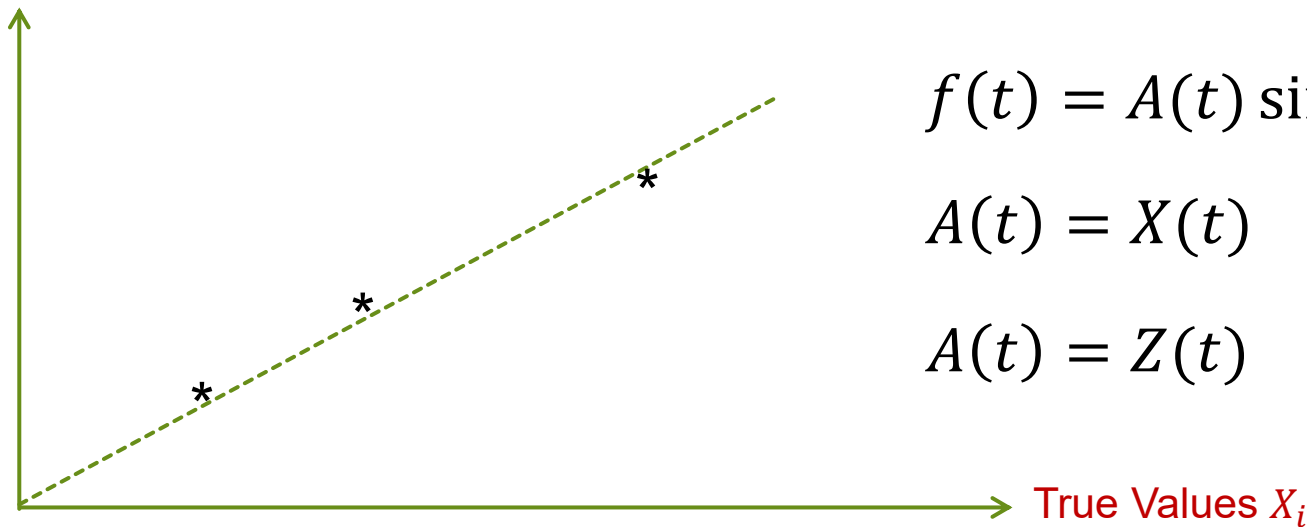

$$f(t) = A(t) \sin(\omega_v t + \phi_0)$$

$$A(t) = X(t) \quad \text{at input}$$

$$A(t) = Z(t) \quad \text{at output}$$

# Remember to Do Error Analysis

- ▶ Systematic error = mean value - true value
- ▶ Repeatability error = value with maximum error - mean value
- ▶ Accuracy = value with minimum error - mean value
- ▶ Hysteresis error = |measured value in increasing - measured value in decreasing|

For each true value, we can do error analysis

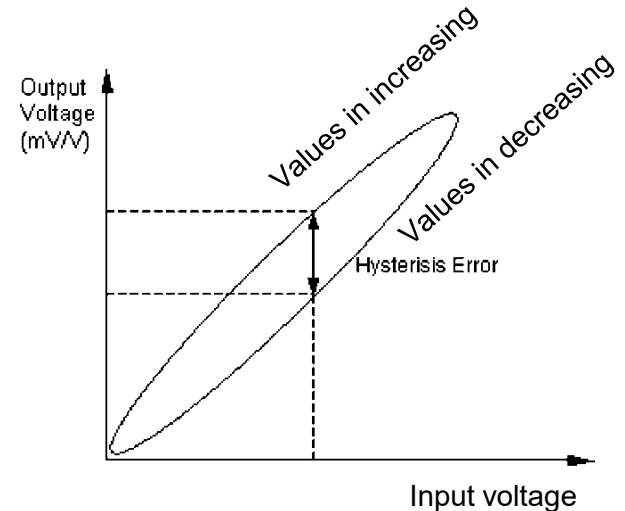
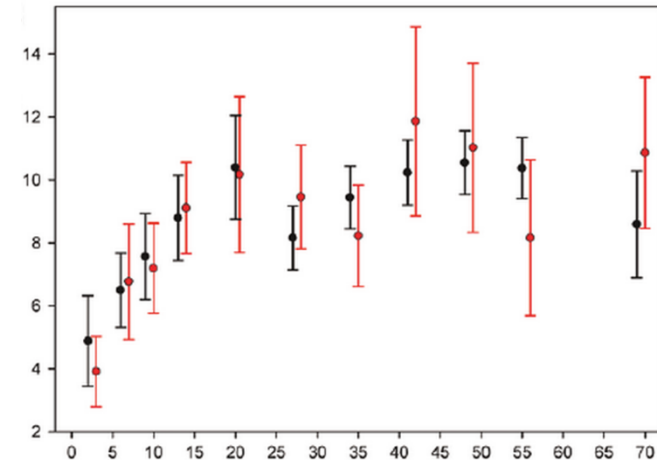

# Summary

- ▶ Understanding of Vibration
- ▶ Computation of Vibration
- ▶ Measurement of Vibration

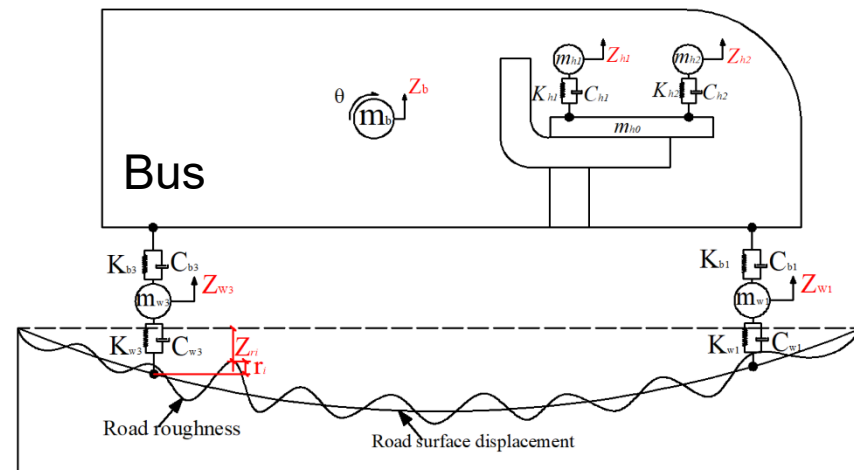
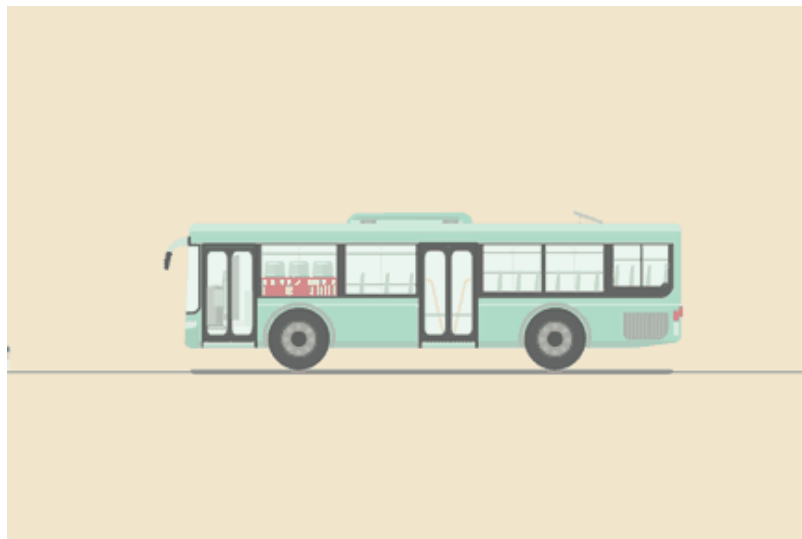

# Outline of Module 4

- ▶ Lecture 1:
  - ▶ Measurement of Pressure
- ▶ Lecture 2:
  - ▶ Measurement of Temperature
- ▶ Lecture 3:
  - ▶ Measurement of Humidity
- ▶ Lecture 4:
  - ▶ Measurement of Vibration
- ▶ Lecture 5:
  - ▶ Measurement of Air Quality

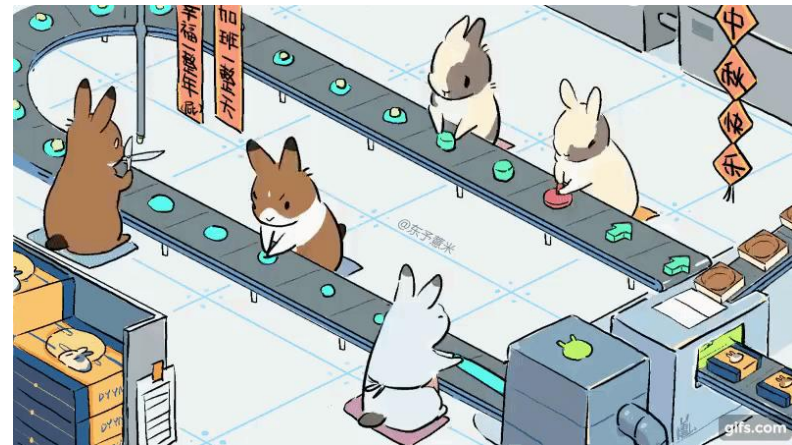



**NANYANG**  
**TECHNOLOGICAL**  
**UNIVERSITY**

School of Mechanical & Aerospace Engineering

Design, Machine, Control, Intelligence

Module 4 Lecture 5

MA4822

# Measurement of Air Quality

Xie Ming, PhD (France)

[mmxie@ntu.edu.sg](mailto:mmxie@ntu.edu.sg)

<http://personal.ntu.edu.sg/mmxie>

# Outline

- ▶ Concept of Active Sensing
- ▶ Understanding of Air Pollutants
- ▶ Parameter(s) of Dust in Air
- ▶ Measurement of Dust in Air

Carbon Monoxide  
Carbon Dioxide  
Nitrogen Oxide  
Sulphur Dioxide  
Volatile Organic Compounds  
**Particulate Matters**

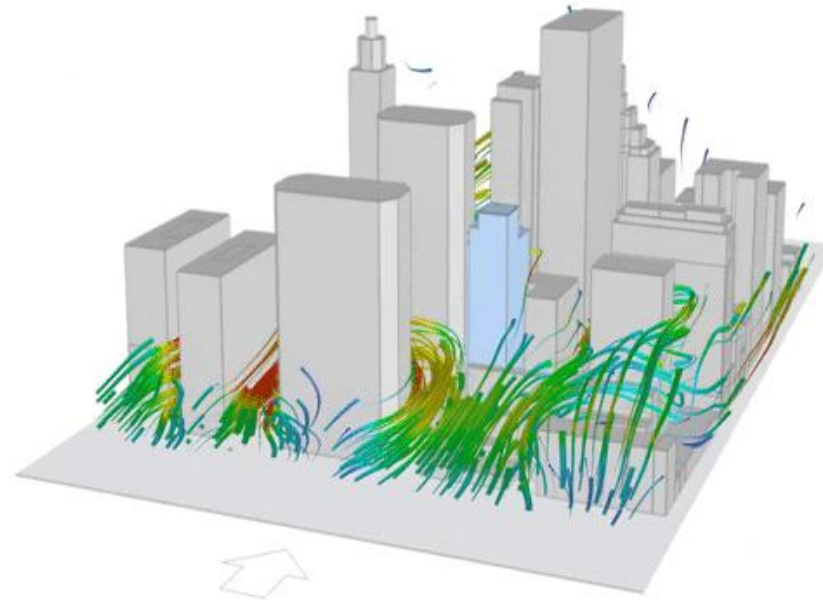
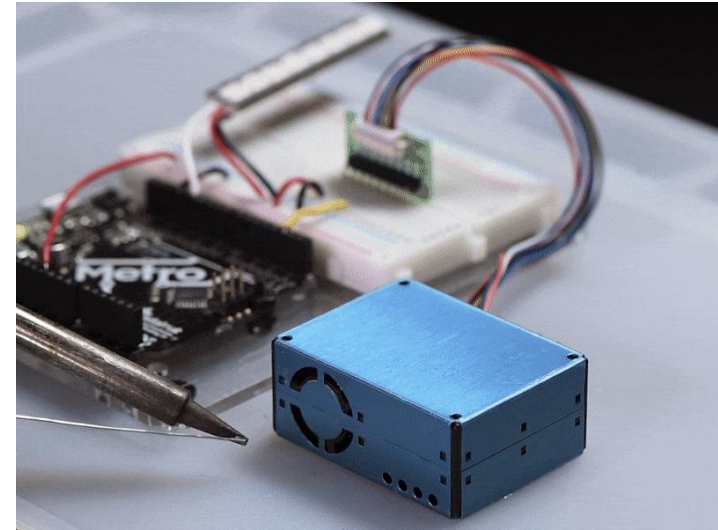

# Outline

- ▶ Concept of Active Sensing
- ▶ Understanding of Air Pollutants
- ▶ Parameter(s) of Dust in Air
- ▶ Measurement of Dust in Air

Carbon Monoxide  
Carbon Dioxide  
Nitrogen Oxide  
Sulphur Dioxide  
Volatile Organic Compounds  
**Particulate Matters**

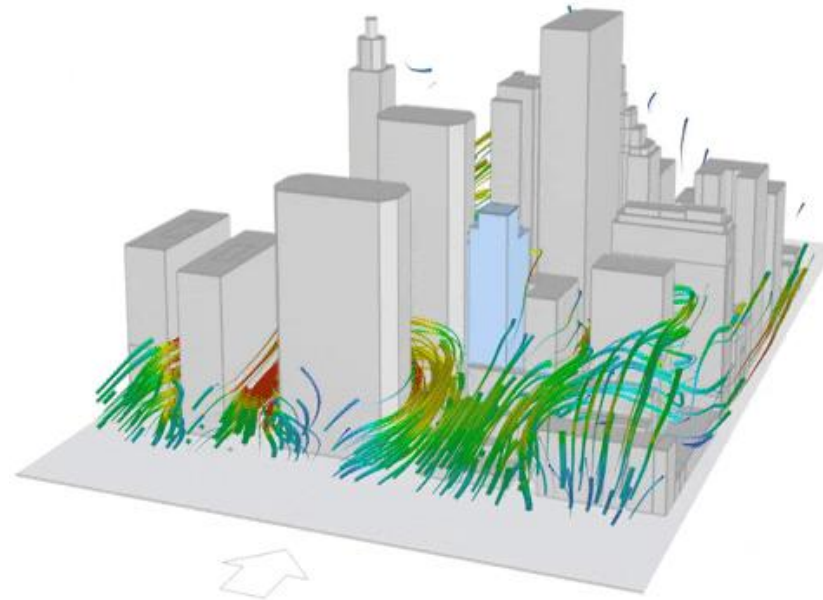
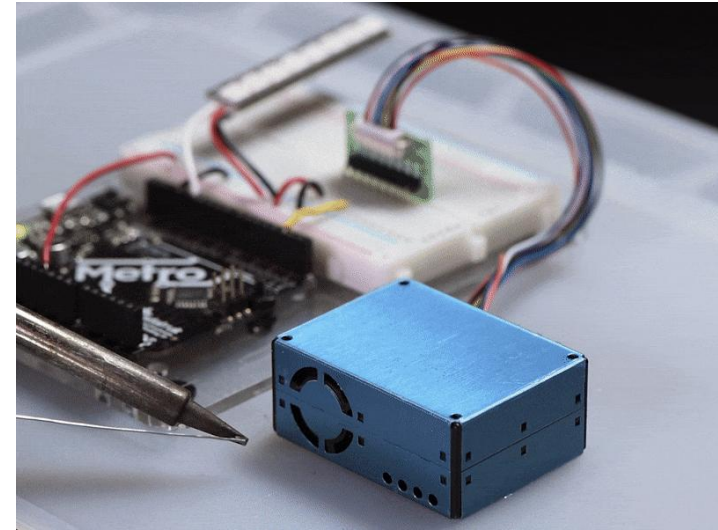

# Definition of Active Sensing

- ▶ The use of external signals (e.g. waves) to capture the values of a physical quantity under measurement is called active sensing.

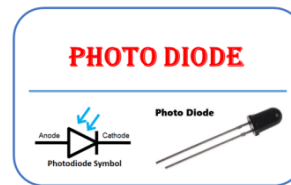
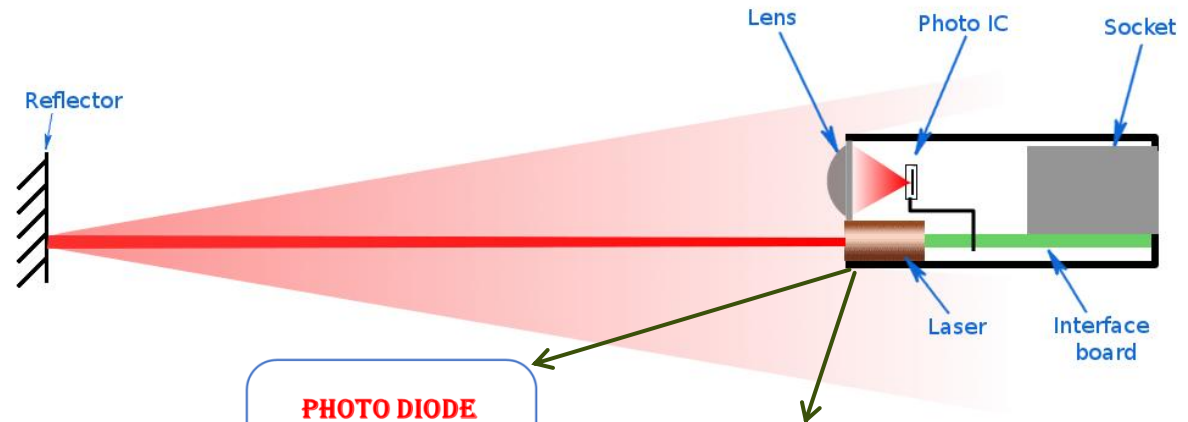
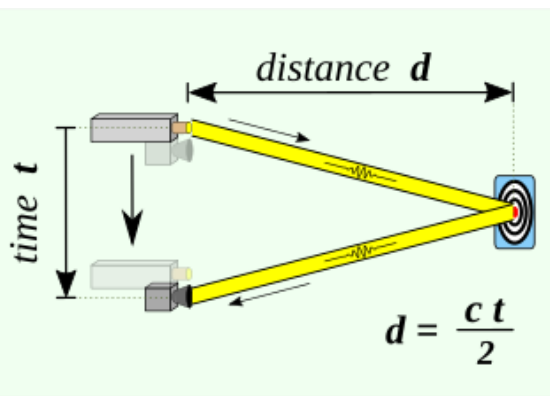

## Pyroelectric materials

- Two strips of pyroelectric material (a pyroelectric sensor)
- An infrared filter (that blocks out all other wavelengths of light)
- A fresnel lens (which collects light from many angles into a single point)
- A housing unit (to protect the sensor from other environmental variables, such as humidity)

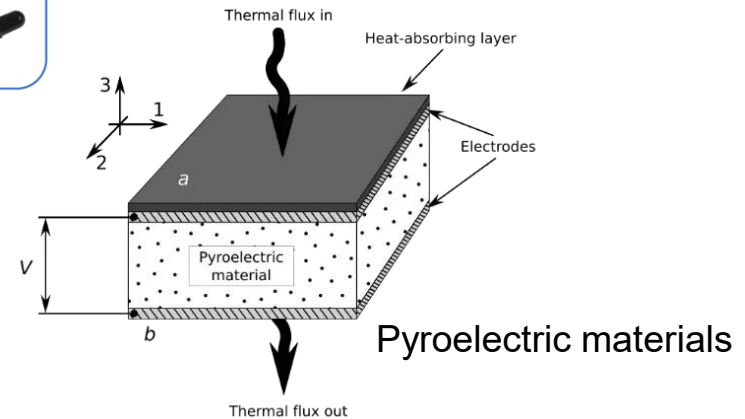

# Typical External Signals ...

## Acoustic Waves

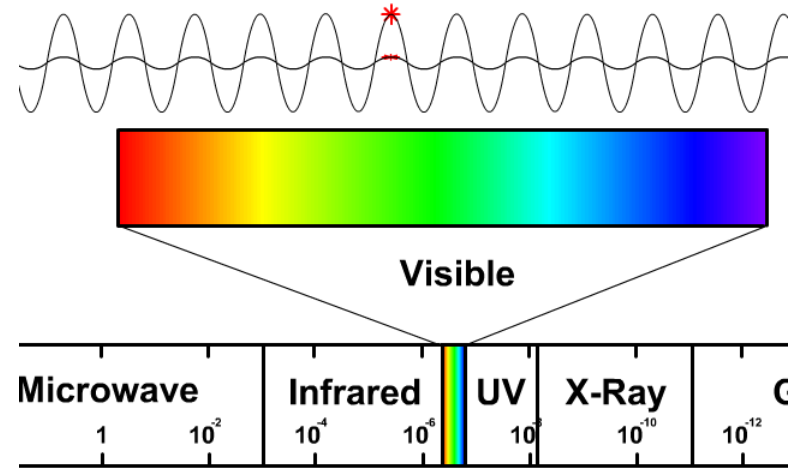
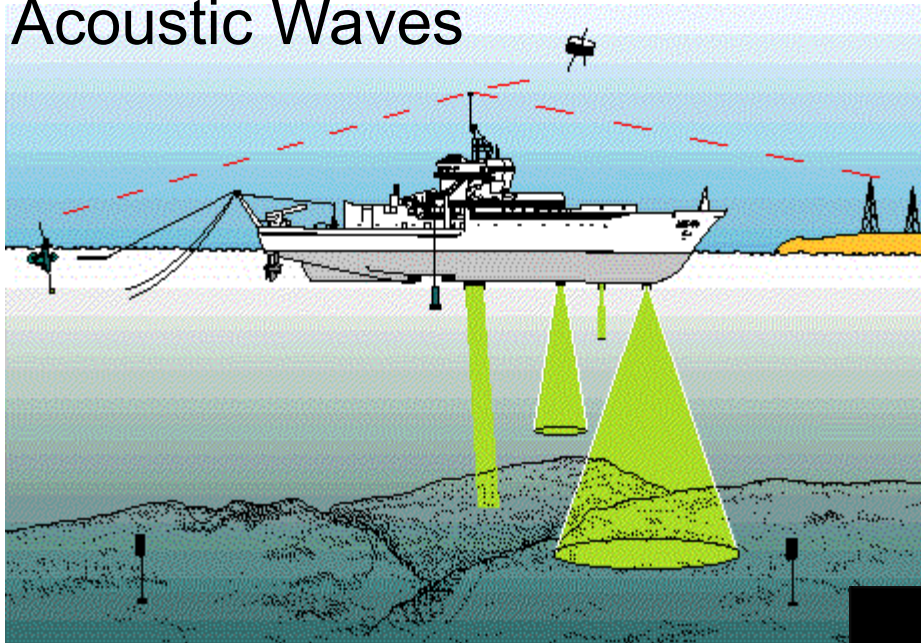

## Electromagnetic Waves

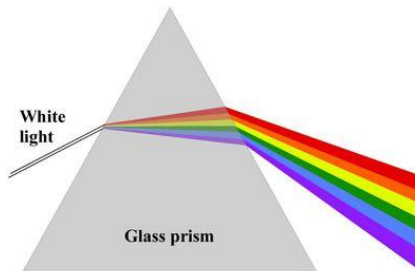

Color	$\lambda$ (nm)	Freq (Hz)
Red	760-647	$4.3 \times 10^{14}$
Orange	647-585	$4.3 \times 10^{14}$
Yellow	585-575	$5.2 \times 10^{14}$
Green	575-491	$5.6 \times 10^{14}$
Blue	491-424	$6.6 \times 10^{14}$
Violet	424-380	$7.3 \times 10^{14}$

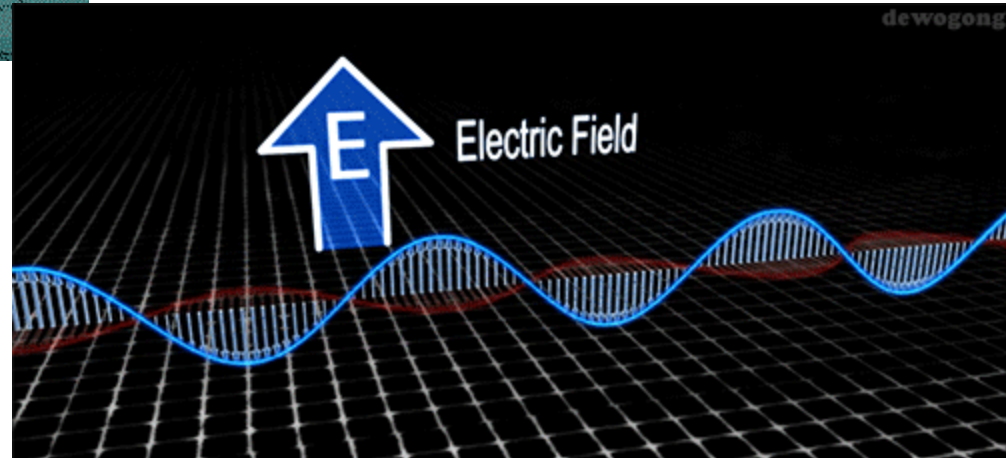

# Outline

- ▶ Concept of Active Sensing
- ▶ Understanding of Air Pollutants
- ▶ Parameter(s) of Dust in Air
- ▶ Measurement of Dust in Air

Carbon Monoxide  
Carbon Dioxide  
Nitrogen Oxide  
Sulphur Dioxide  
Volatile Organic Compounds  
**Particulate Matters**

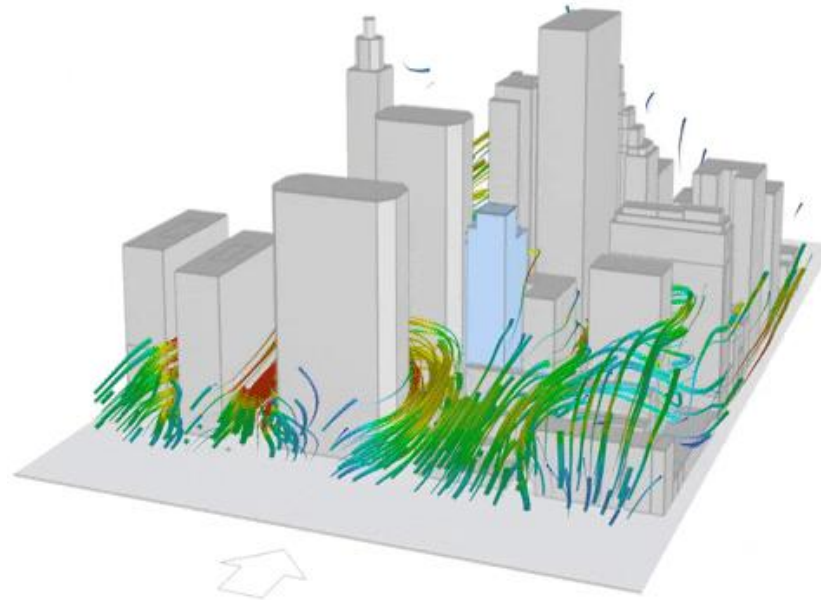
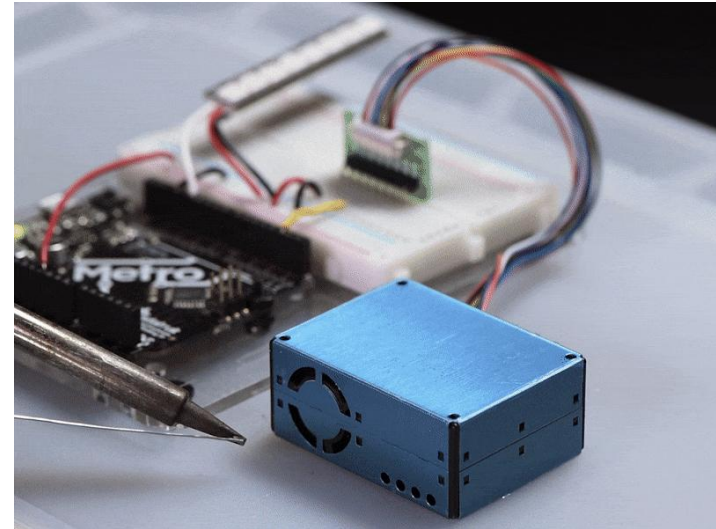

# Air Pollutants ...



# Classification of Air Pollutants

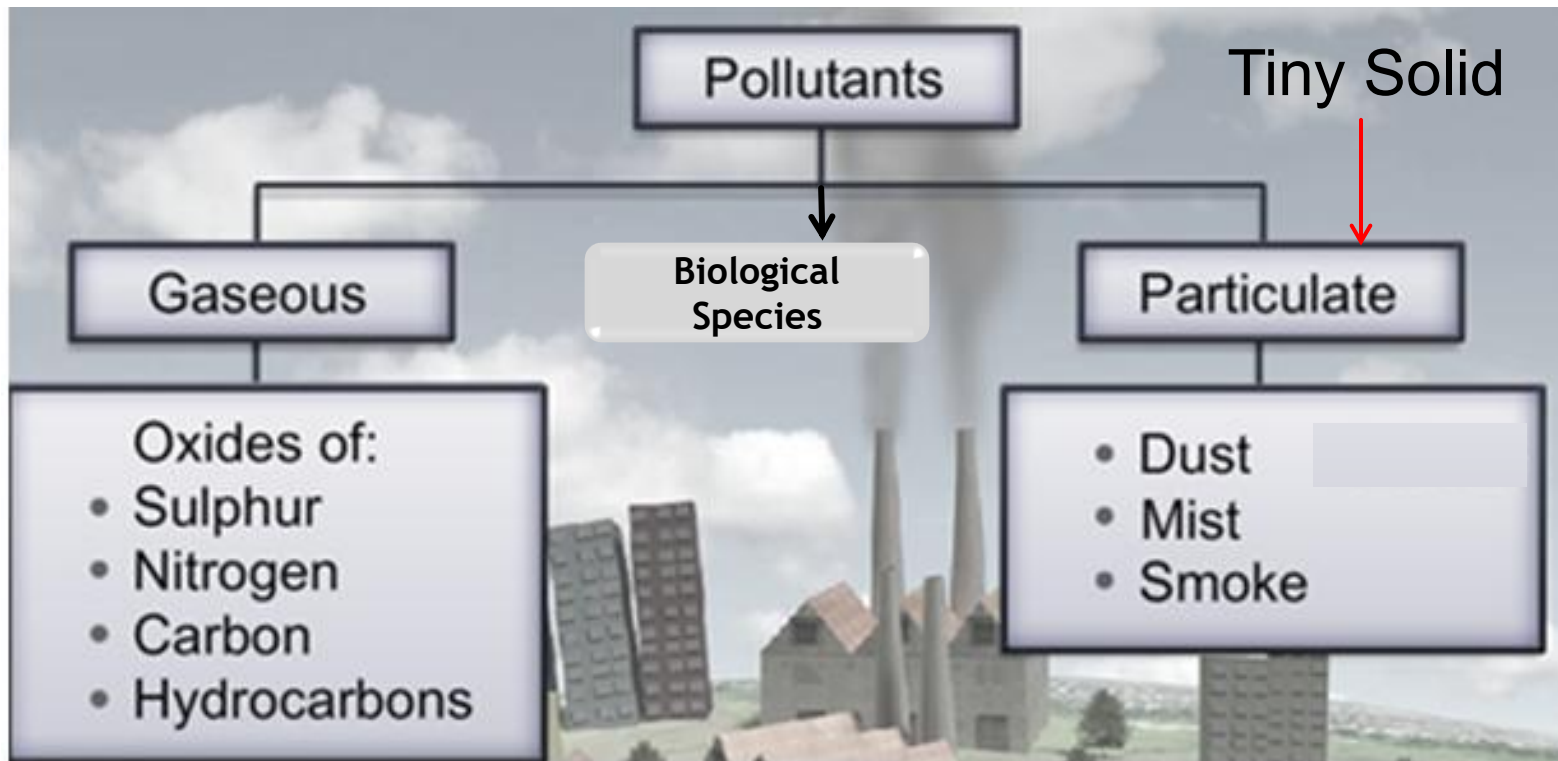

## Primary pollutants

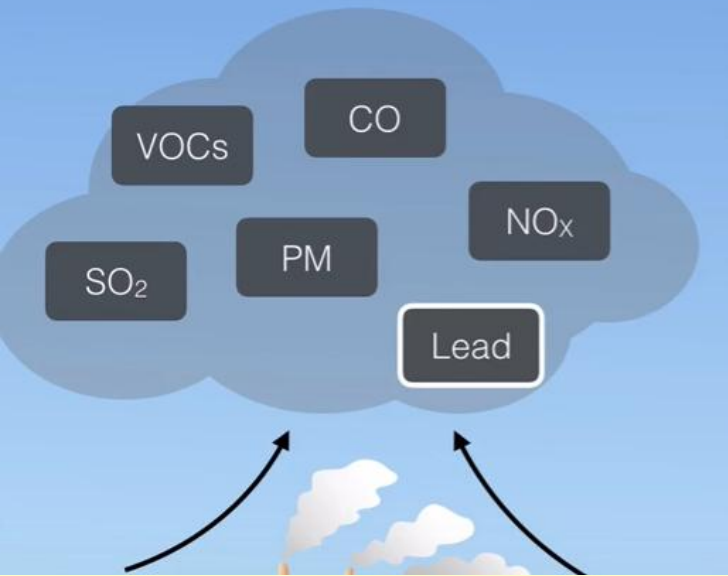

## Secondary Pollutants...Photochemical smog

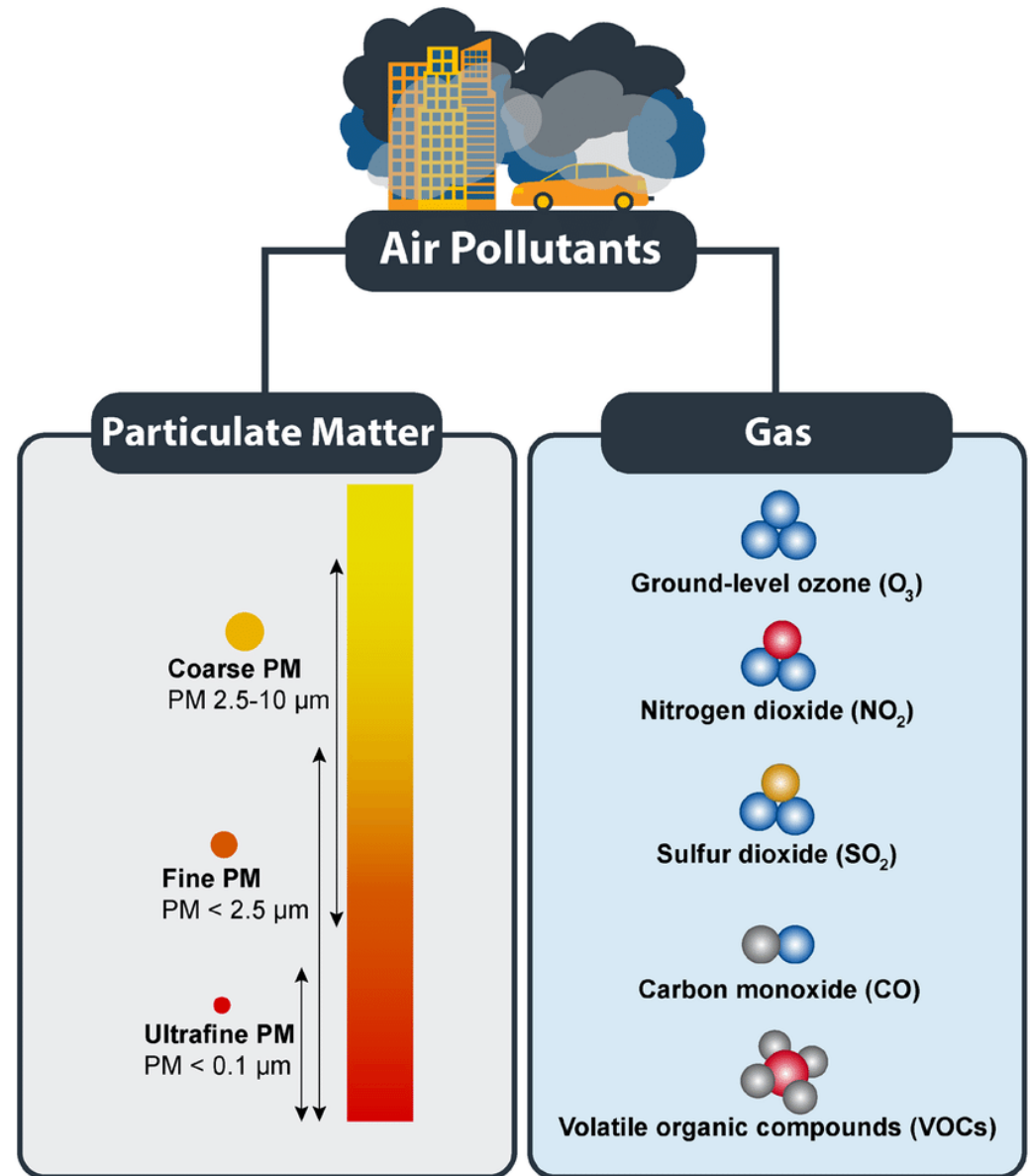
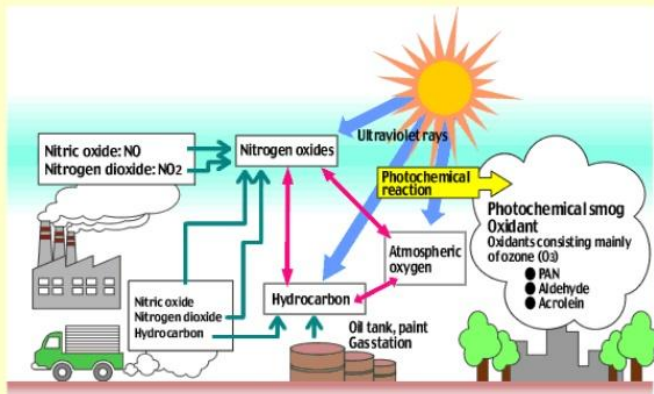

# Source of Pollutants

## OUTDOOR AIR POLLUTION

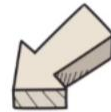

**NATURAL**  
*(biogenic)*

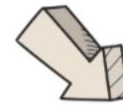
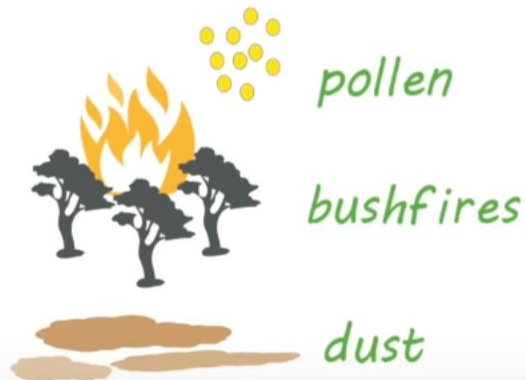

**HUMAN**  
*(anthropogenic)*

*industry*

*burning fossil fuel*

*motor vehicles*



# Examples of Sources of Air Pollutants ...

- Industrial Activities
- Agricultural Activities
- City activities
- Others

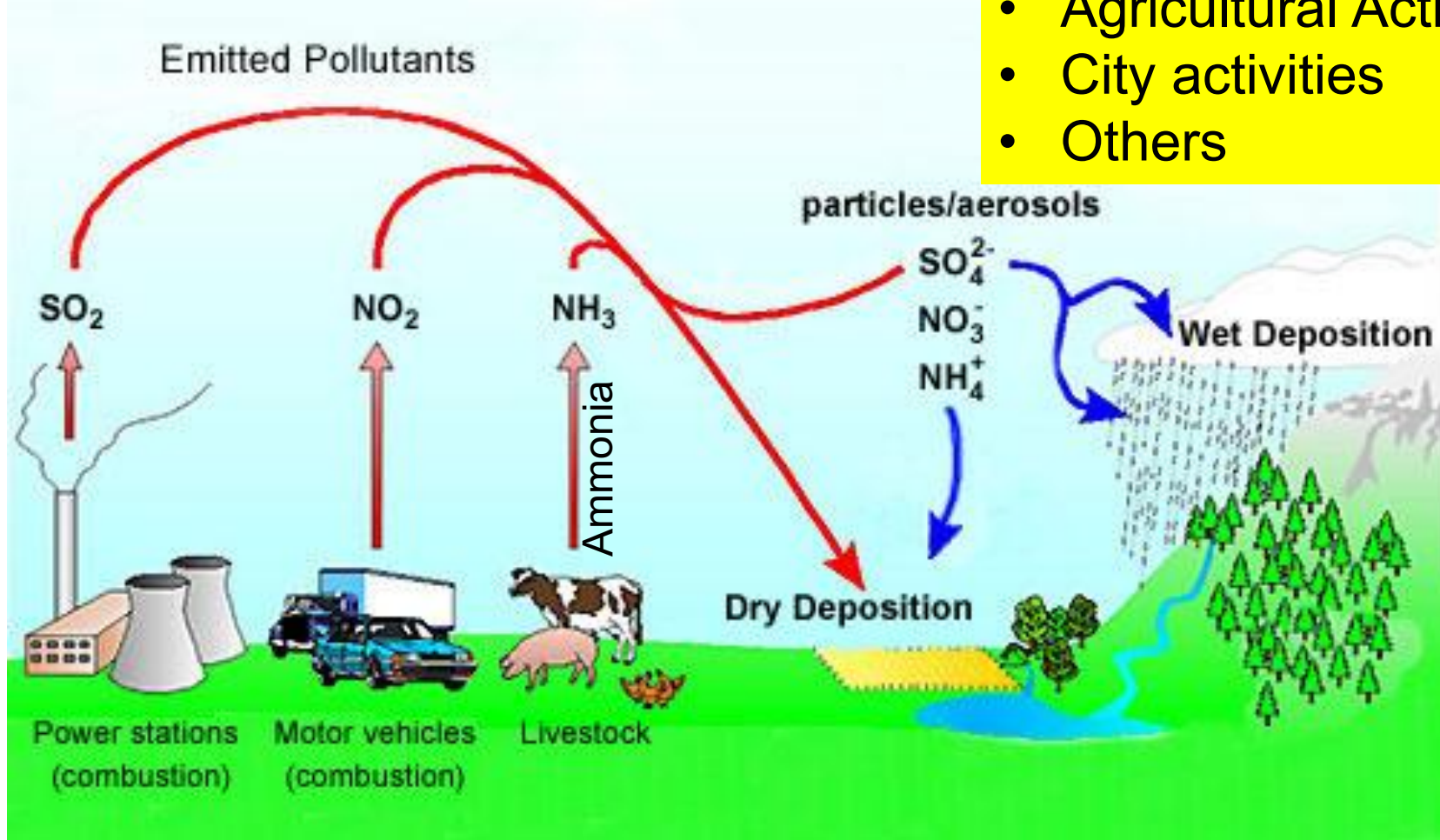

# Scale of Air Pollutants

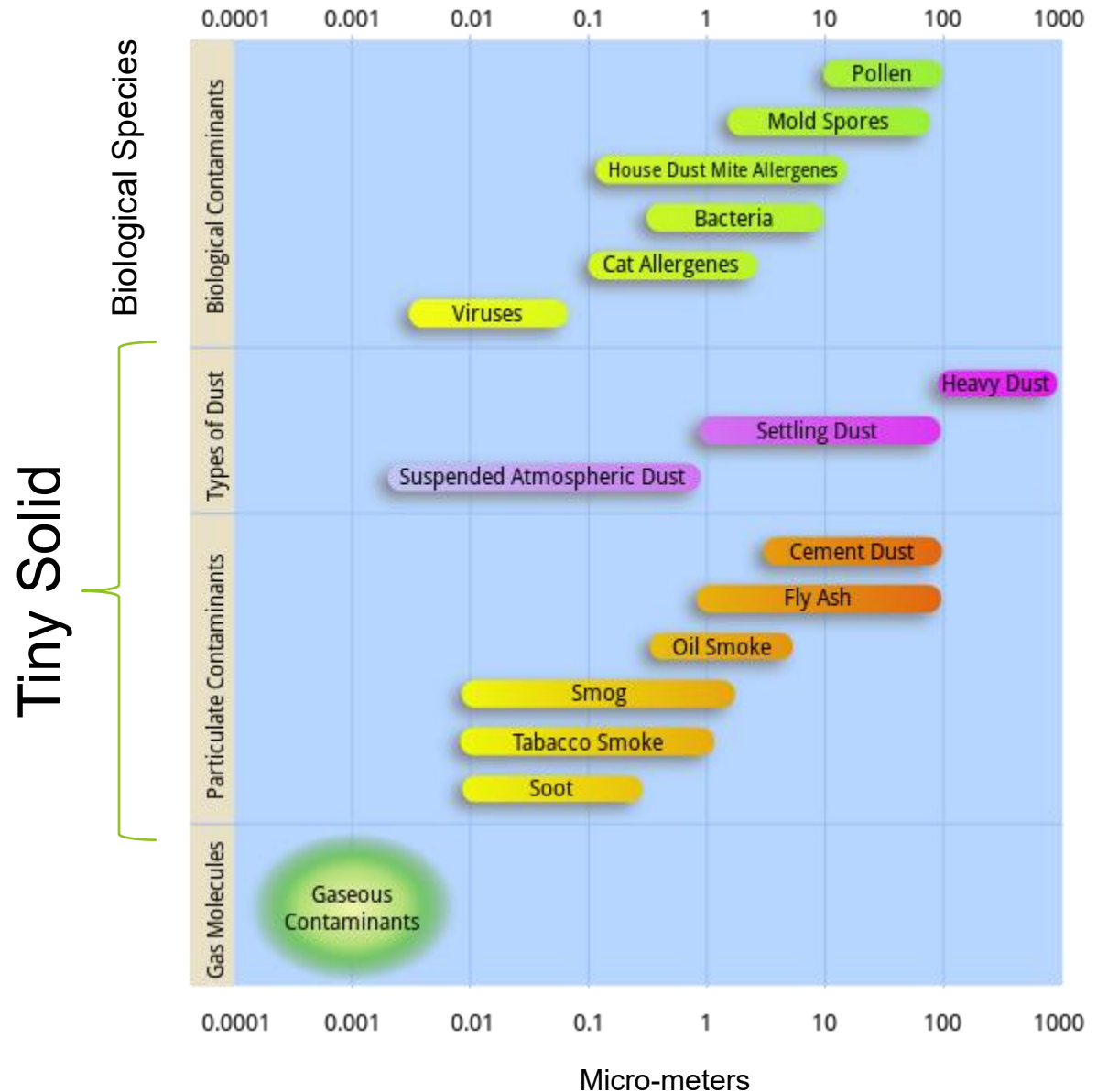
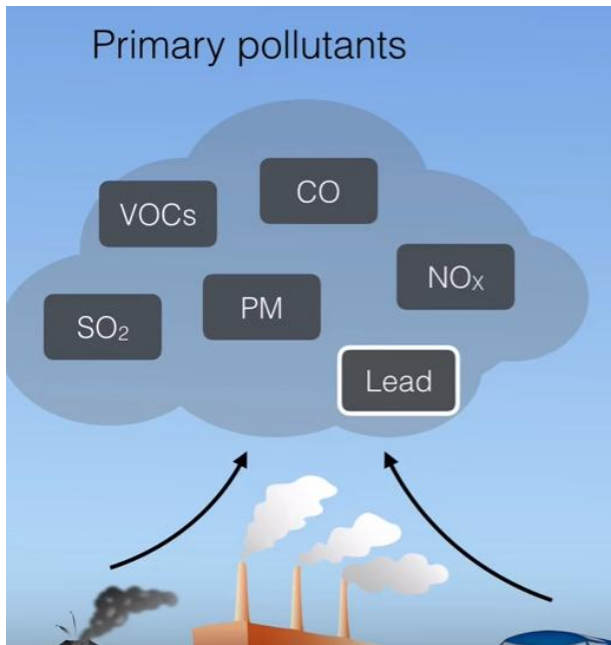

# Gaseous Contaminants

Dioxins/ Furans, Hydrogen Sulphide, Hydrogen Chloride, ...

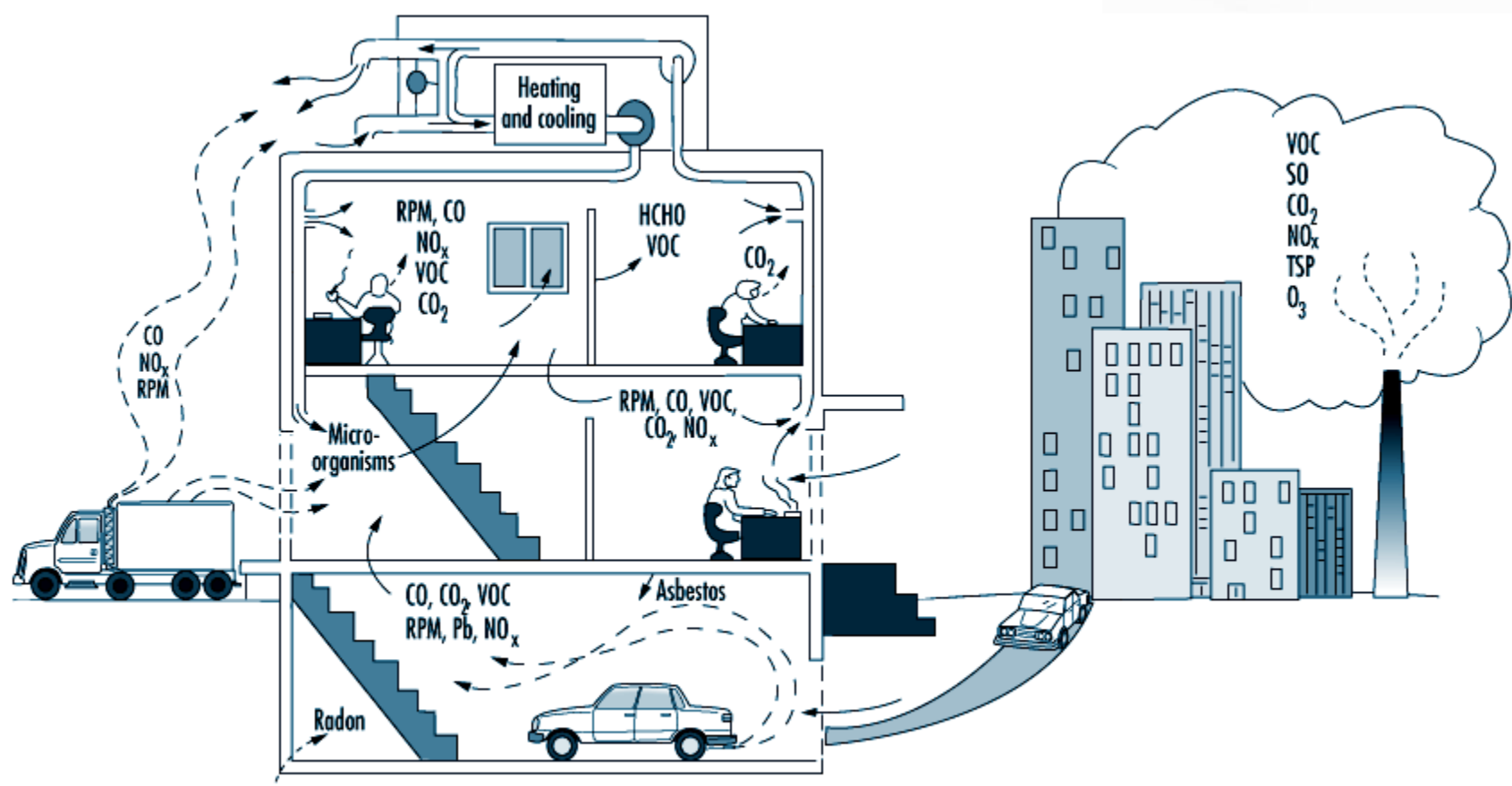

CO = carbon monoxide; CO<sub>2</sub> = carbon dioxide; HCHO = formaldehyde; NO<sub>x</sub> = nitrogen oxides; Pb = lead; RPM = respirable particulate matter; VOC = volatile organic compounds.

# Gaseous Contaminants



# Soot

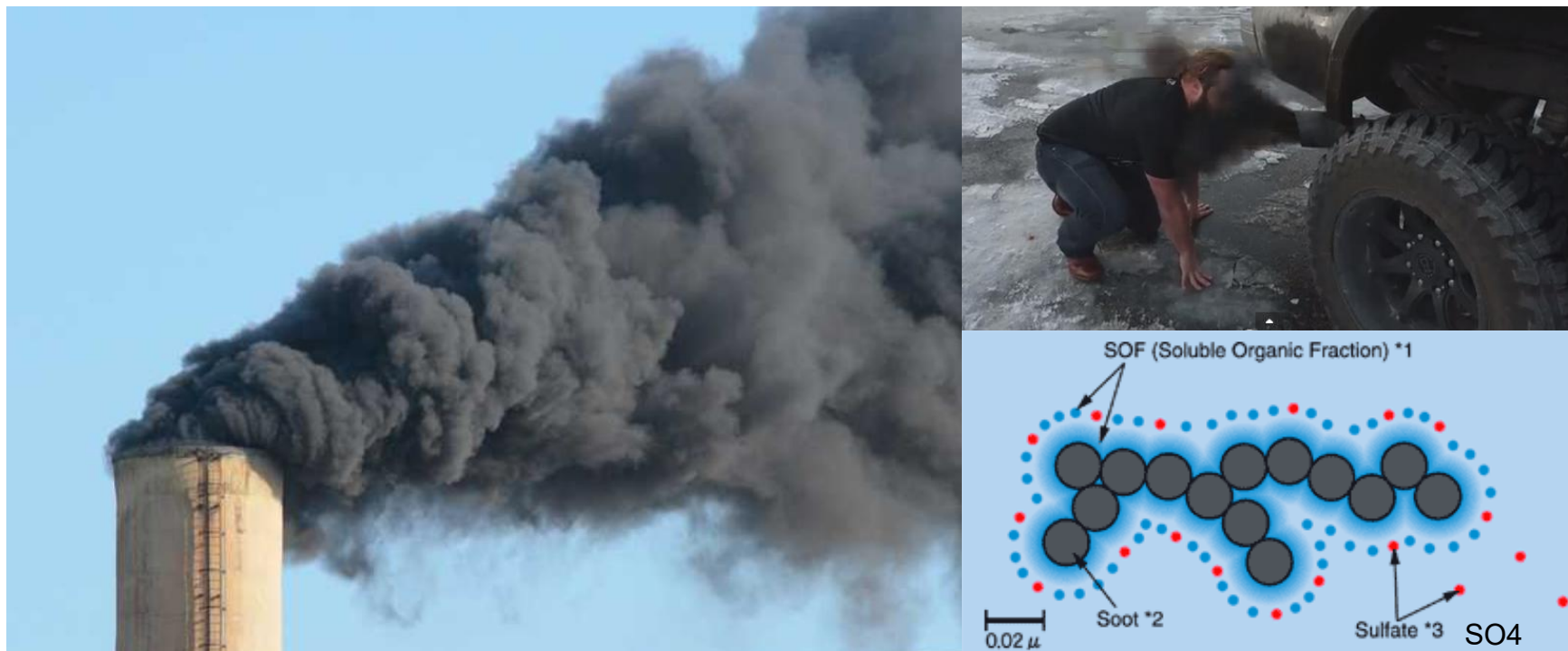

# Smog



# Oil Smoke



# FLYASH BRICK MAKING MACHINE Schematic Diagram

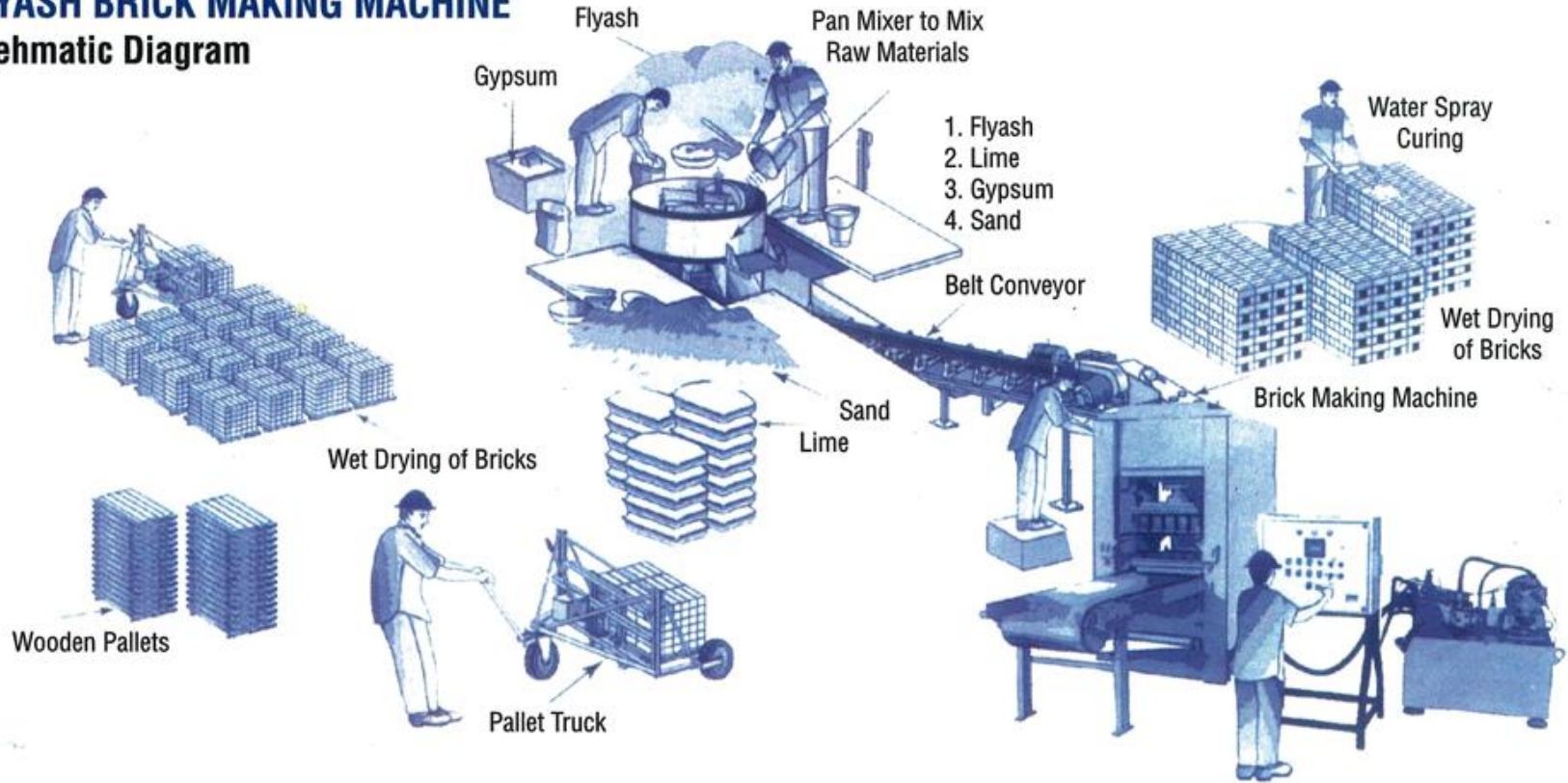

# Fly Ash

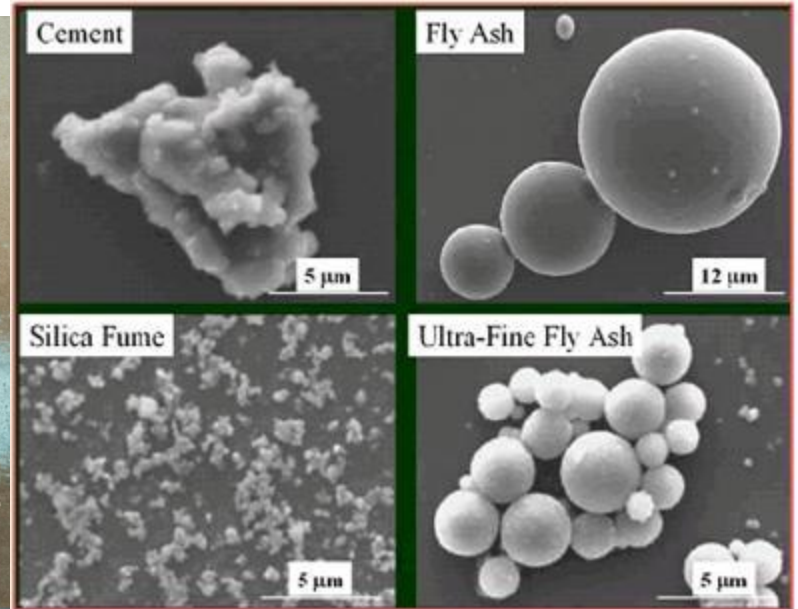

Fly Ash is a fine powder with a similar particle size distribution as Portland cement

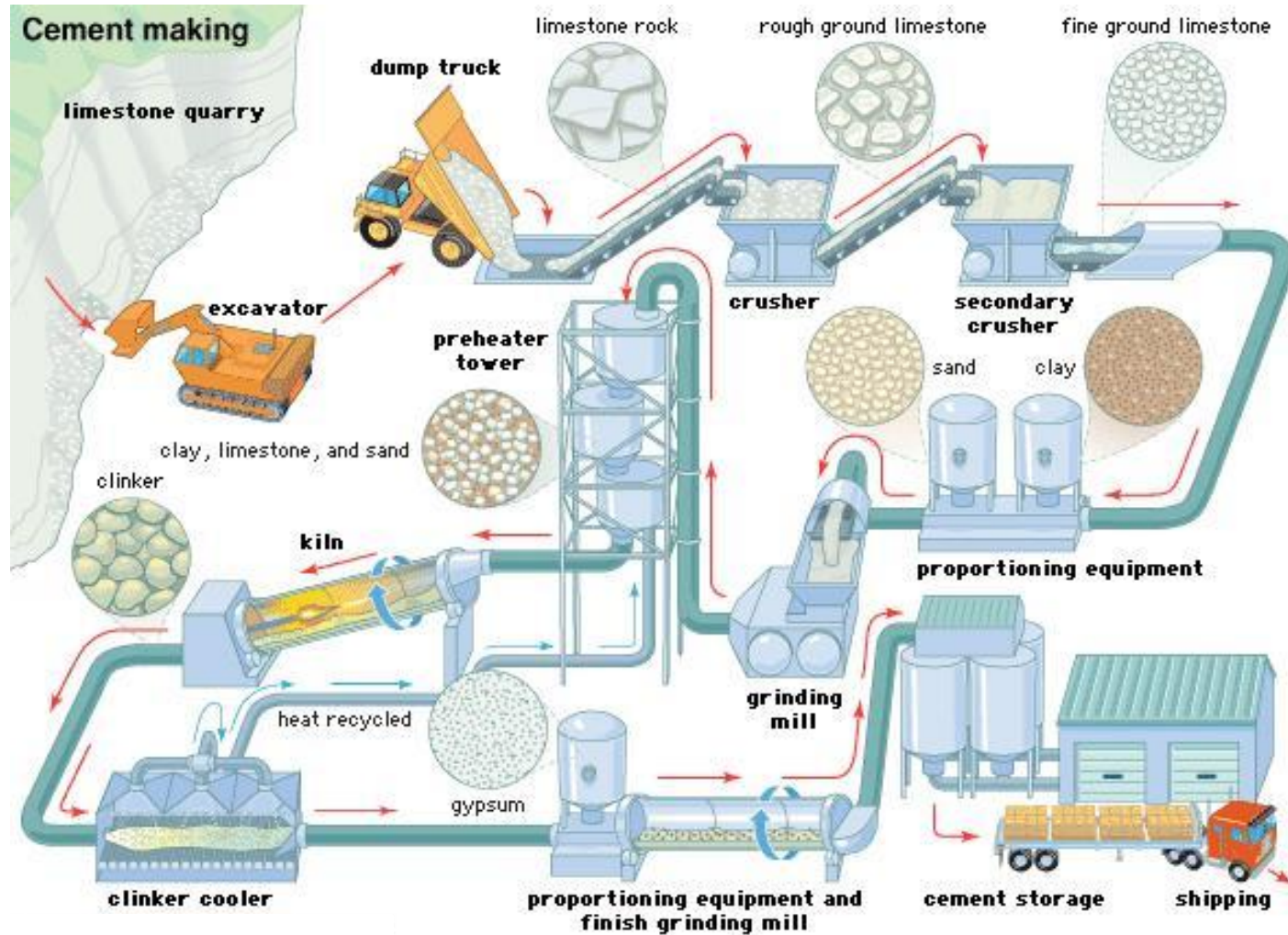

# Cement



# Settling Dust



# Heavy Dust



# Viruses

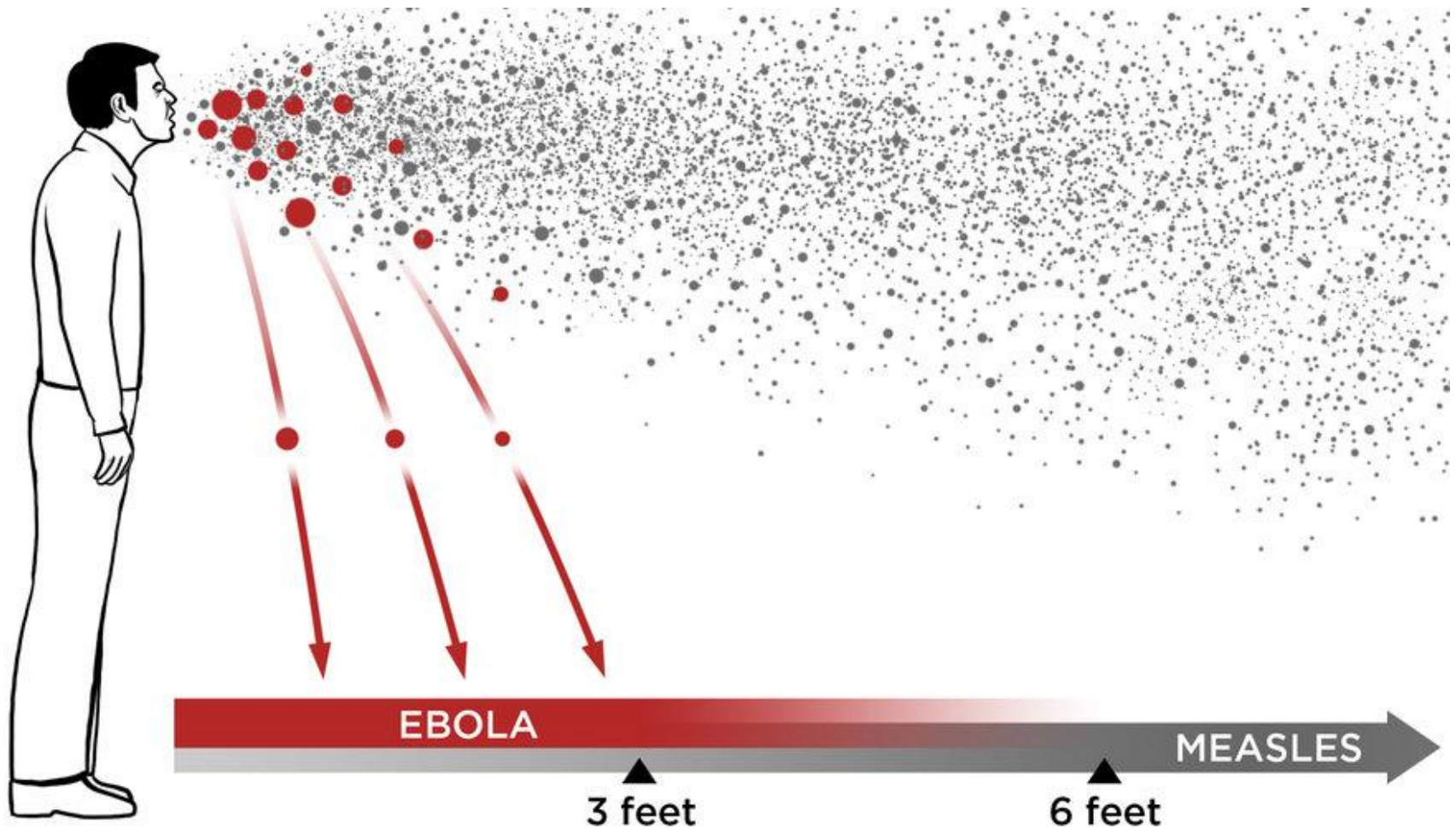

# Pollen



# Outline

- ▶ Concept of Active Sensing
- ▶ Understanding of Air Pollutants
- ▶ Parameter(s) of Dust in Air
- ▶ Measurement of Dust in Air

Carbon Monoxide  
Carbon Dioxide  
Nitrogen Oxide  
Sulphur Dioxide  
Volatile Organic Compounds  
**Particulate Matters**

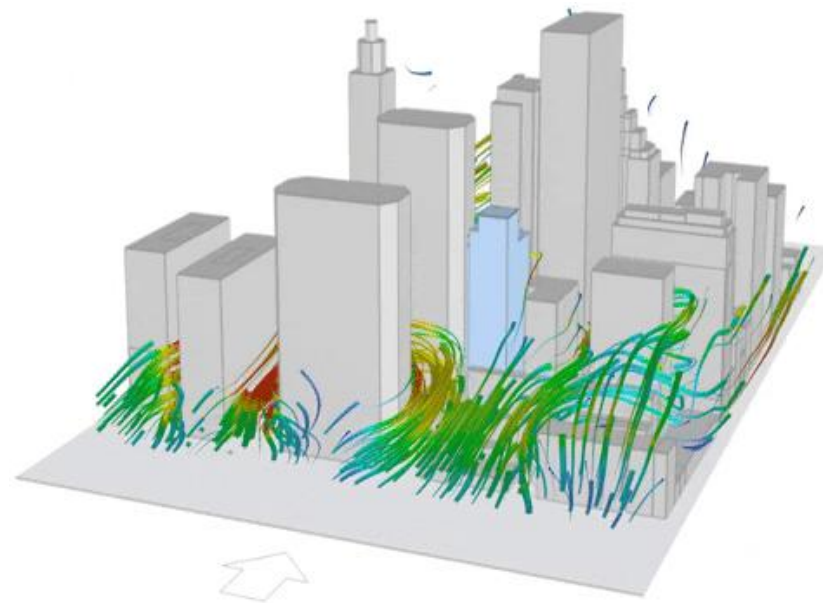
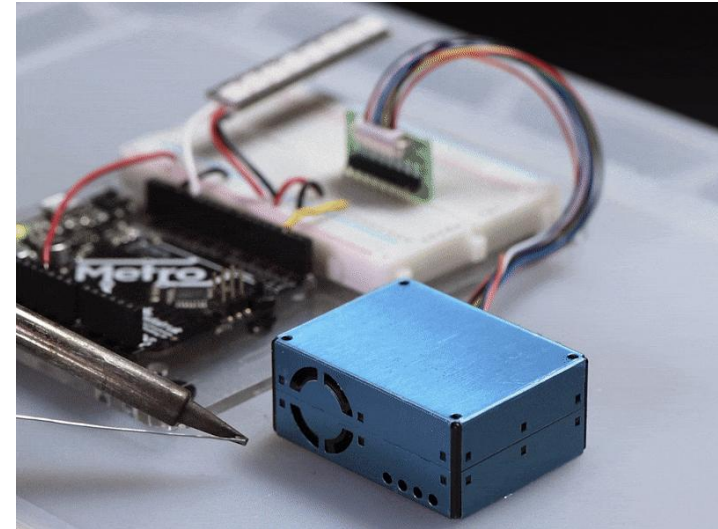

# Understanding Particulate Matters

- ▶ Particulate matter is a tiny solid which floats in air.

- ▶ Particulate matter has mass.

- ▶ Particulate matter has size.

- ▶ Particulate matter has velocity.

- ▶ Particulate matter could reflect light beams.

- ▶ Particulate matter has other properties and constraints.

HOW SMALL IS PM?

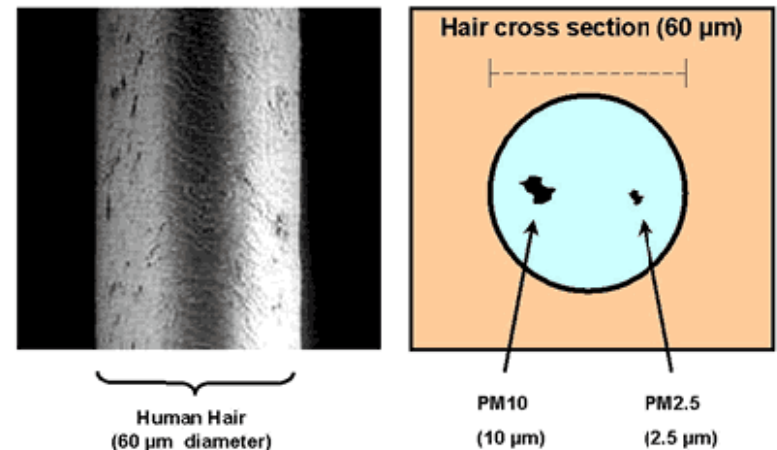

# Parameters of Particulate Matters

- ▶ Size: micro-meters
- ▶ Density: micro-gram / m<sup>3</sup>

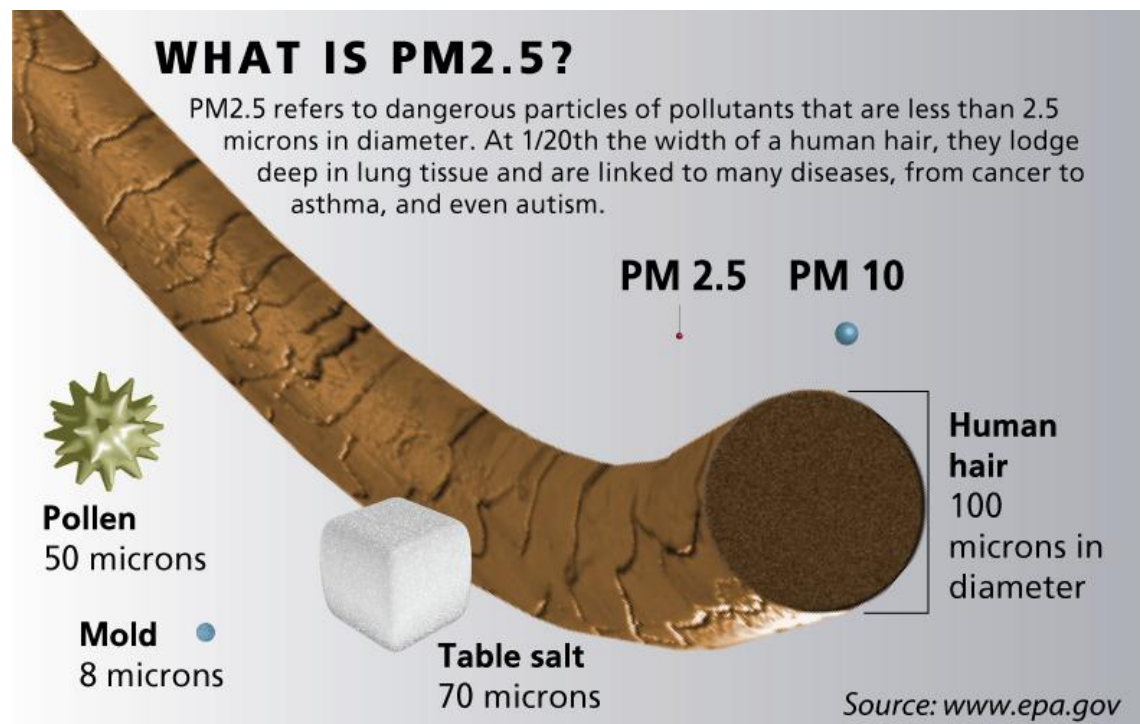

# Example of Monitoring PM<sub>2.5</sub> in Country ...

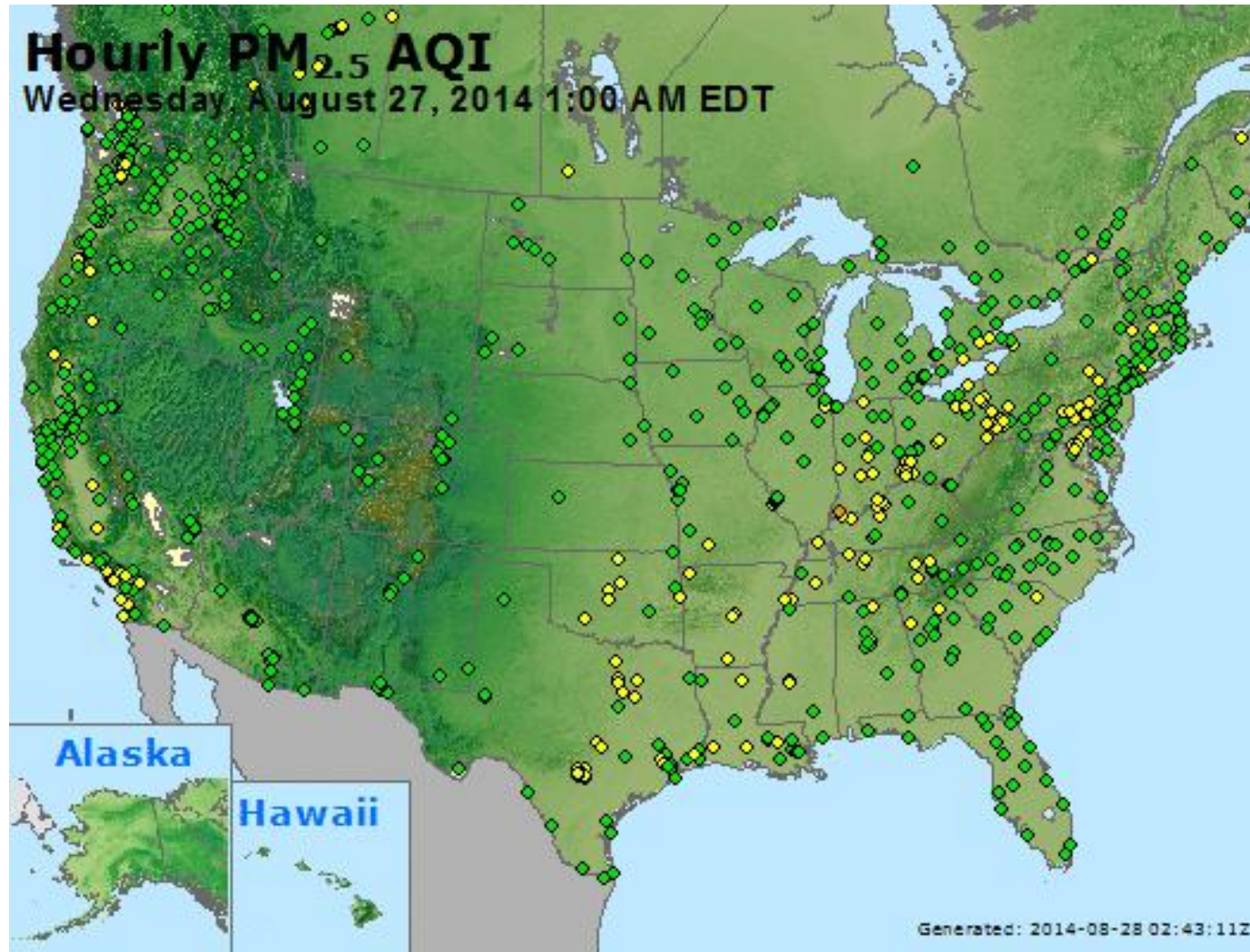

# Example of Monitoring PM<sub>2.5</sub> in Cities ...

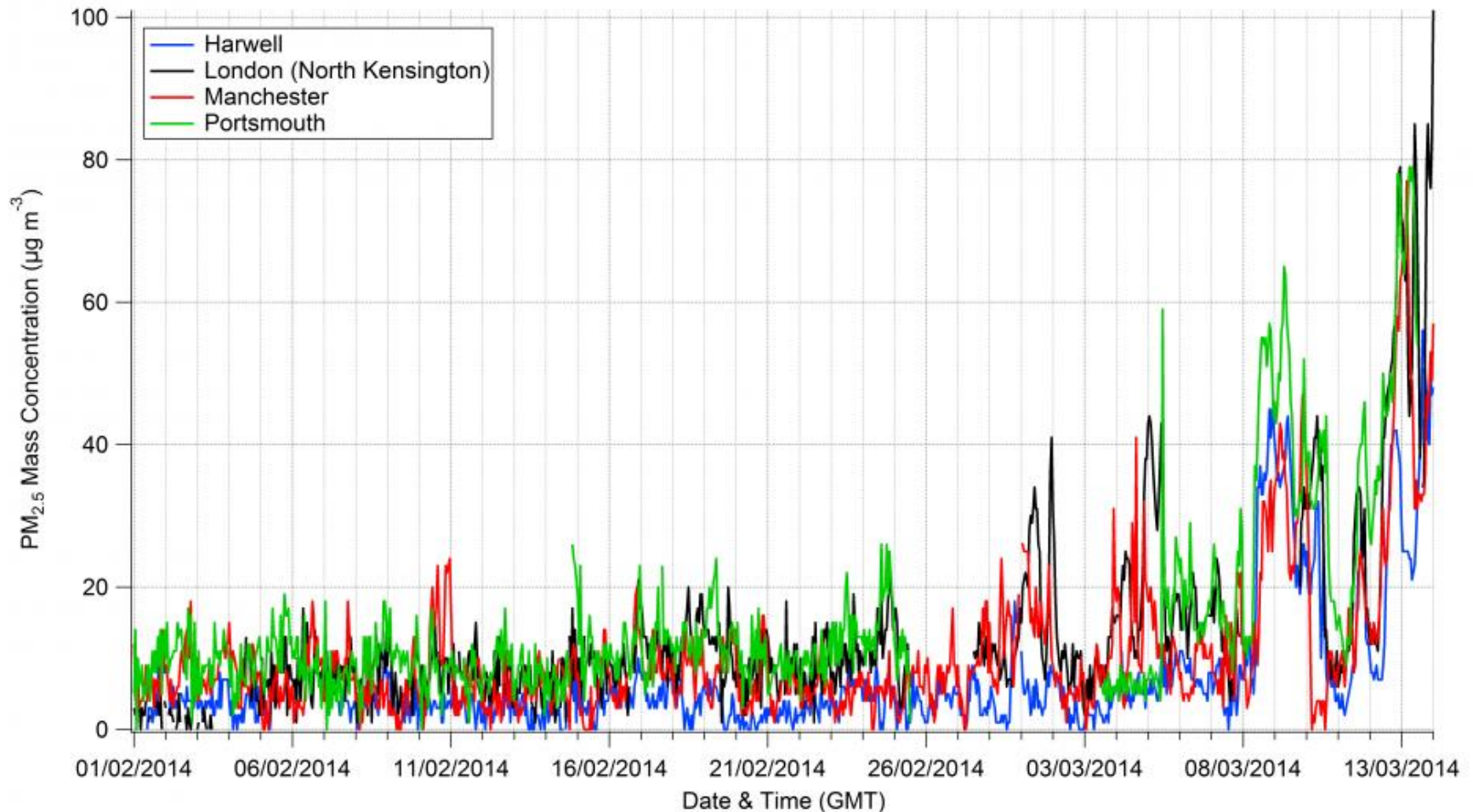

# Example of Monitoring PMs in Operations ...

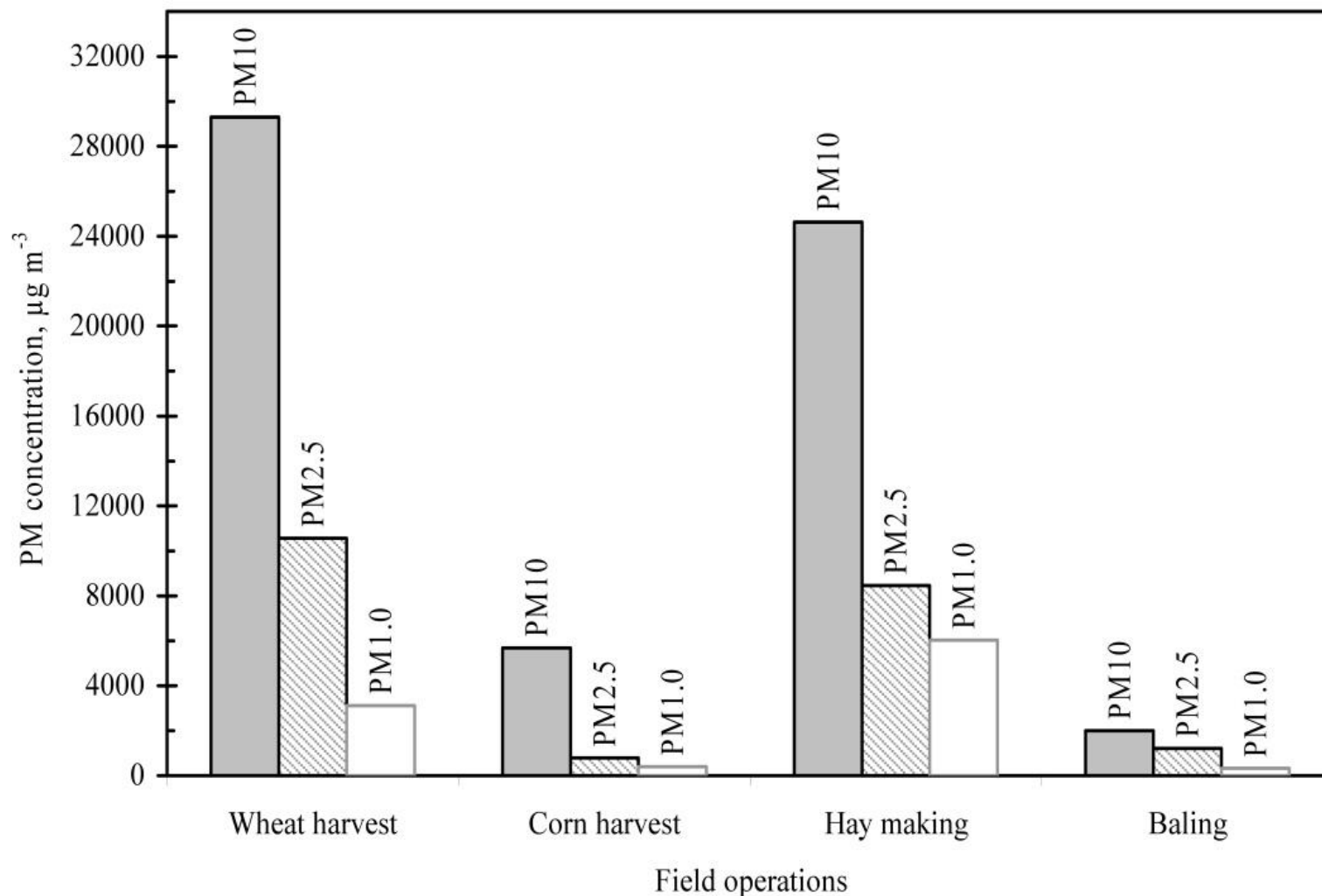

# Outline

- ▶ Concept of Active Sensing
- ▶ Understanding of Air Pollutants
- ▶ Parameter(s) of Dust in Air
- ▶ Measurement of Dust in Air

Carbon Monoxide  
Carbon Dioxide  
Nitrogen Oxide  
Sulphur Dioxide  
Volatile Organic Compounds  
**Particulate Matters**

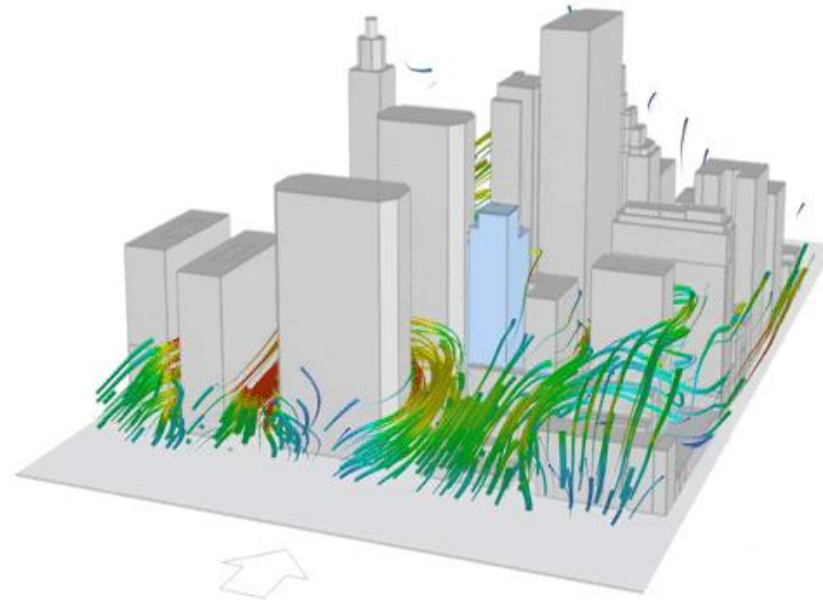
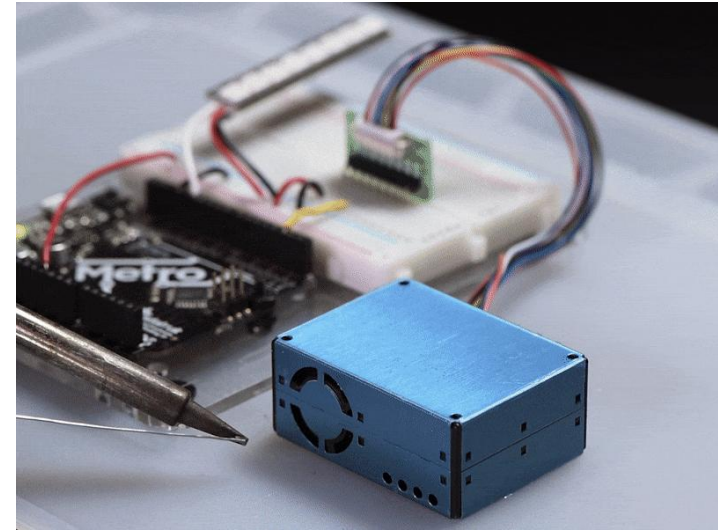

# Pollution Effects on Health ...

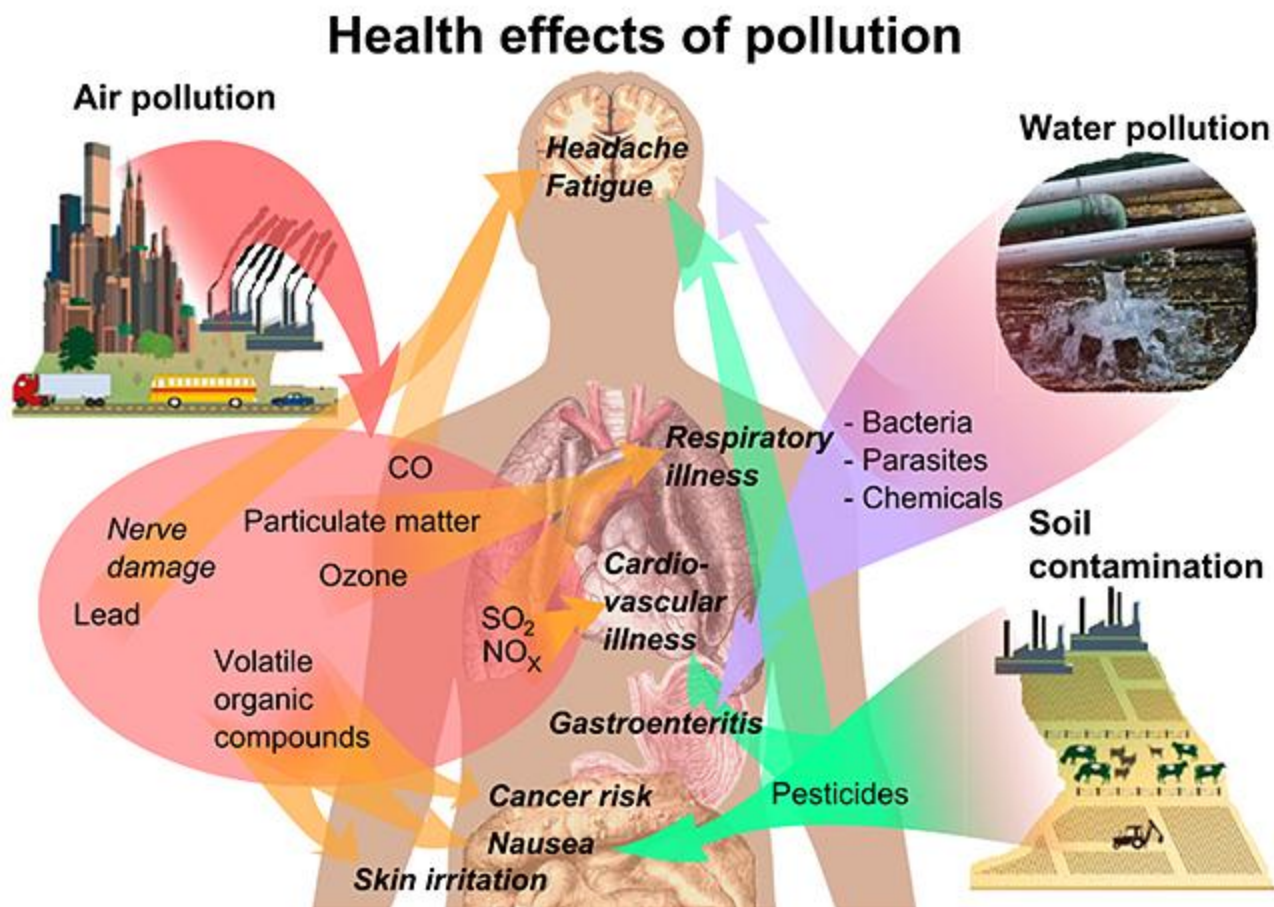

# Pollution Effects on Health ...

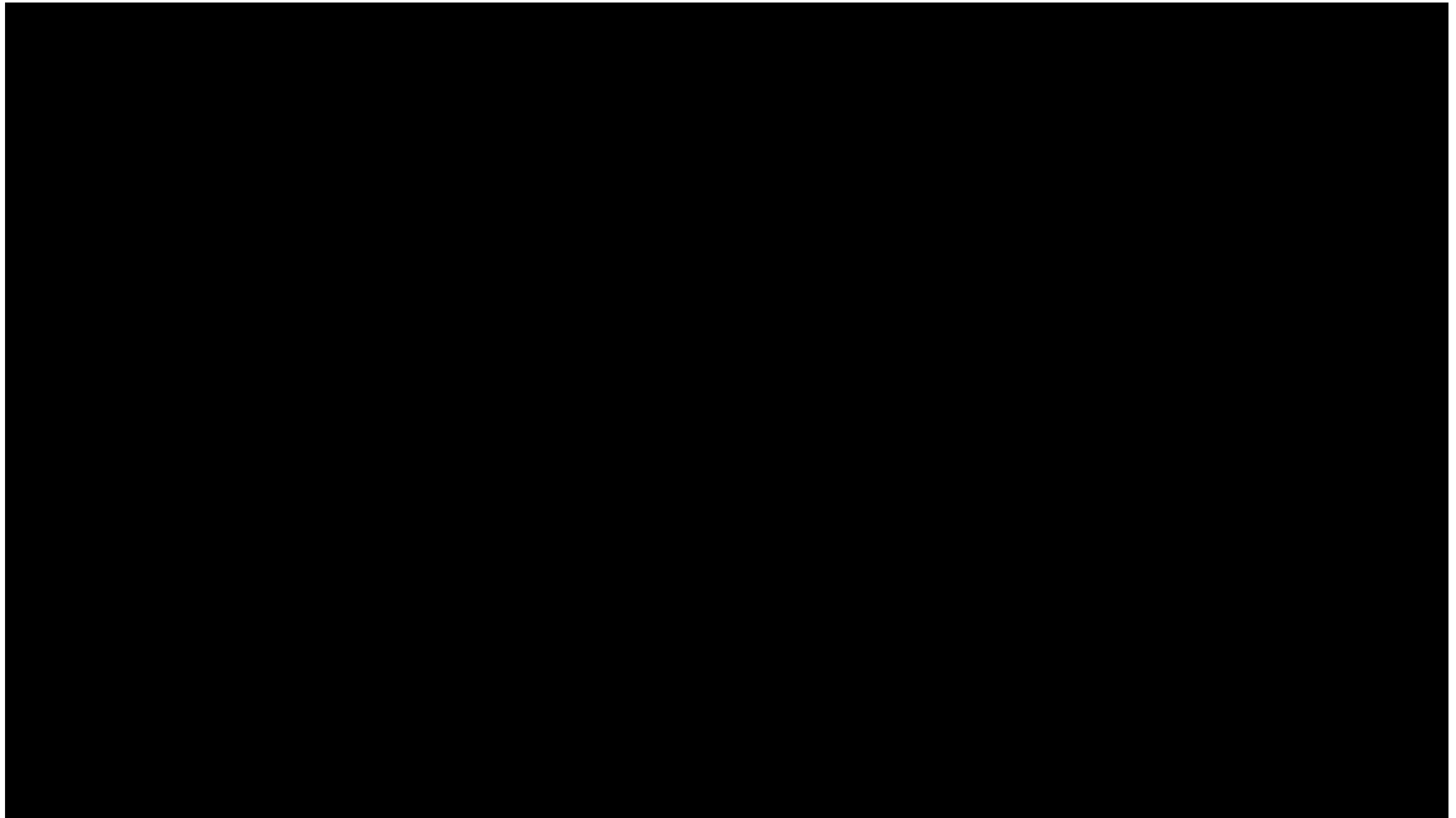

# More Details ...

## Unseen harm

Smoke particles are so fine they can slip past macrophages, immune cells inside the alveoli that destroy foreign particles. We cannot see the tiny particles that are being embedded in our lungs.

Substance	Size	
	Micrometers	Inch
90% of wood smoke particles	1 micron	0.00004
Red blood cell	8 microns	0.0003
Human hair	70 microns	0.003

**Smoke** comes from a mixture of gases and fine particles produced when wood and organic matter burn.

**Particulates** can damage the alveoli which allow oxygen to be carried into the bloodstream. This makes it harder to get sufficient oxygen to the body, causing the heart to work harder to compensate.

**Particulates** may cause more deaths in people with heart disease.

**Smoke effects** range from eye and respiratory tract irritation to reduced lung function, bronchitis and asthma exacerbation, coughing and excess mucus.

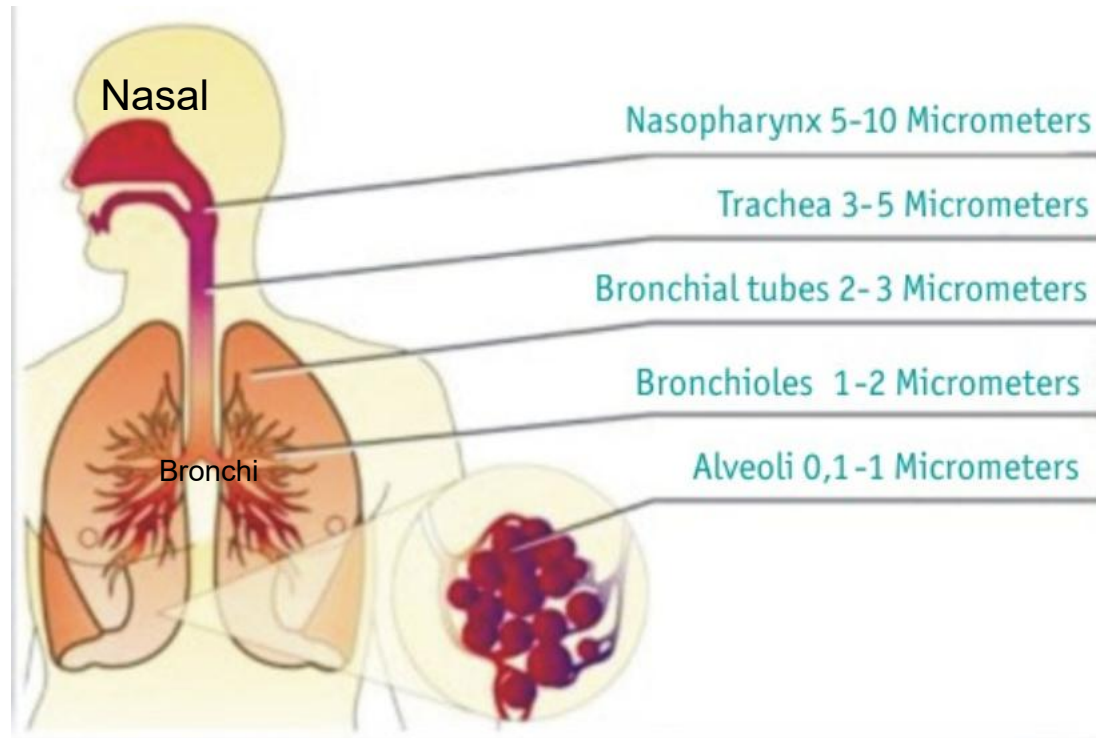
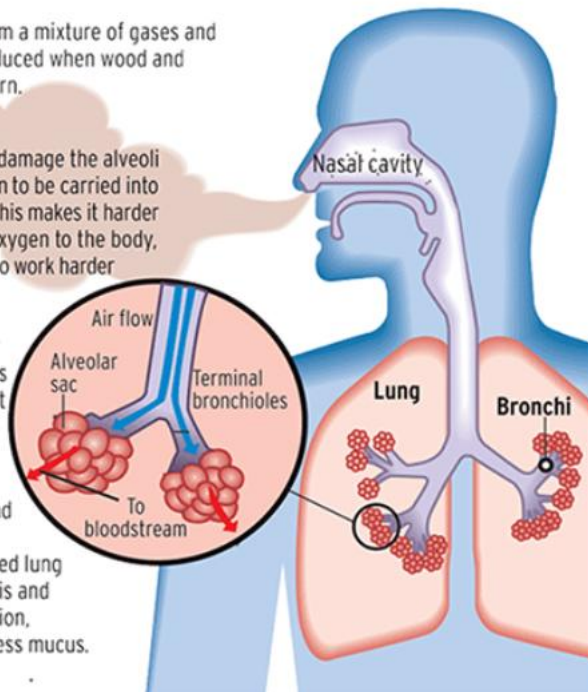

# Principle of Measurement

► The common principle is to convert density of particulate matters into light intensity which could be further converted into time function of voltage. The time function of voltage could be automatically measured. The implementation of this principle involves:

- Step 1: Filtering of Inflow Air under Measurement.
- Step 2: Conversion of Density of Particulate Matters into Light Intensity.
- Step 3: Conversion of Light Intensity into Time Function of Voltage.
- Step 4: Post-processing of Voltage Signals (i.e. counting of peaks).

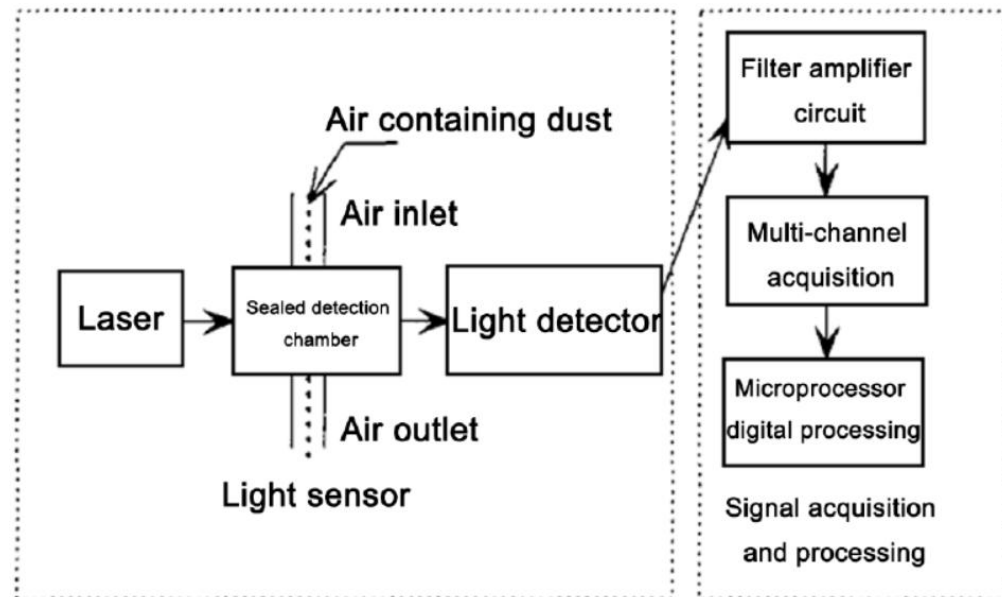
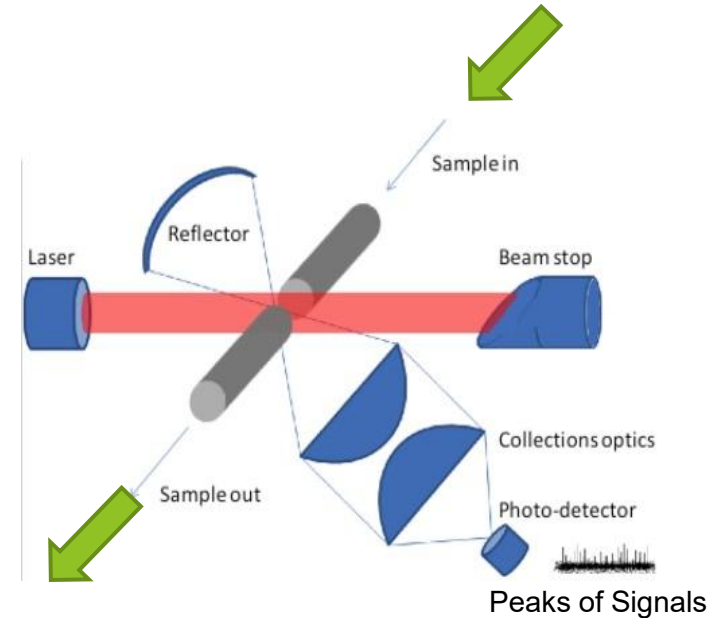

# How to apply the principle to design digital measurement and sensing systems for dust in air?

- ▶ Inflow air is passing through filtering area and then enters the space between light-emitter and light detector. Density of particulate matters is converted into intensity of reflected lights, which is further converted into voltage. Voltage is measured by digital voltmeter (e.g. microcontrollers).

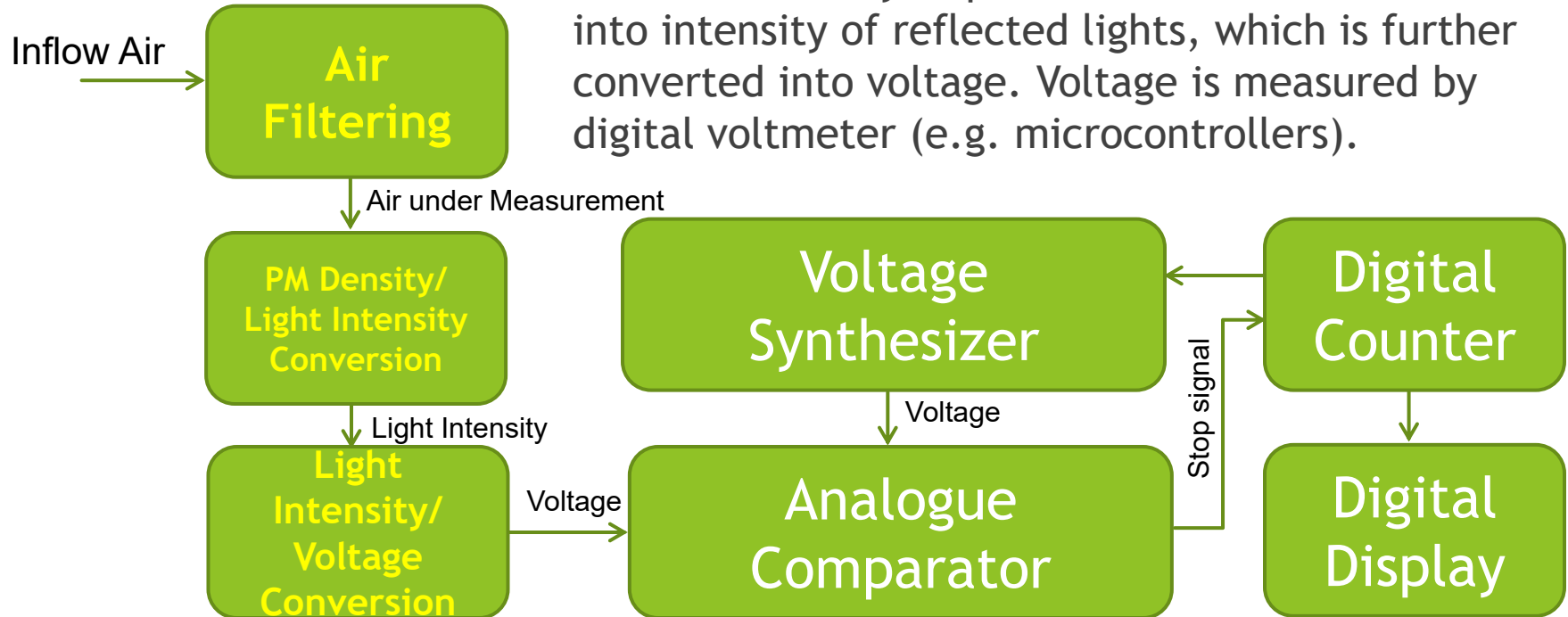

All microcontrollers are programmable digital sensors of voltage!

# How to filter out larger particulate matters from inflow air?

- L-shape pathway
- U-shape pathway

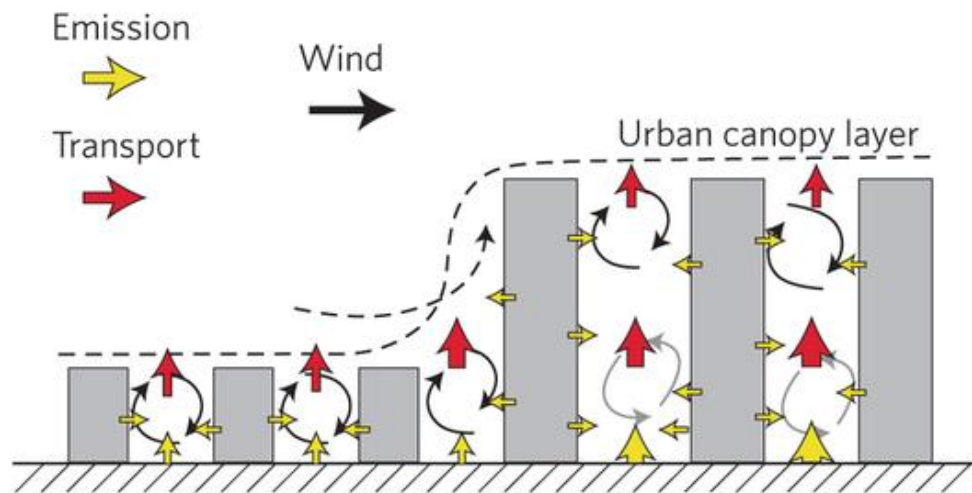
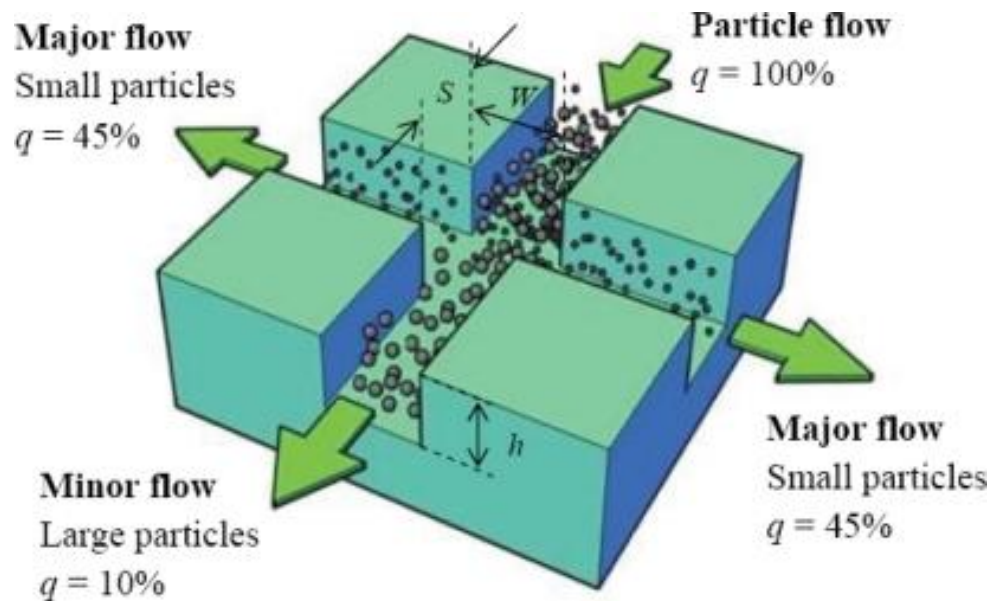
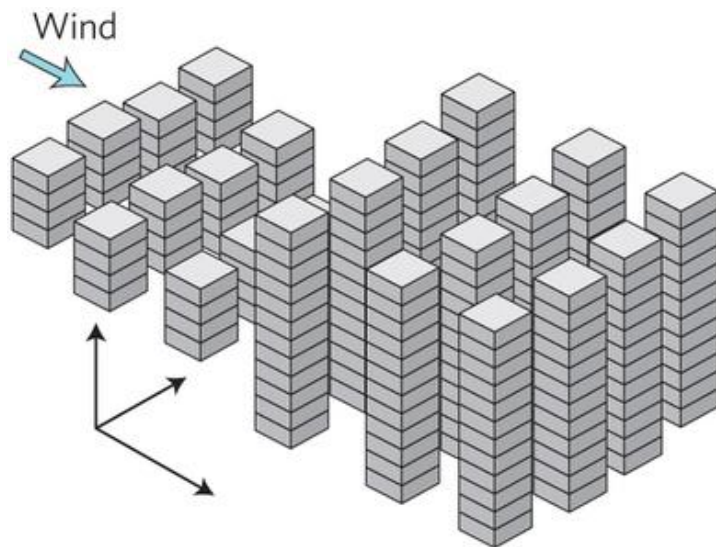

# How to filter out water vapors from inflow air?

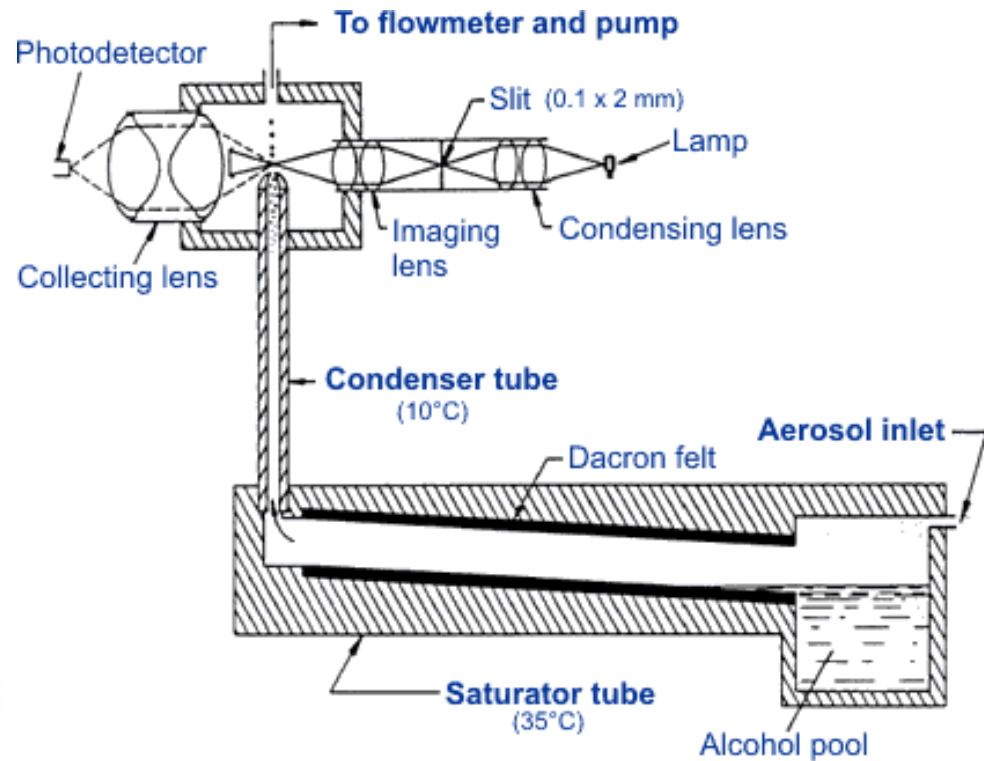
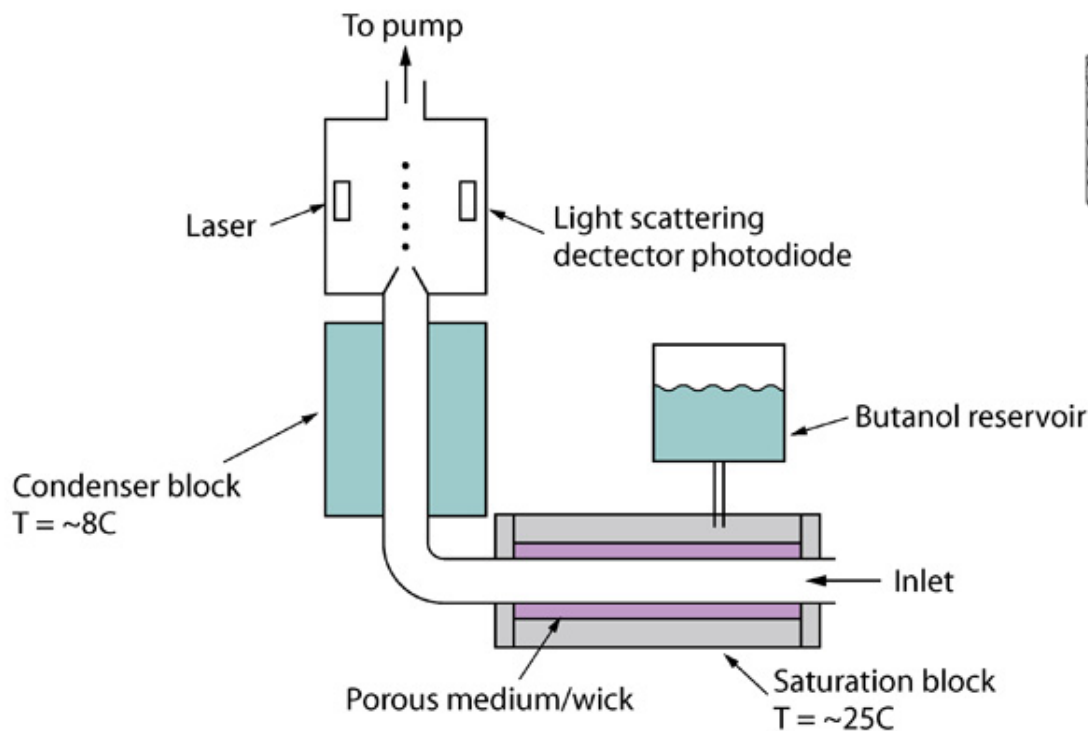

# How to convert density of particulate matters in air into intensity of light?

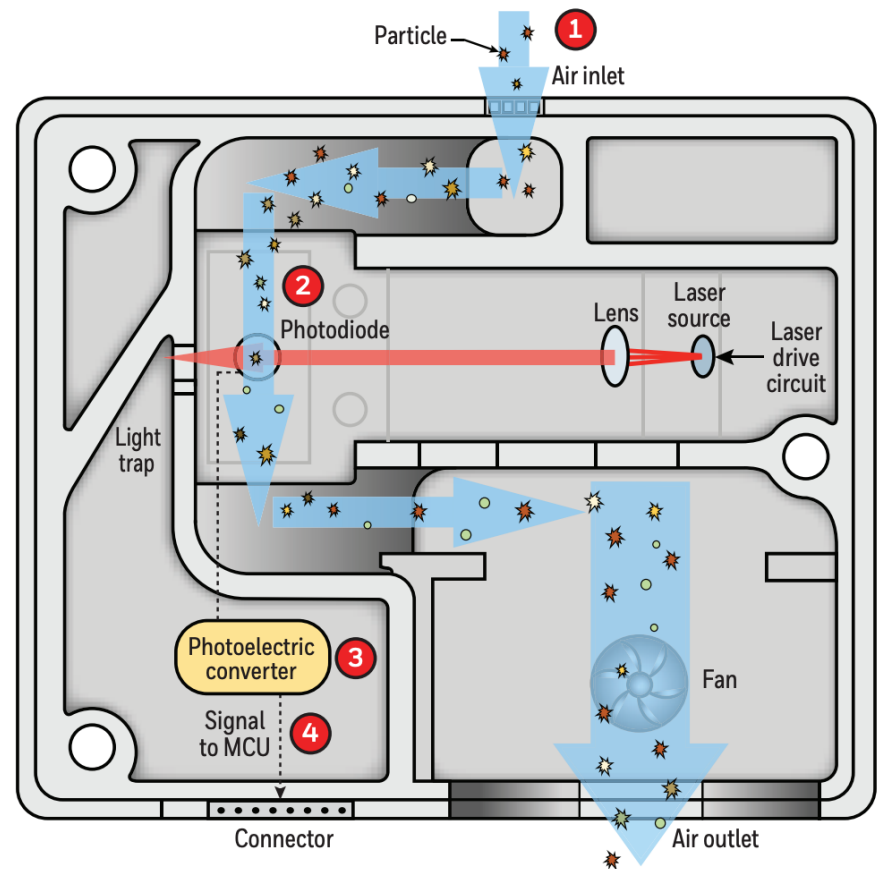
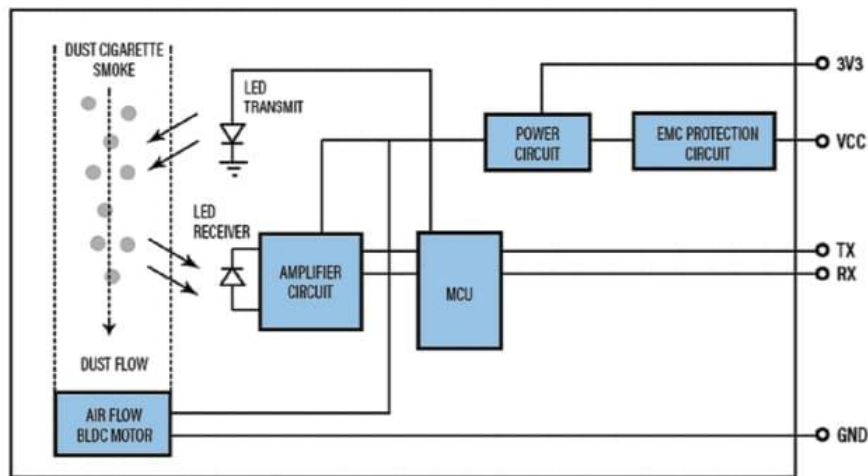
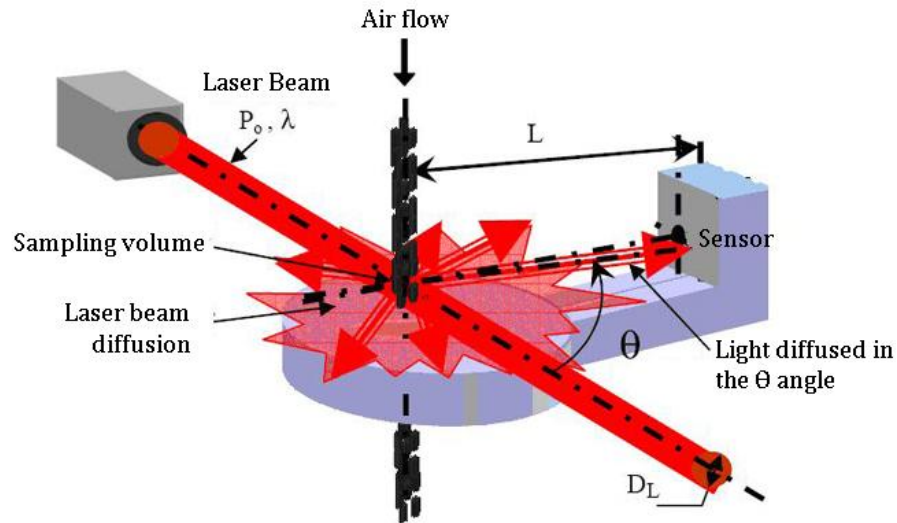

# More examples ...

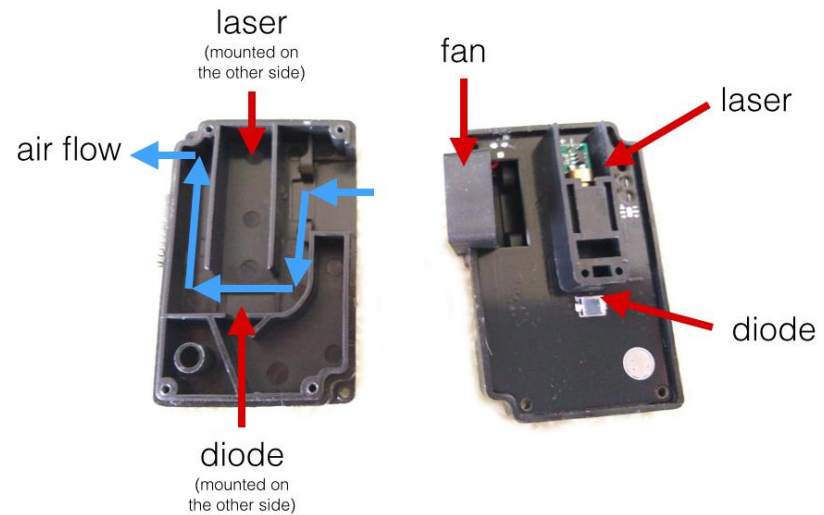
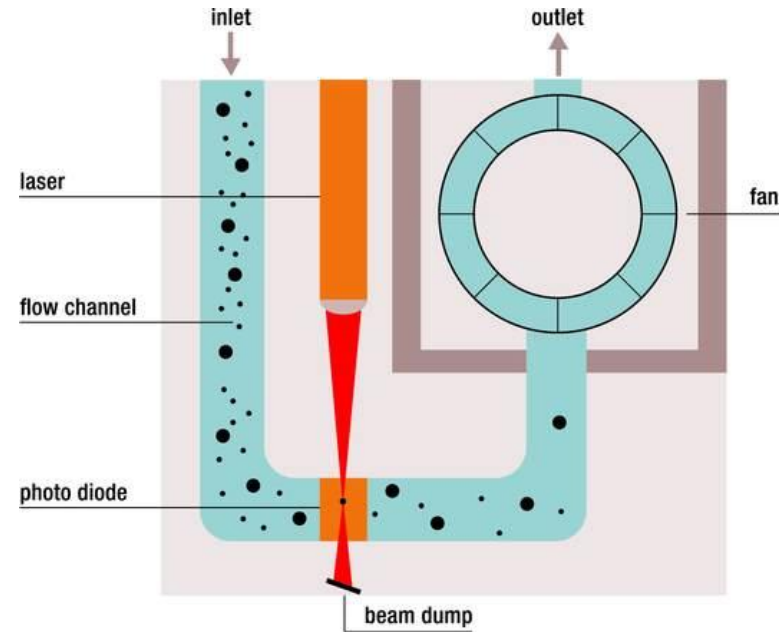
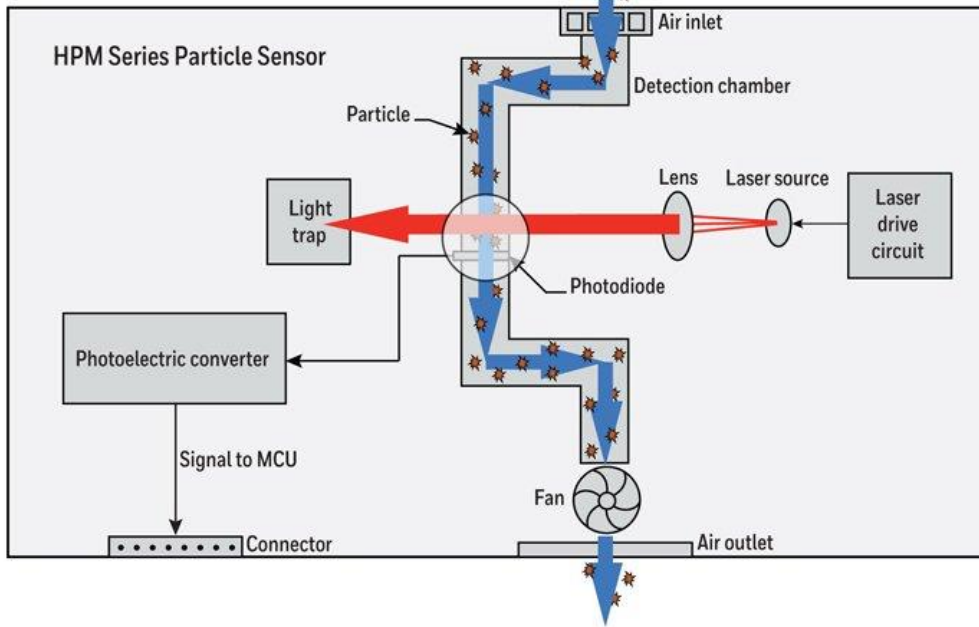

# Example of Intensity of Echo Signals ...

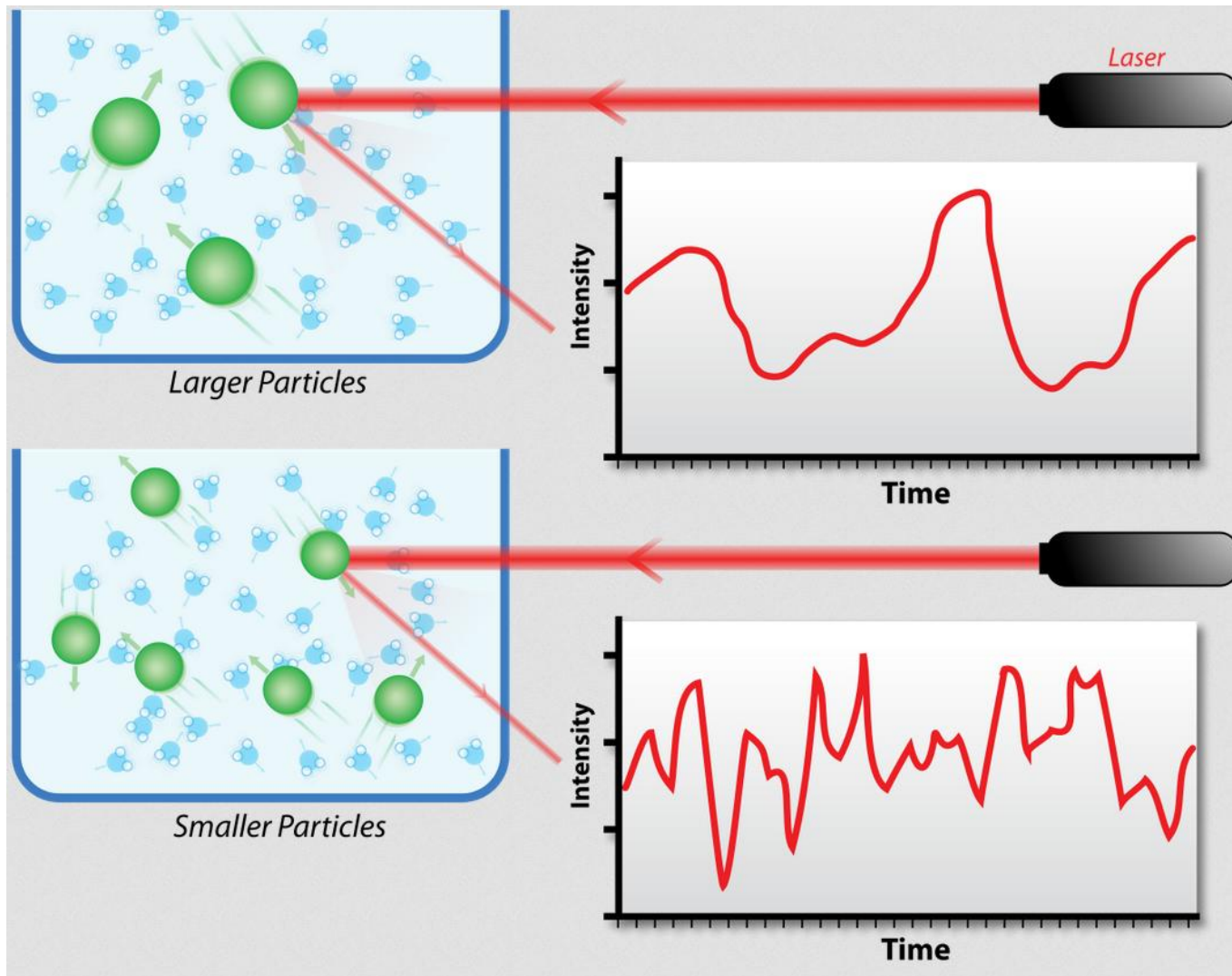

# How to convert light intensity into time signal of voltage?

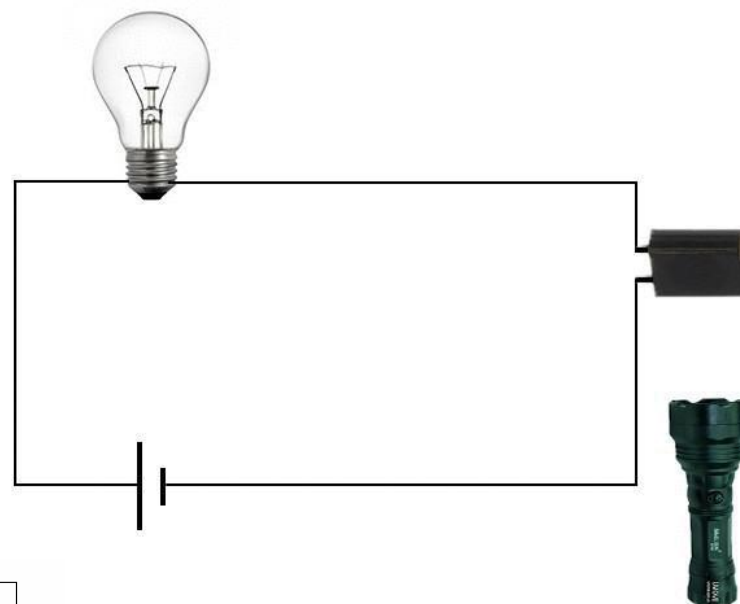

MakeAGIF.com

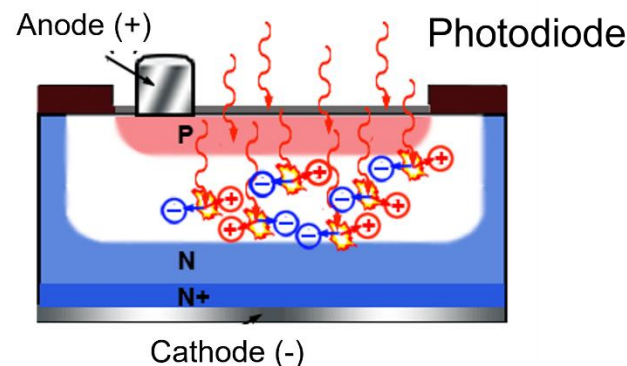
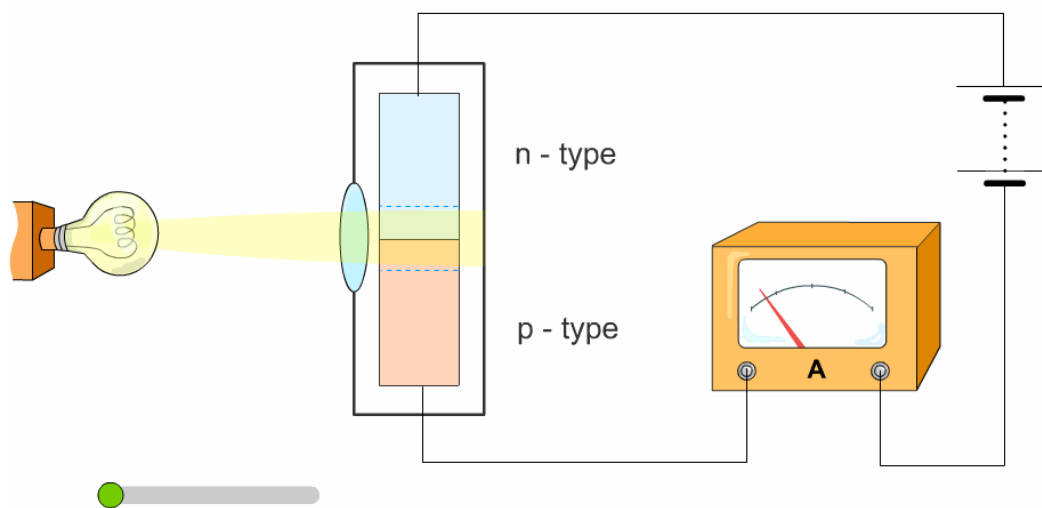

# A Person to Remember: Albert Einstein

- ▶ He has discovered the photoelectric effect which is the emission of electrons from a material caused by electromagnetic radiation such as ultraviolet light. Electrons emitted in this manner are called photoelectrons.

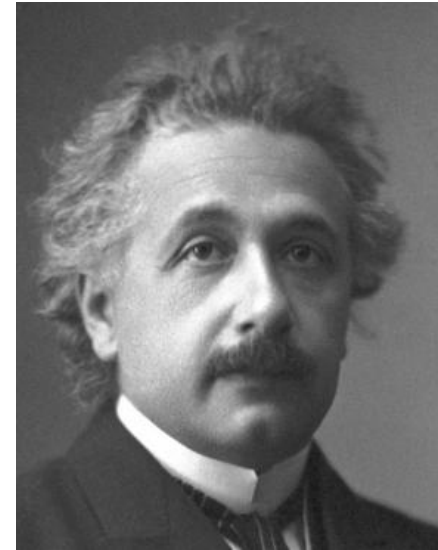

**Nobel Prize in Physics 1921**

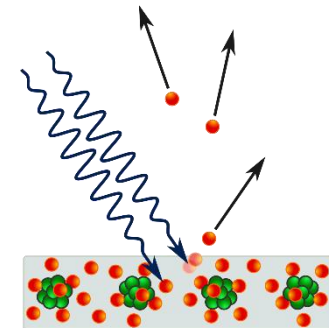
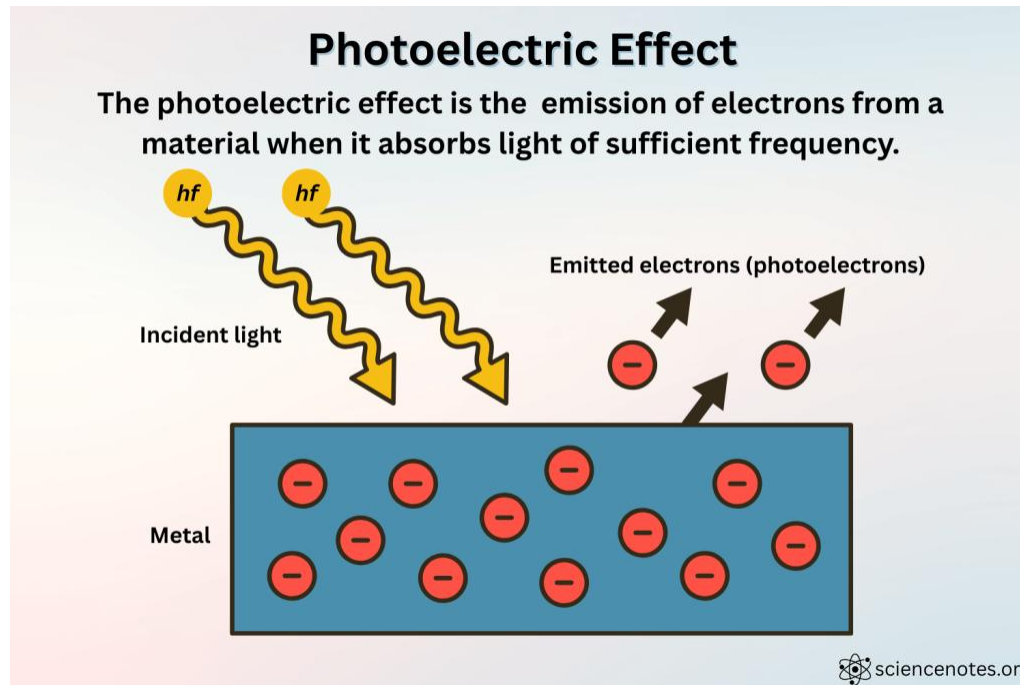

# How to convert light intensity into time signal of voltage?

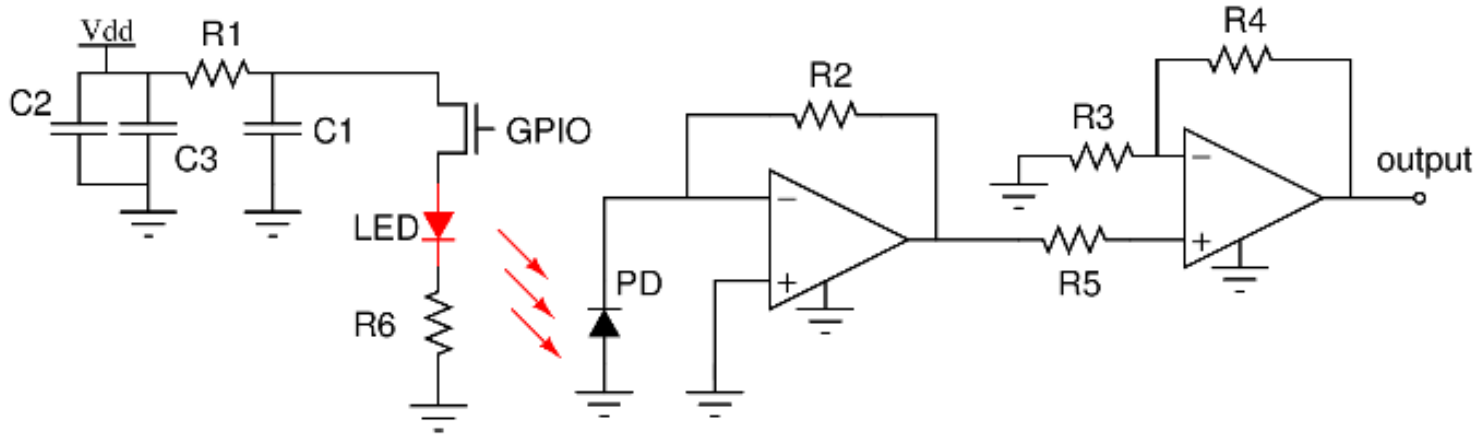
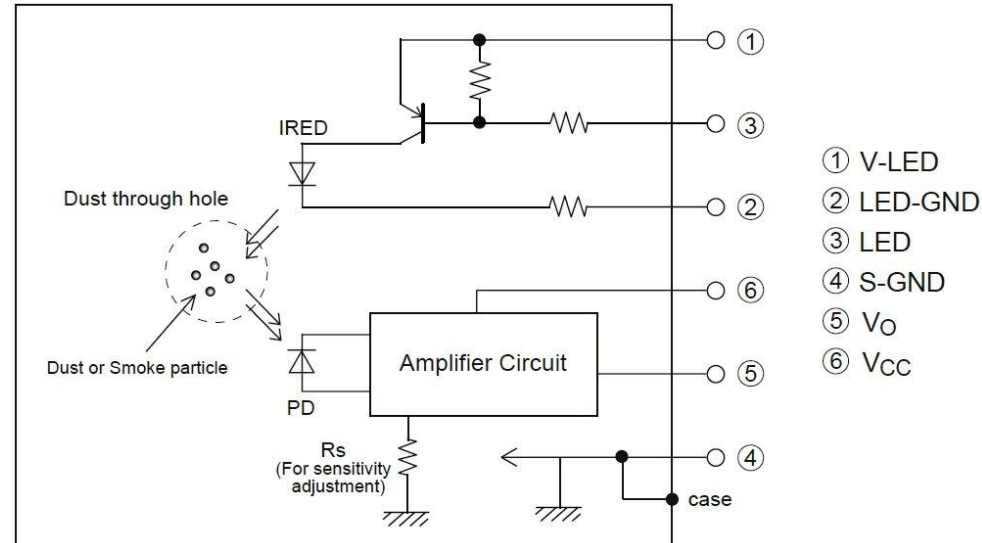
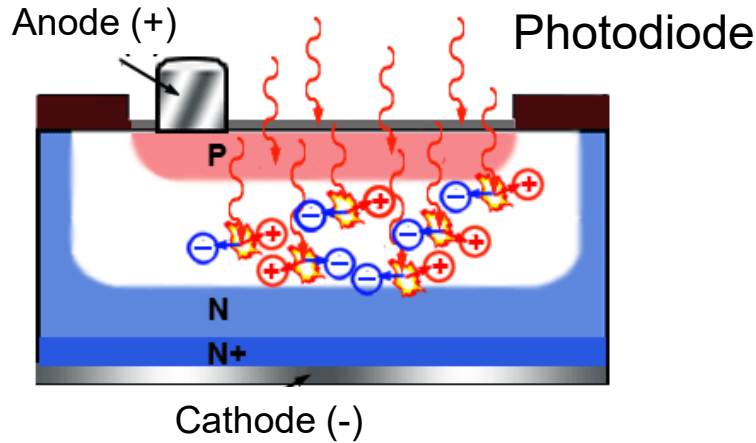

# More example ...

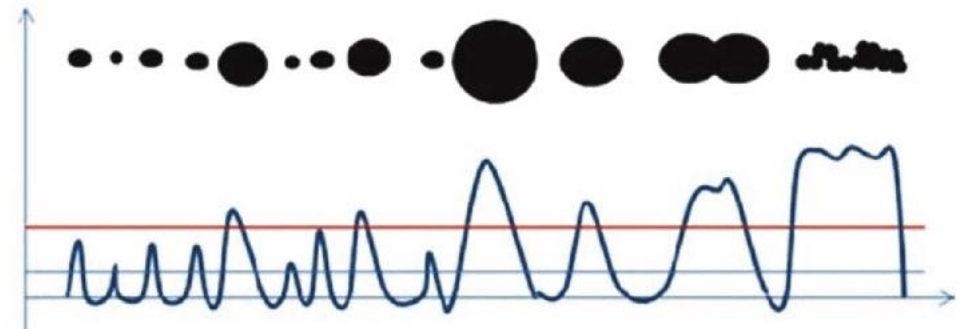
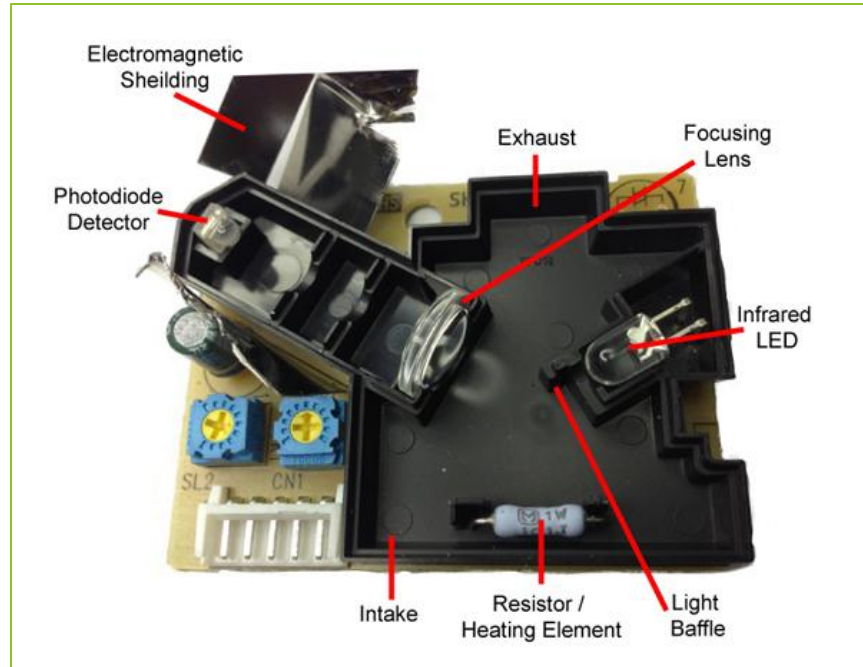
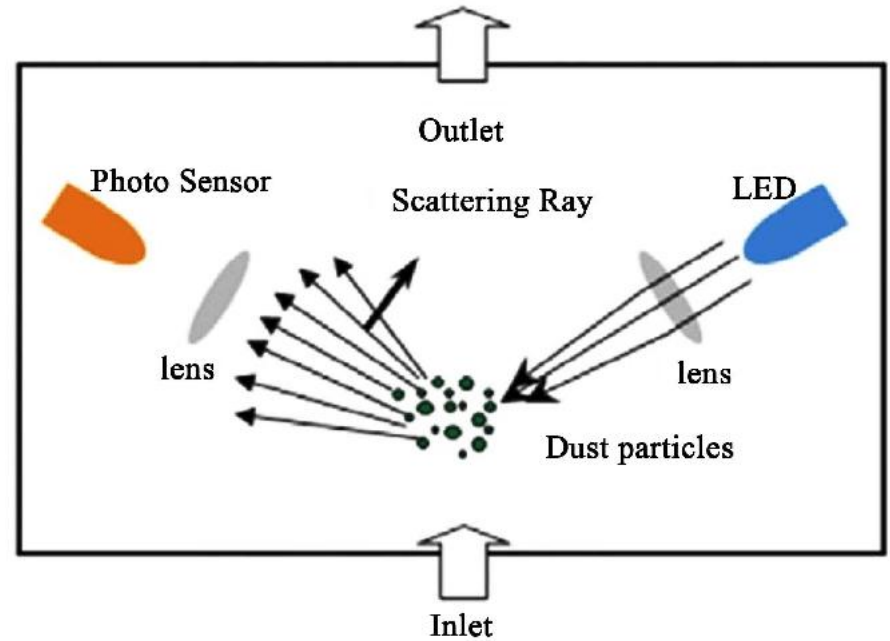
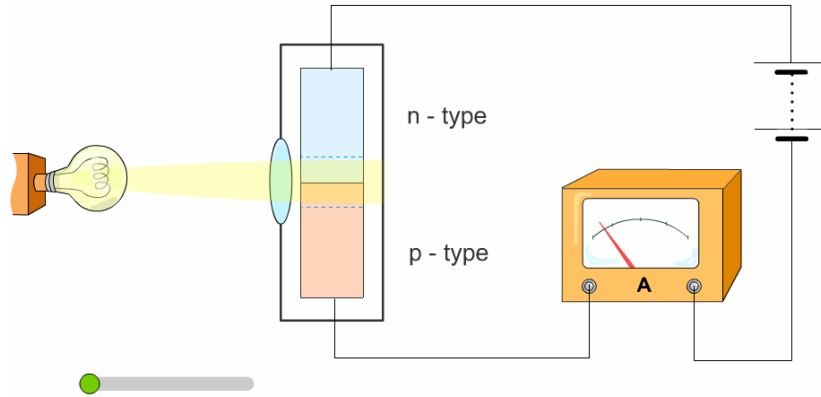

# Example of Voltage Signals

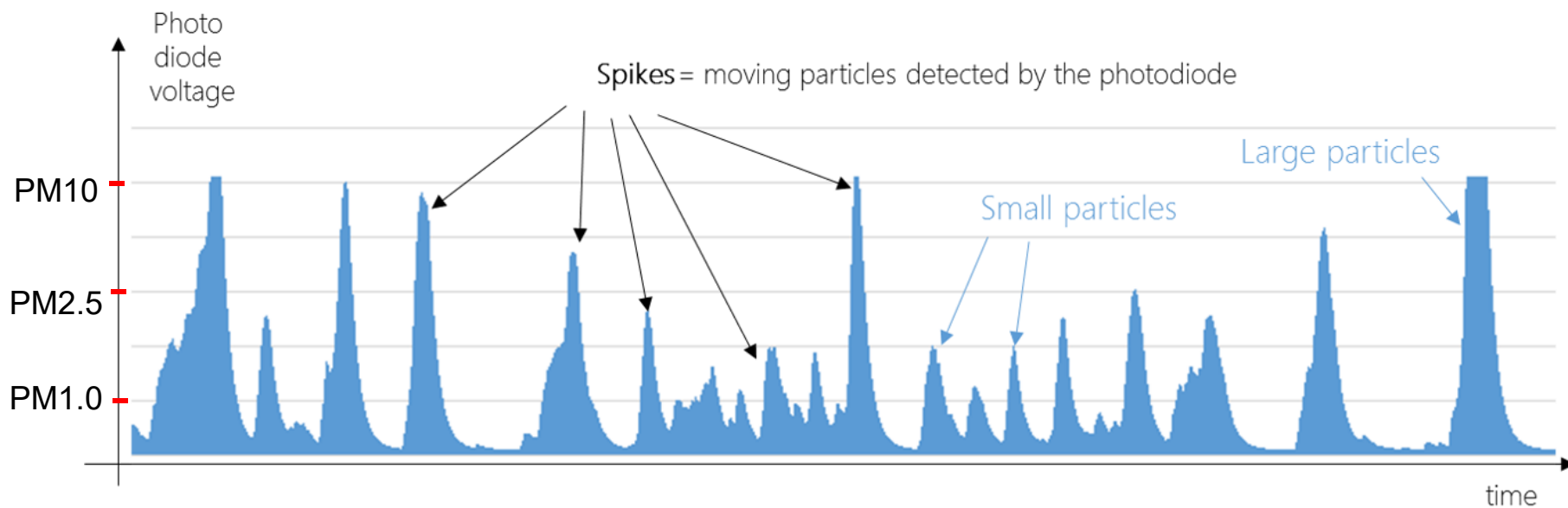
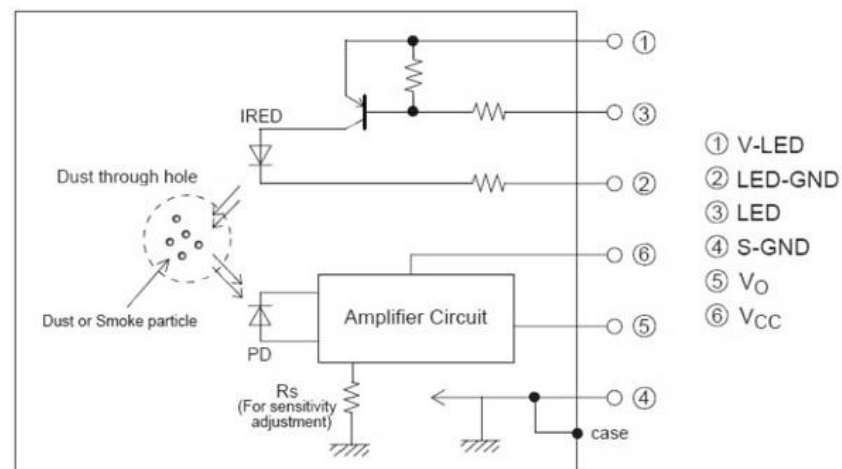

# Example of Implementation ...

## PM2.5 sensor

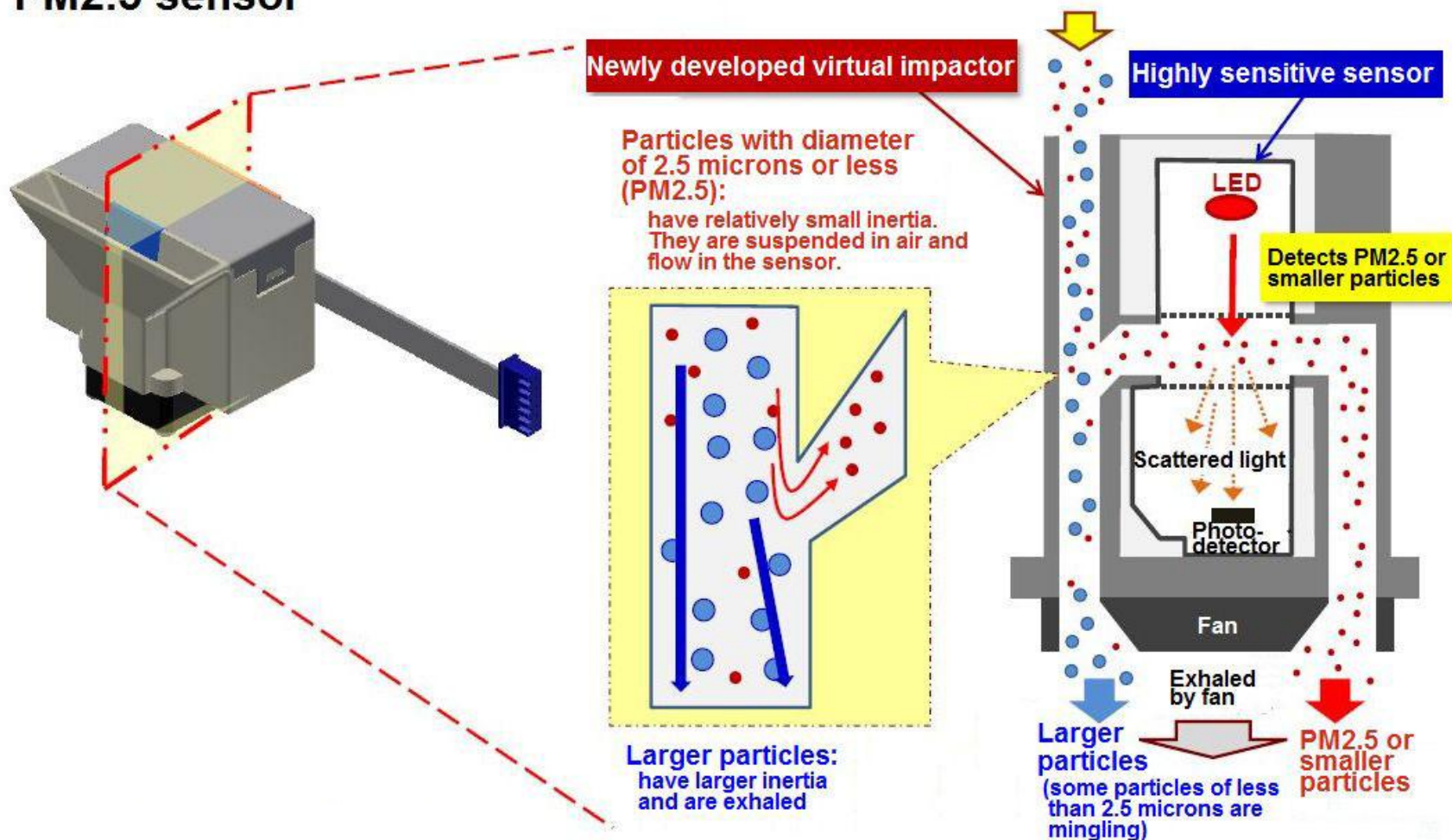

# Example of Prototype ...

**Laser dust sensor**

PM1.0 PM2.5 PM10

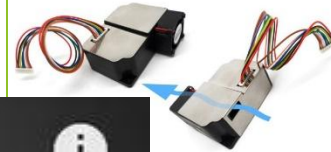

**Honeywell HPM Series**  
Particle Sensors

Search for this component and others at DigiKey.com

0:06 / 0:59

Digi-Key  
ELECTRONICS

## Example of Prototype (continued ) ...



# Example of Results ...

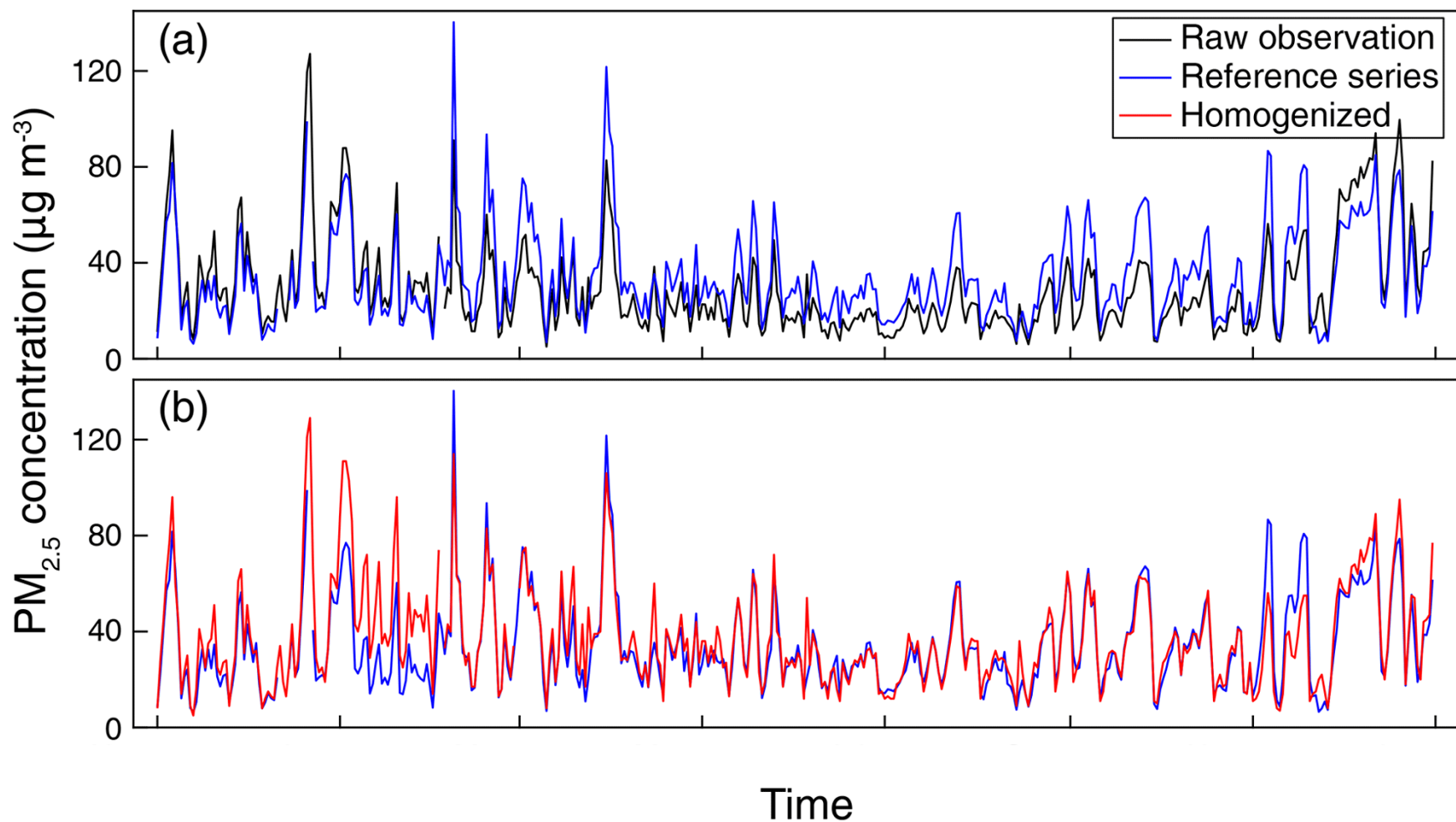

# Remember to Do Calibration

## ► Curve fitting for calibration:

- $Y_i$  is produced by  $X_i$
- $Z_i$  is computed from  $Y_i$
- $Z_i$  must be equal to  $X_i$

Calibrated Values  $Z_i$

Measured Values  $Y_i$

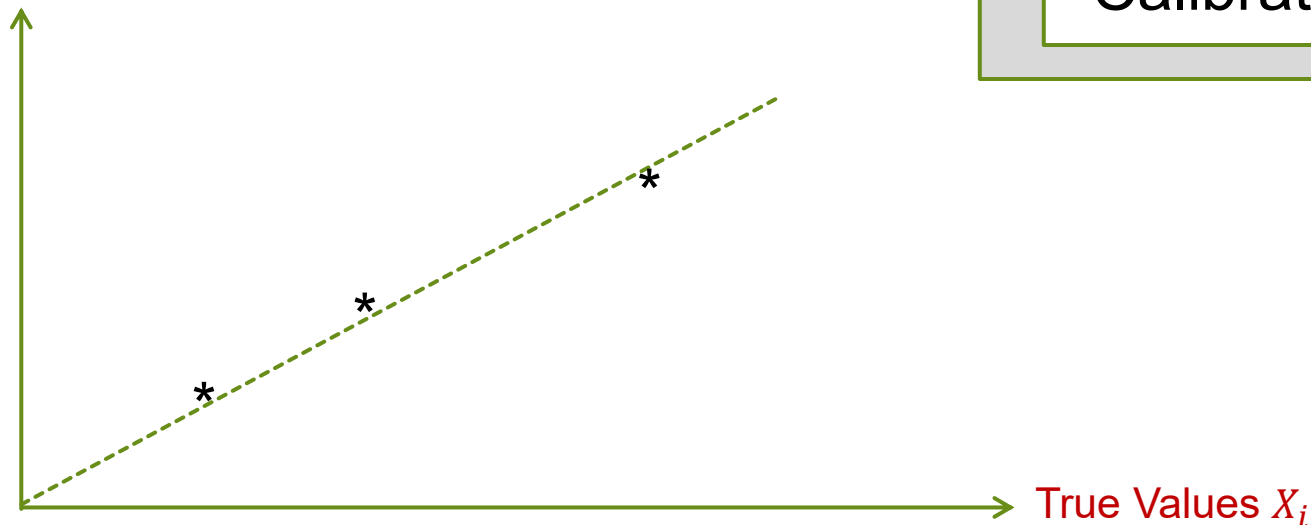

## How to prepare calibration samples?

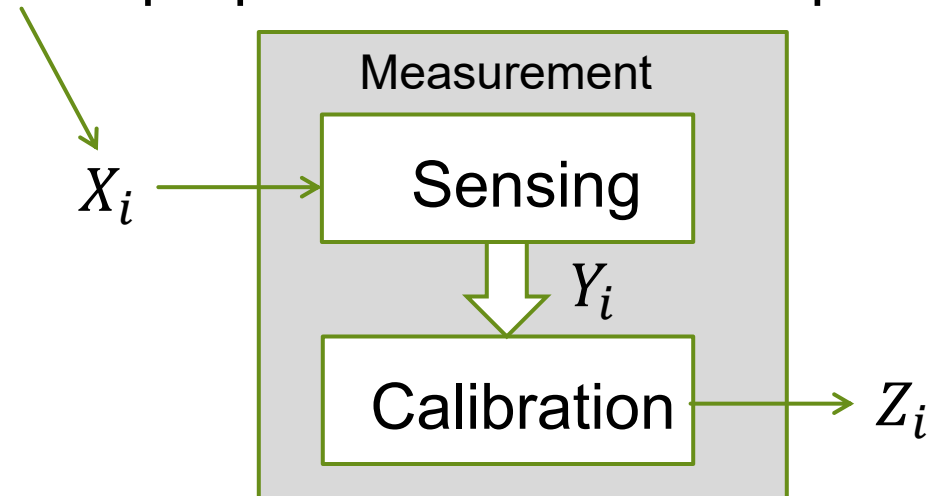

# Example of Calibration Setup ..

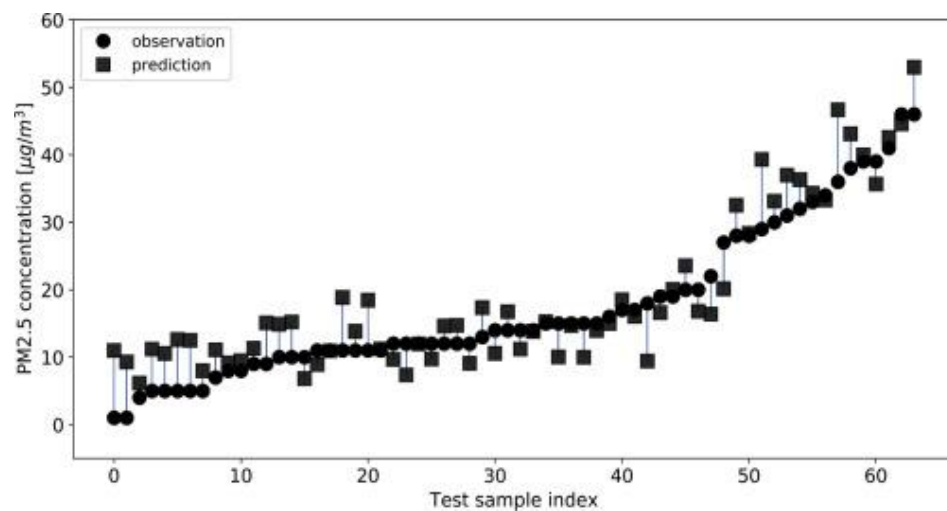
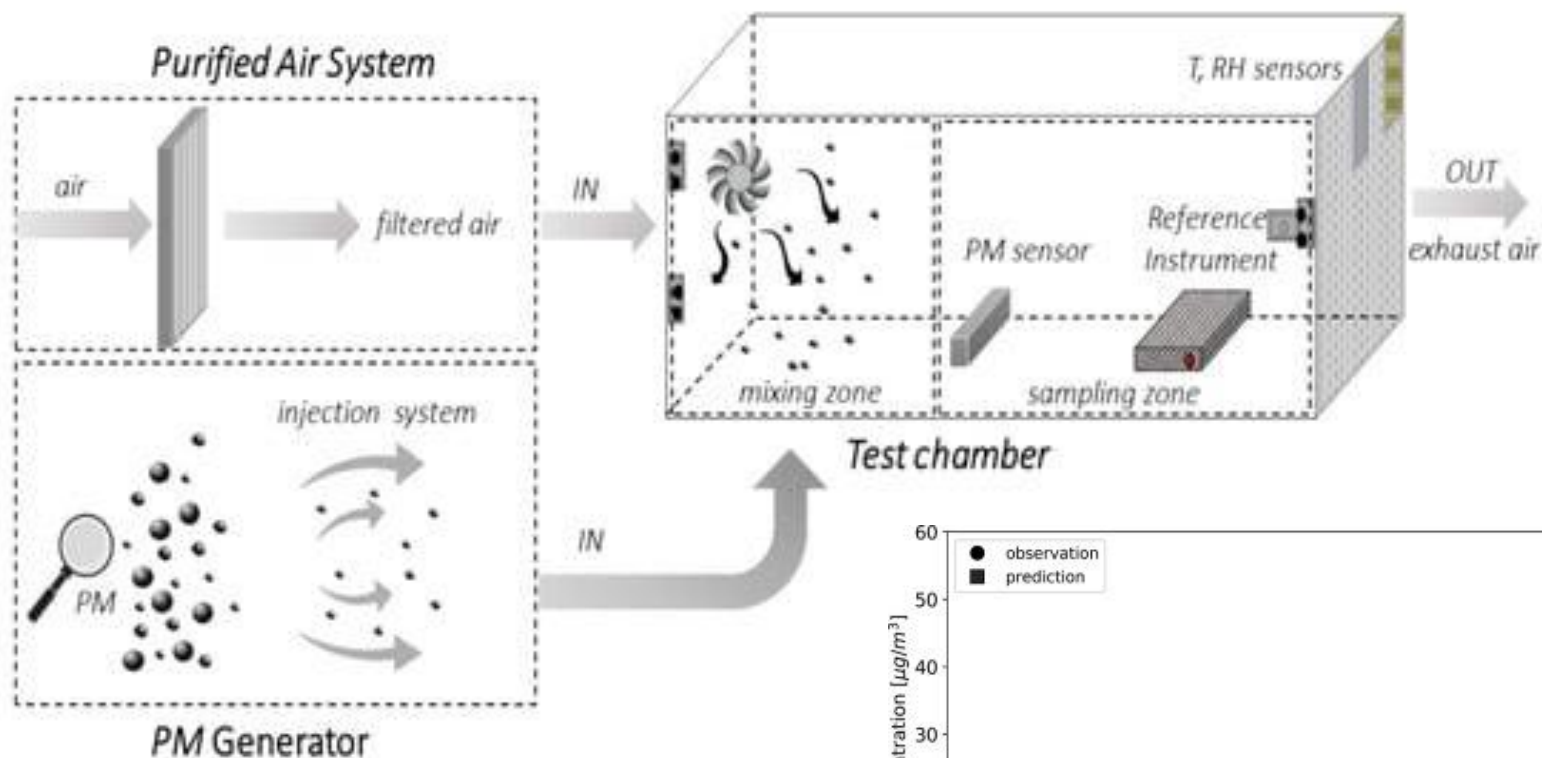

# More example of Calibration Setup ...

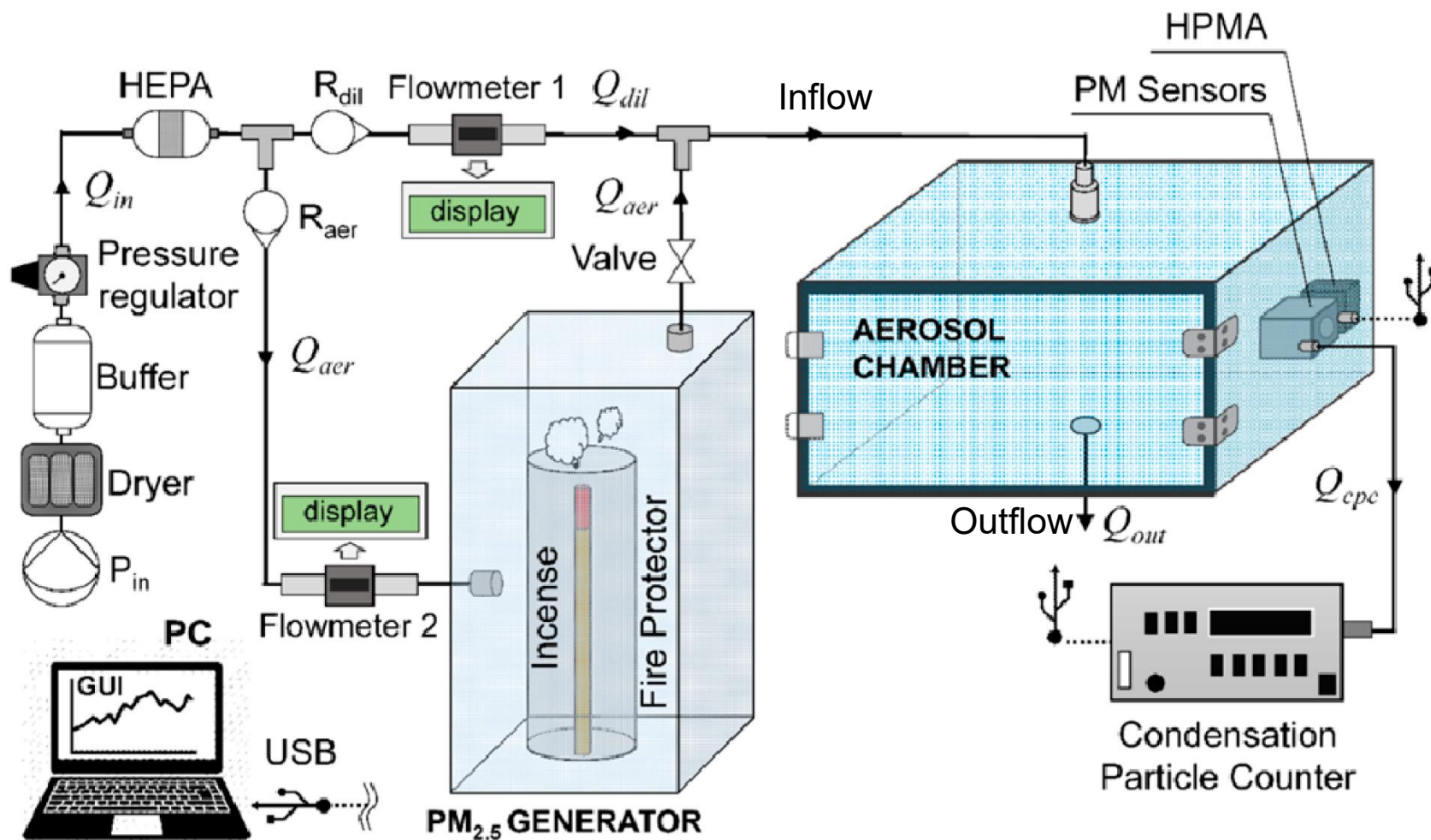

# Example of Calibration Results ...

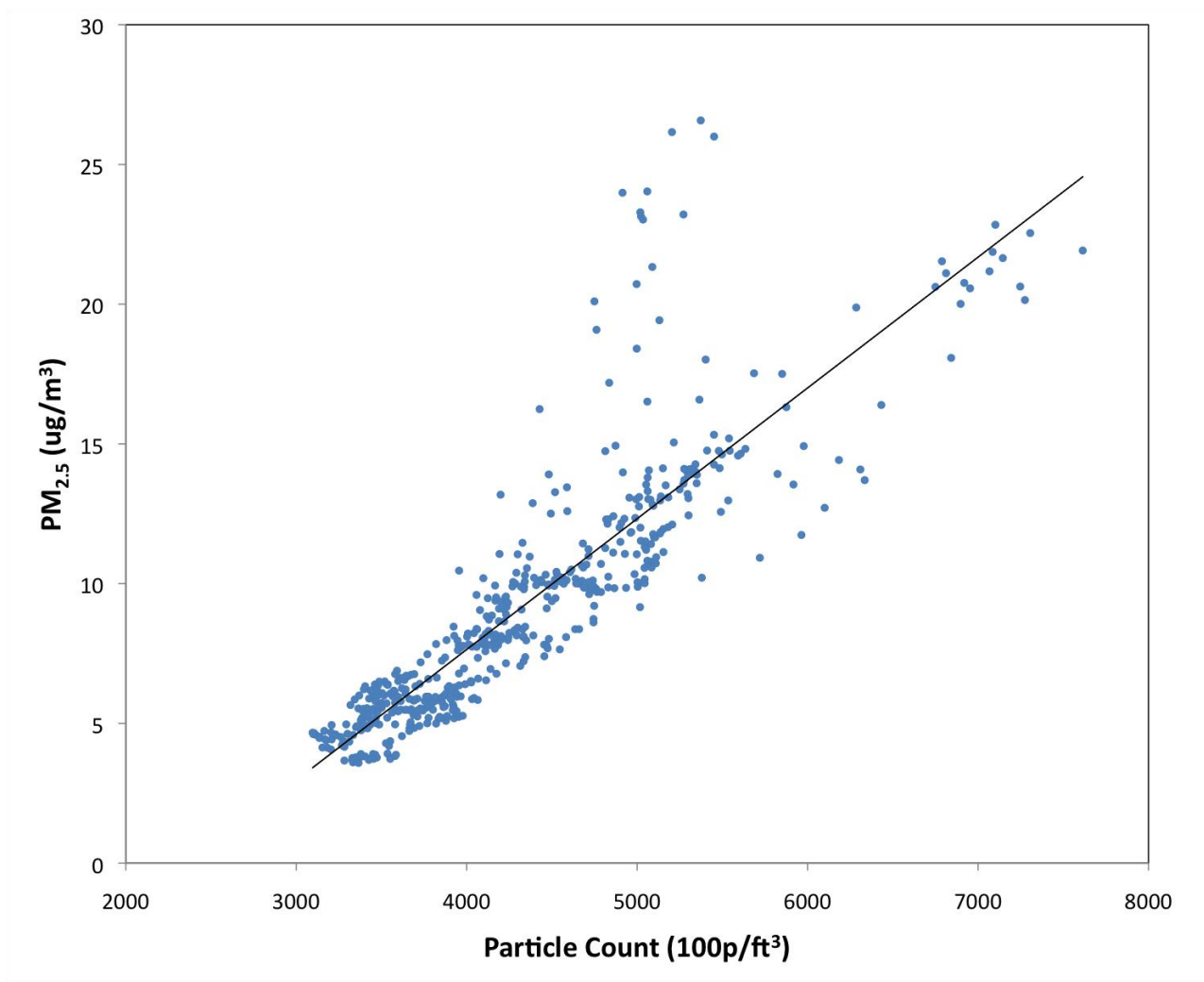

# Remember to Do Error Analysis

- ▶ Systematic error = mean value - true value
- ▶ Repeatability error = value with maximum error - mean value
- ▶ Accuracy = value with minimum error - mean value
- ▶ Hysteresis error = |measured value in increasing - measured value in decreasing|

For each true value, we can do error analysis

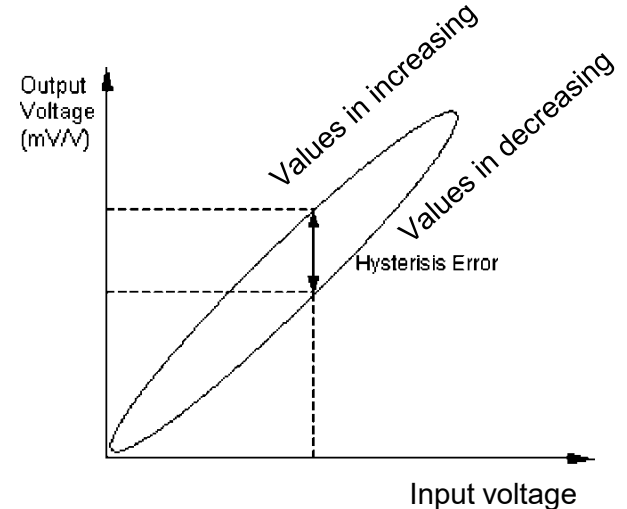
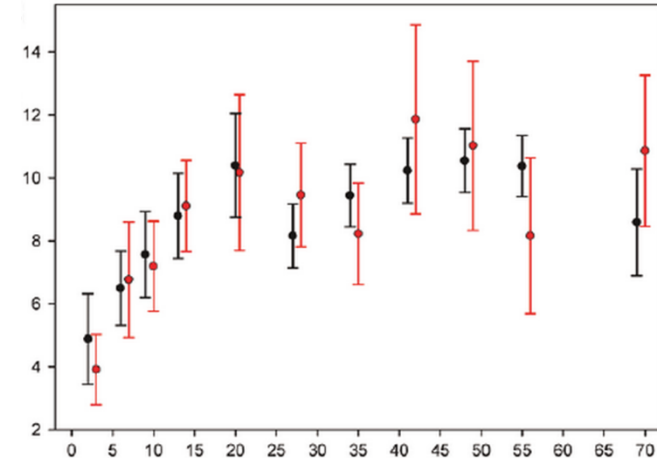

# How to Measure Gaseous Pollutants in Air?

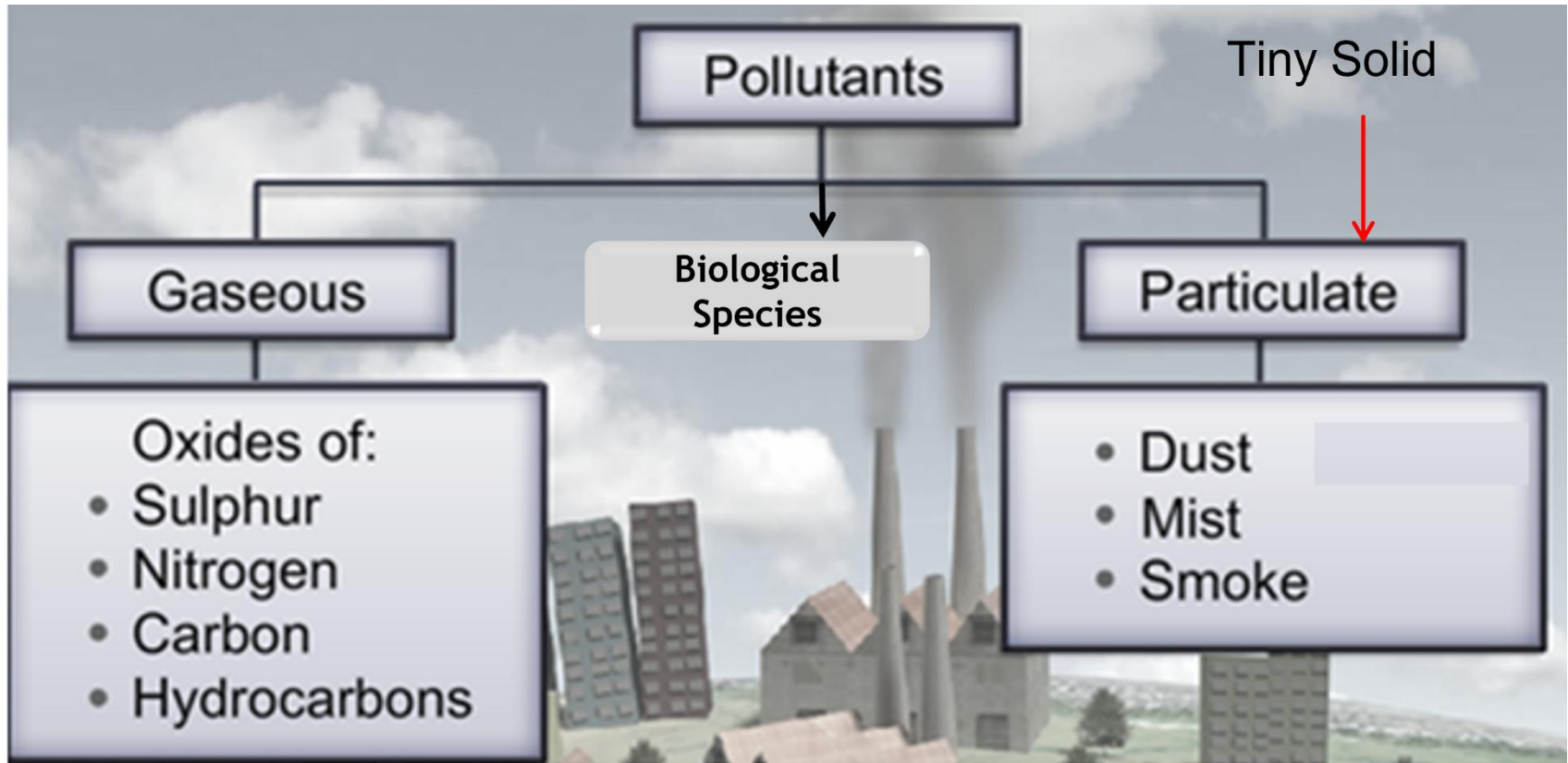

# General Principle 1 of Measurement

Energize Gas → Increase Vibration of Gas's Molecules → Emit Pressure Waves → Voltages

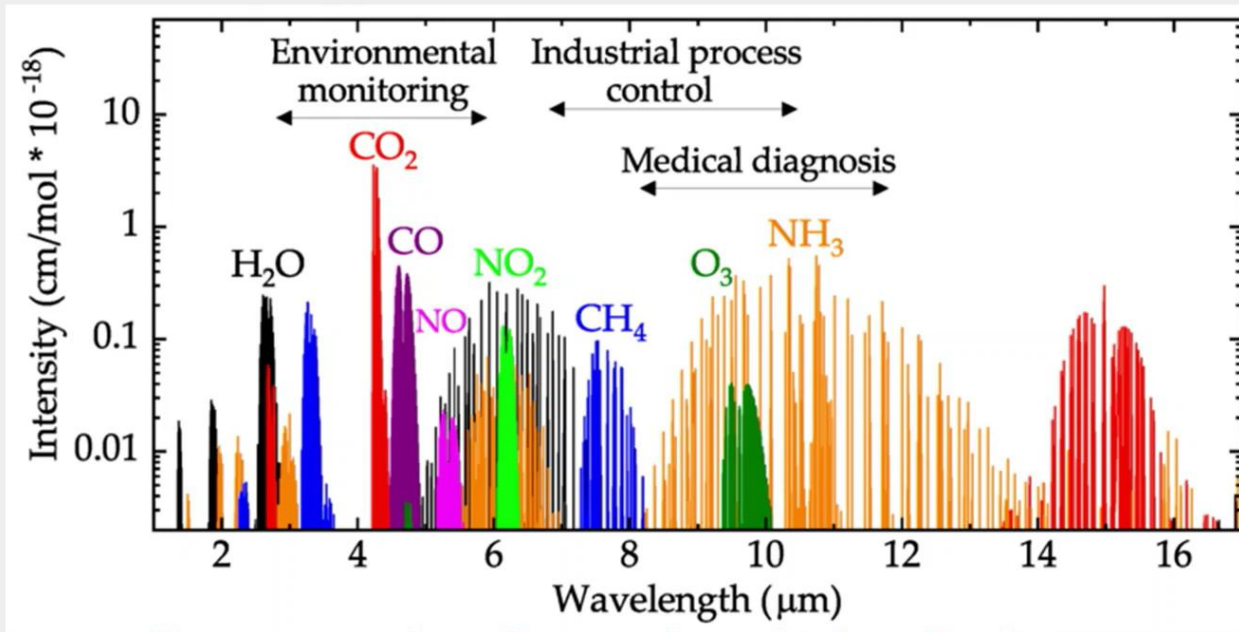

The sensor detects the length of the light in three ranges characteristic for carbon dioxide: CO<sub>2</sub> - 4.26 μm, 2.7 μm, about 13 μm

## Example of Design ...

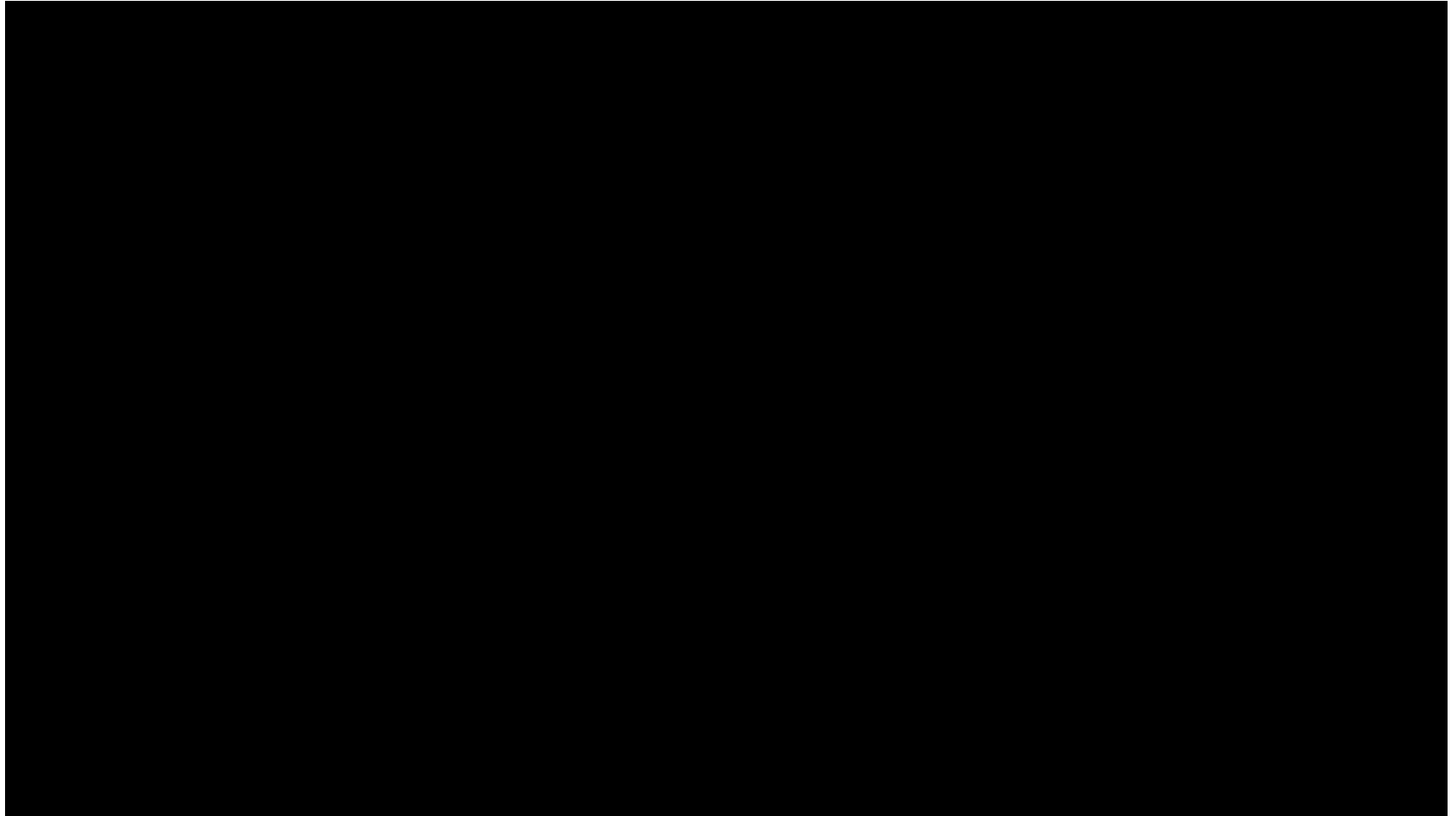

# General Principle 2 of Measurement

Energize Gas → Absorption of IR Lights → Thermal Energy Decrease → Voltages

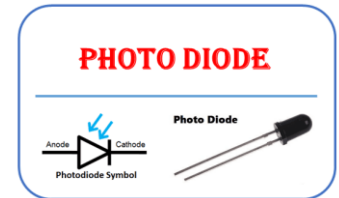
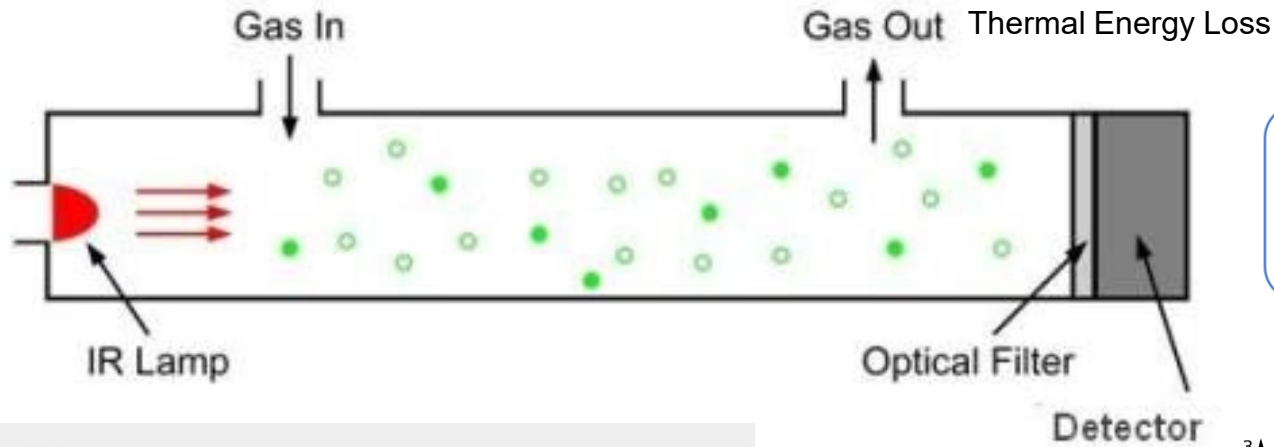

Pyroelectric Materials

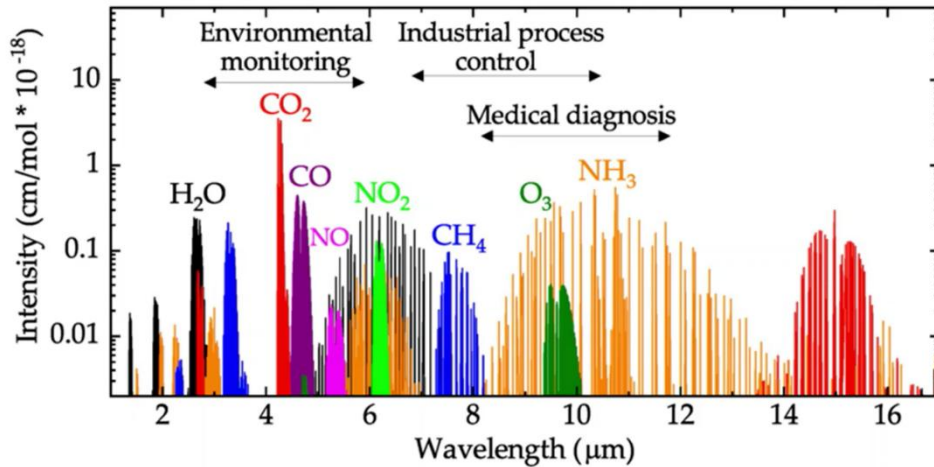
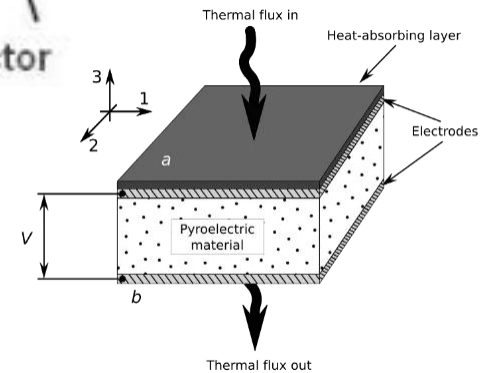

The pyroelectric effect is the ability of certain materials to generate a temporary voltage when heated or cooled.

# Example of Design ...

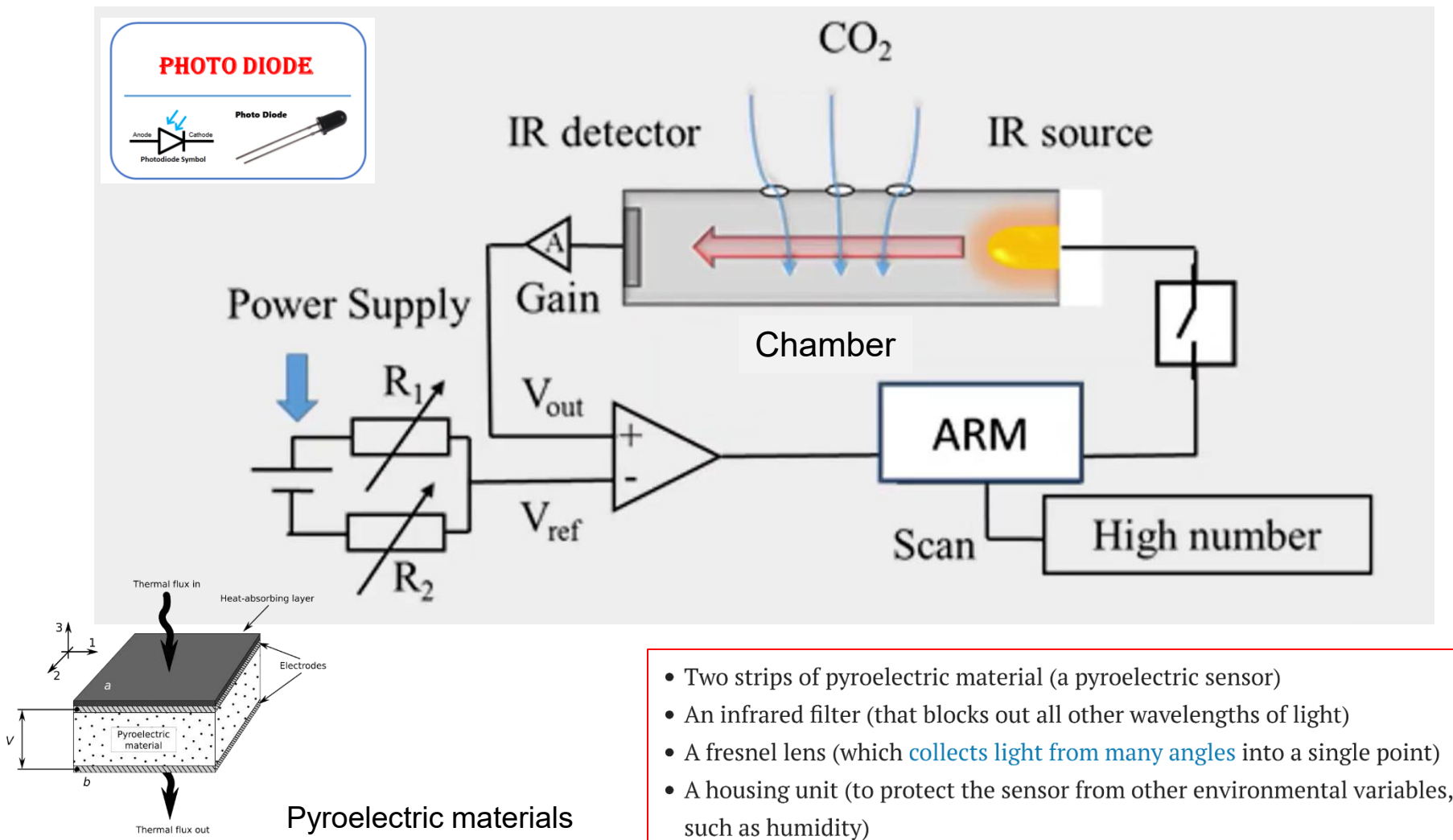

- Two strips of pyroelectric material (a pyroelectric sensor)
- An infrared filter (that blocks out all other wavelengths of light)
- A fresnel lens (which collects light from many angles into a single point)
- A housing unit (to protect the sensor from other environmental variables, such as humidity)

# More Example of Design ...

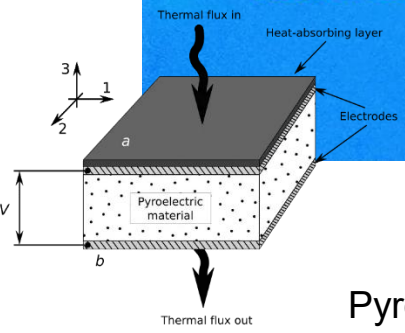
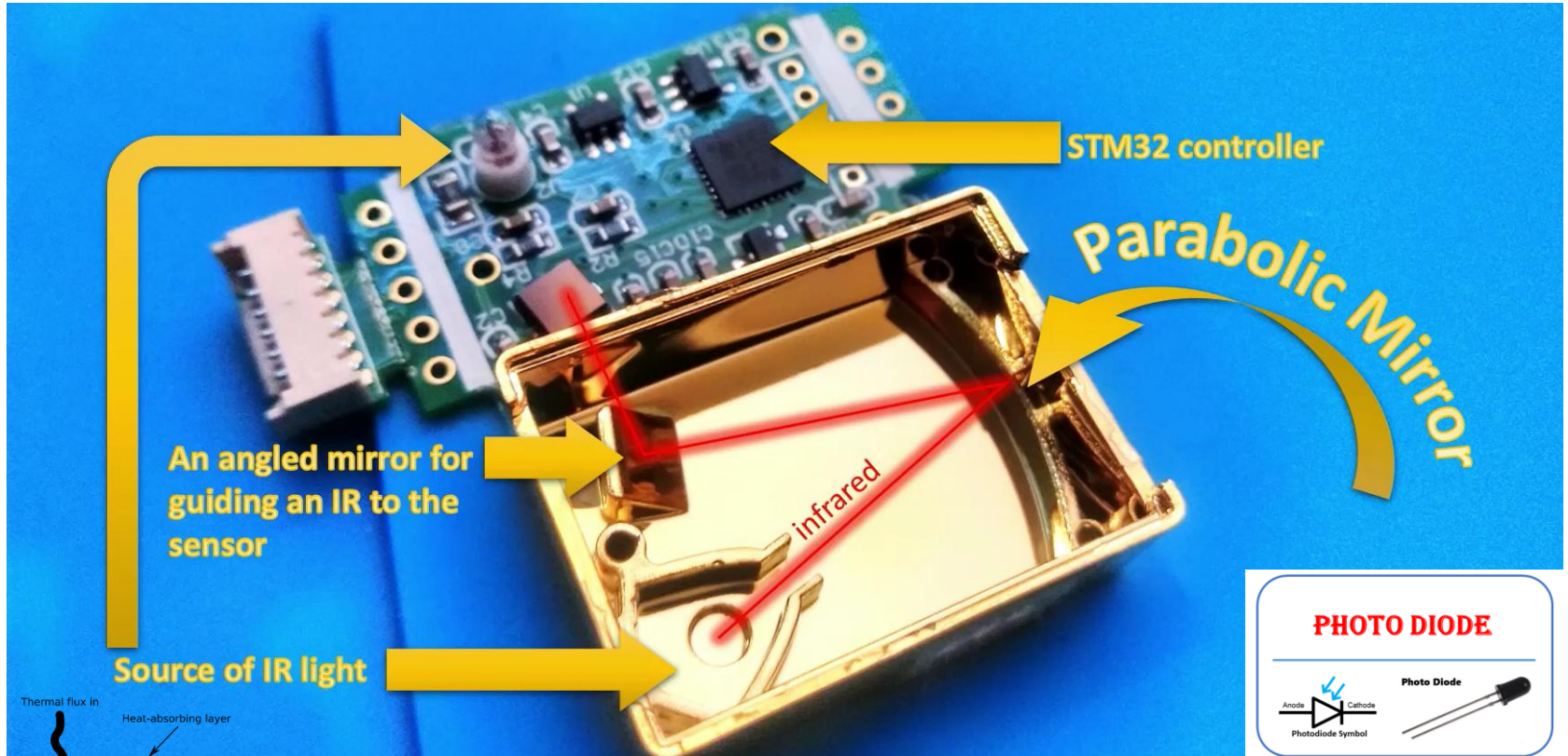

- Two strips of pyroelectric material (a pyroelectric sensor)
- An infrared filter (that blocks out all other wavelengths of light)
- A fresnel lens (which collects light from many angles into a single point)
- A housing unit (to protect the sensor from other environmental variables, such as humidity)

# Summary

- ▶ Concept of Active Sensing
- ▶ Understanding of Air Pollutants
- ▶ Parameter(s) of Dust in Air
- ▶ Measurement of Dust in Air

Carbon Monoxide  
Carbon Dioxide  
Nitrogen Oxide  
Sulphur Dioxide  
Volatile Organic Compounds  
**Particulate Matters**

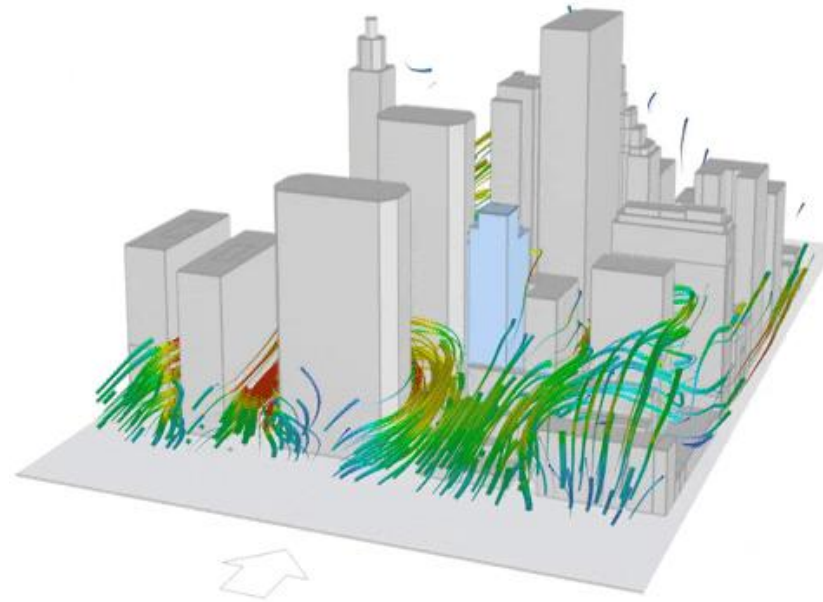
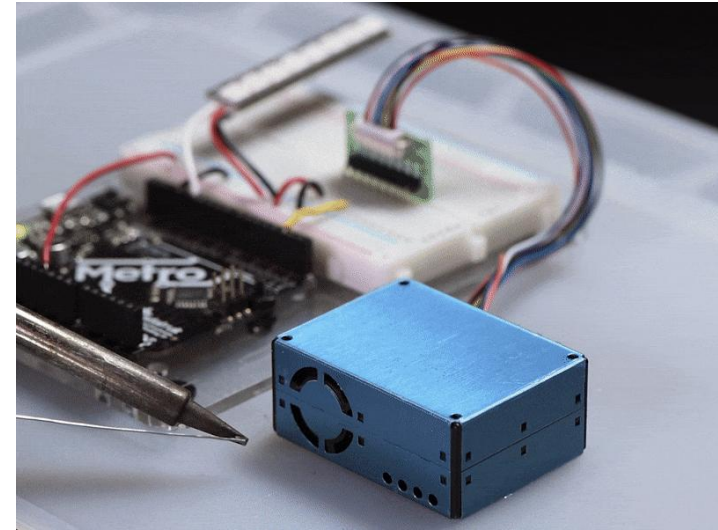

# Summary of Module 4

- ▶ Lecture 1:
  - ▶ Measurement of Pressure
- ▶ Lecture 2:
  - ▶ Measurement of Temperature
- ▶ Lecture 3:
  - ▶ Measurement of Humidity
- ▶ Lecture 4:
  - ▶ Measurement of Vibration
- ▶ Lecture 5:
  - ▶ Measurement of Air Quality

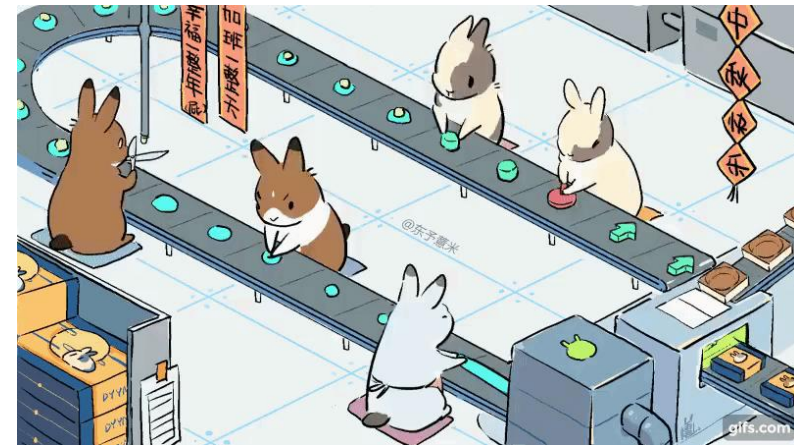



**NANYANG**  
**TECHNOLOGICAL**  
**UNIVERSITY**

**School of Mechanical & Aerospace Engineering**

Design, Machine, Control, Intelligence

“Ask not what your country can do for you – ask what you can do for your country,” - John F. Kennedy

“Do not think that you are needy – think that you are needed in the world”, - Manis Friedman

“Study will make you knowledgeable, resourceful, and hence more needed”, - Xie Ming

**Thank You for Listening!**